



Gas and Flame Detection

# Operation and Maintenance Manual

---

*GASMAX CS Wireless Gas Monitor*

---

GDS Corp.

1245 Butler Road • League City, TX 77573

409-927-2980 • 409-927-4180 (Fax) • [www.gdscorp.com](http://www.gdscorp.com)

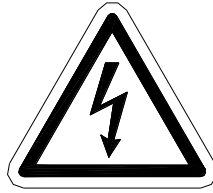

**CAUTION: FOR SAFETY REASONS THIS EQUIPMENT MUST BE OPERATED AND SERVICED BY QUALIFIED PERSONNEL ONLY. READ AND UNDERSTAND INSTRUCTION MANUAL COMPLETELY BEFORE OPERATING OR SERVICING.**

**ATTENTION: POUR DES RAISONS DE SÉCURITÉ, CET ÉQUIPEMENT DOIT ÊTRE UTILISÉ, ENTRETENU ET RÉPARÉ UNIQUEMENT PAR UN PERSONNEL QUALIFIÉ. ÉTUDIER LE MANUE D'INSTRUCTIONS EN ENTIER AVANT D'UTILISER, D'ENTRETENIR OU DE RÉPARER L'ÉQUIPEMENT.**

REVISION HISTORY

Revision 1.0    8//22/21    Initial Release

## CONTENTS

|          |                                |           |
|----------|--------------------------------|-----------|
| <b>1</b> | <b>SAFETY INFORMATION</b>      | <b>6</b>  |
| <b>2</b> | <b>OVERVIEW</b>                | <b>7</b>  |
| <b>3</b> | <b>INSTALLATION</b>            | <b>8</b>  |
| <b>4</b> | <b>PROGRAMMING &amp; SETUP</b> | <b>11</b> |
| <b>5</b> | <b>CALIBRATION</b>             | <b>15</b> |
| <b>6</b> | <b>MAINTENANCE</b>             | <b>18</b> |
| <b>7</b> | <b>TROUBLESHOOTING GUIDE</b>   | <b>20</b> |
| <b>8</b> | <b>SPECIFICATIONS</b>          | <b>21</b> |
| <b>9</b> | <b>DRAWINGS AND DIMENSIONS</b> | <b>22</b> |

## TABLE OF FIGURES

|  |    |
|--|----|
| FIGURE 3-1: GASMAX CS MECHANICAL ASSEMBLY .....  | 10 |
| FIGURE 3-2: GASMAX CS ELECTRONICS ASSEMBLY ..... | 10 |
| FIGURE 4-1: GASMAX CS USER INTERFACE.....        | 11 |
| FIGURE 9-1: GASMAX CS DIMENSIONS .....           | 22 |

# 1 SAFETY INFORMATION

## Important – Read Before Installation

Users should have a detailed understanding of GASMAX CS operating and maintenance instructions. Use the GASMAX CS only as specified in this manual or detection of gases and the resulting protection provided may be impaired. Read the following WARNINGS prior to use.

### WARNINGS

- The GASMAX CS must be installed, operated, and maintained in accordance with information contained herein. Installation in any hazardous area must comply with all applicable restrictions, requirements, and guidelines for said hazardous areas. It is the end user customer's final decision to ensure that the GASMAX CS is suitable for the intended use.
- The GASMAX CS is designed and constructed to measure the level of certain gases in ambient air. Accuracy in atmospheres containing steam or inert gases cannot be guaranteed.
- Do not paint transmitter or sensor assembly.
- Do not operate the GASMAX CS if its enclosure is damaged or cracked or has missing components. Make sure the cover, internal PCB's and field wiring are securely in place before applying power.
- Do not expose the GASMAX CS to electrical shock or continuous severe mechanical shock. Protect the GASMAX CS from dripping liquids and high-power sprays.
- Periodically test for correct end-to-end operation of the system's alarm events.

### WARRANTY

GDS Corp products carry a 2-year limited repair or replacement warranty on electronics and workmanship and one year warranty on sensors. GDS Corp. reserves the right to void warranty claims based on evidence of misuse, abuse, or misapplication. Warranty period starts on date of shipment.

### IF YOU HAVE QUESTIONS

GDS Corp  
1245 Butler Road, League City, Texas 77573  
409-927-2980 (Office), 409-927-4180 (Fax)  
[info@gdscorp.com](mailto:info@gdscorp.com)  
[www.gdscorp.com](http://www.gdscorp.com)

## 2 OVERVIEW

The GDS Corp GASMAX CS Non-Explosion-Proof Ambient Air Toxic Gas Detector is designed to detect a wide range of toxic gases in many environments. The GASMAX CS features non-intrusive magnetic switches that allow for complete system configuration, regular calibration, and product maintenance to be performed in the field, without opening the enclosure and breaking the seal of the enclosure.

The GASMAX CS continuously monitors the gas level of the surrounding environment and reports once every minute, the reporting rate will increase to once every five seconds when the detected gas is above the Background Gas set-point. This set-point is adjustable to account for sites that may have a constant low level of gas always present allowing the OI-6900 to maintain a long battery life. When the gas level drops below the set-point the reporting rate will return to once every minute. The GASMAX CS display screen will always show the present concentration of gas being detected by the sensor assembly. More information about the Background Gas Set-point is found later in this manual.

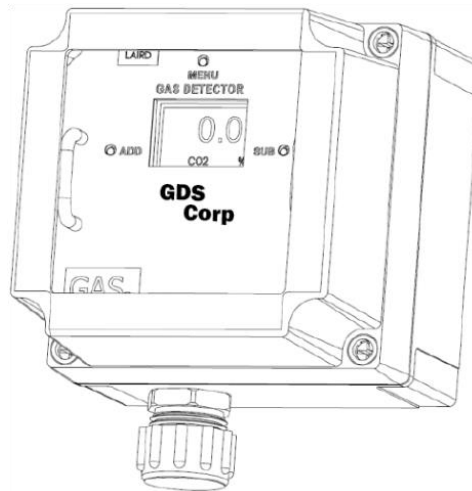

This document is an operation manual containing diagrams and step-by-step instructions for the proper and safe installation, start-up, configuration and settings, normal operation, and product maintenance of the GASMAX CS.

In this manual, the instructions reference the use of push-buttons, located on the front panel of the device. In certain environments, the activation of the non-intrusive magnetic switches, using a magnetic wand, will replace the directive of the button-press actions. **To apply the magnetic wand, hold the tool to the side of the device enclosure adjacent to the push-button that you wish to activate.** When the magnetic switch is toggled, an on-screen indicator will appear on the display screen, signifying that a connection was made.

Should a question arise during the use of the product, this document will serve as a first reference for the end-user. For inquiries beyond the information and instructions provided within this manual, contact a GDS Corp sales representative of this product for assistance.

## 3 INSTALLATION

### SELECTING A LOCATION

Factors such as prevailing winds, target gas density, potential leak sources, air movement machinery and similar environmental variables are important when selecting a location for the GASMAX CS gas monitor or gas sensor. Even though the GASMAX CS is designed for rugged service, sensors and electronics should be protected from environmental damage due to water, snow, shock, vibration, and dirt. In addition, the sensor and / or display should be located such that regular maintenance and periodic sensor replacement can be readily accomplished. While there are no industry standards for gas detector placement, professional tools exist that can simulate leaks or spills and provide excellent guidance for locating gas detectors throughout a facility.

### MOUNTING THE ENCLOSURE

The GASMAX CS includes four non-metallic mounting feet that can be used to mount the enclosure against a flat surface as shown.

When determining the final mounting location, please consider the following guidelines:

- The GASMAX CS should be placed more than 10 feet away from any wireless controller to ensure reliable communications
- Do not mount the GASMAX CS on a bulkhead, beam or wall that is subject to continuous vibration.
- Mounting the GASMAX CS on a large metallic surface will have a detrimental effect on wireless transmission range.
- The GASMAX CS should always be placed such that the sensor and rain guard are pointing downward.
- Avoid installing the unit in a location where airborne particles could cover or coat the sensor head.
- The GASMAX CS should be placed in an area that will produce the highest gas concentration. Enclosed corners and stopping points of moving devices are two areas susceptible to a buildup of toxic gas.
- To provide an accurate representative sample of a room, care should be taken to avoid locating the GASMAX CS near a room entrance, fresh air intake vent, or vehicle/generator exhaust point.
- The unit should be placed as close as physically possible to the source of the potential toxic gas leak.
- In consideration of any possible ignition points, the GASMAX CS should be placed between the potential leak source and ignition point.
- Consider placing the unit in a seldom used area, such as a warehouse, storage area, or other unfrequented location.
- Consider accessibility for regular calibration and other required maintenance.
- When monitoring a ventilated gas cylinder storage area, the unit should be placed near the air return vent.

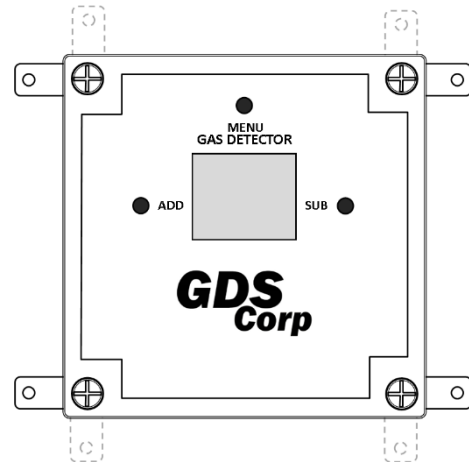

- When monitoring an outdoor or open-air area for gas that may be drawn into a building, the GASMAX CS should be placed near the air intake of the HVAC system for the building.
- When monitoring for the potential presence of multiple toxic gas types, the GASMAX CS should be calibrated for the least cross-sensitive toxic gas.

**NOTE: THE GASMAX CS IS NOT DESIGNED FOR USE IN HAZARDOUS AREAS**

**NOTE:** These guidelines are **ONLY** intended as a general directive for the placement of the GASMAX CS. This information should **NOT** serve as a complete list when considering all potential parameters for the proper location of the unit. It is **STRONGLY** advised that a third party Certified Industrial Hygienist, or other Certified Safety Professional, conduct a site survey and annotate the location and quantity of detection devices that should be installed for **EVERY** installation of **EVERY** site.

### **CONNECTING THE BATTERIES**

To prepare the GASMAX CS for installation, you must first open the device, exposing the control board and its components to connect the batteries.

1. Remove the enclosure lid, unscrewing the captive screws from the device enclosure base. Set aside.
2. Gripping the front panel handles, lift the electronics assembly out of the enclosure and rest it against the rim of the enclosure opening.
3. Plug the battery on the bottom of the radio board to the closer of the two battery plugs.
4. Plug the battery on the top of the radio board to the other battery plug.
5. Reinstall the electronics assembly by inserting the mounting posts into their respective receivers. Using the two front panel handles, gently push the display into place.
6. Verify that the sealing ring is properly installed.
7. Reinstall the enclosure lid using the captive screws. **DO NOT OVERTIGHTEN**
8. After battery power is applied, the GASMAX CS will enter the OFF mode.

### **SYSTEM START-UP**

Once the enclosure is properly closed you may turn the unit ON and begin its 3½-minute warmup period. During warmup, the display will show a countdown of the time remaining until the system start-up is complete. The GDS Corp logo and the unit information will also flash on the display screen during start-up.

After the mandatory 3 ½ minute warmup period, the GASMAX CS will be fully operational.

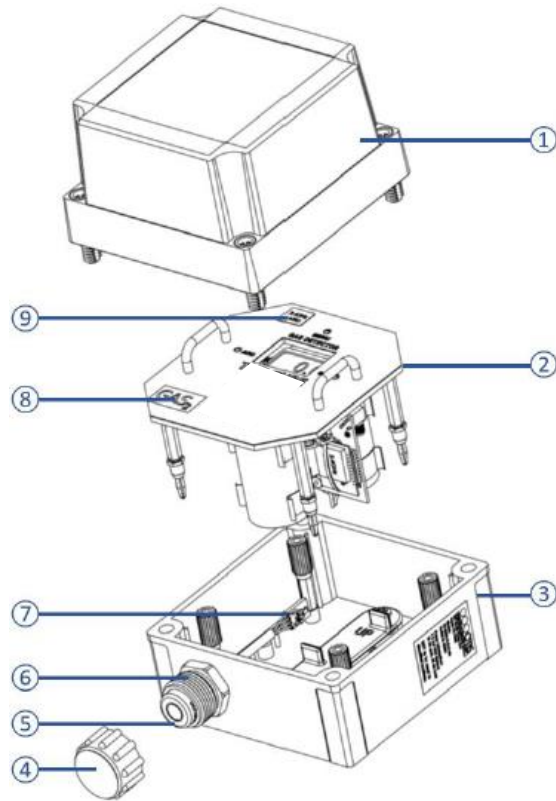

**Figure 3-1: GASMAX CS Mechanical Assembly**

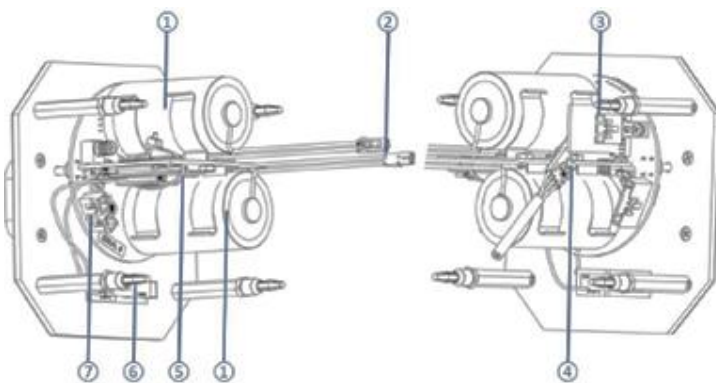

- 1. Batteries
- 2. Battery plugs
- 3. Sensor housing connector
- 4. Sensor housing plug
- 5. Radio module
- 6. Internal flexible antenna
- 7. Battery plug connectors

**Figure 3-2: GASMAX CS Electronics Assembly**

## 4 PROGRAMMING & SETUP

### USER INTERFACE

Once the batteries are installed, press the ADD button once to power-up the unit and start the 3 ½ minute warmup period. To turn the unit OFF, press and HOLD the SUB button for approximately six (6) seconds.

To enter the **Product Settings and Configuration Menu**, press and HOLD the MENU button for approximately six (6) seconds.

For information on Null (zero) and Cal (span) procedures, see Section 5, CALIBRATION.

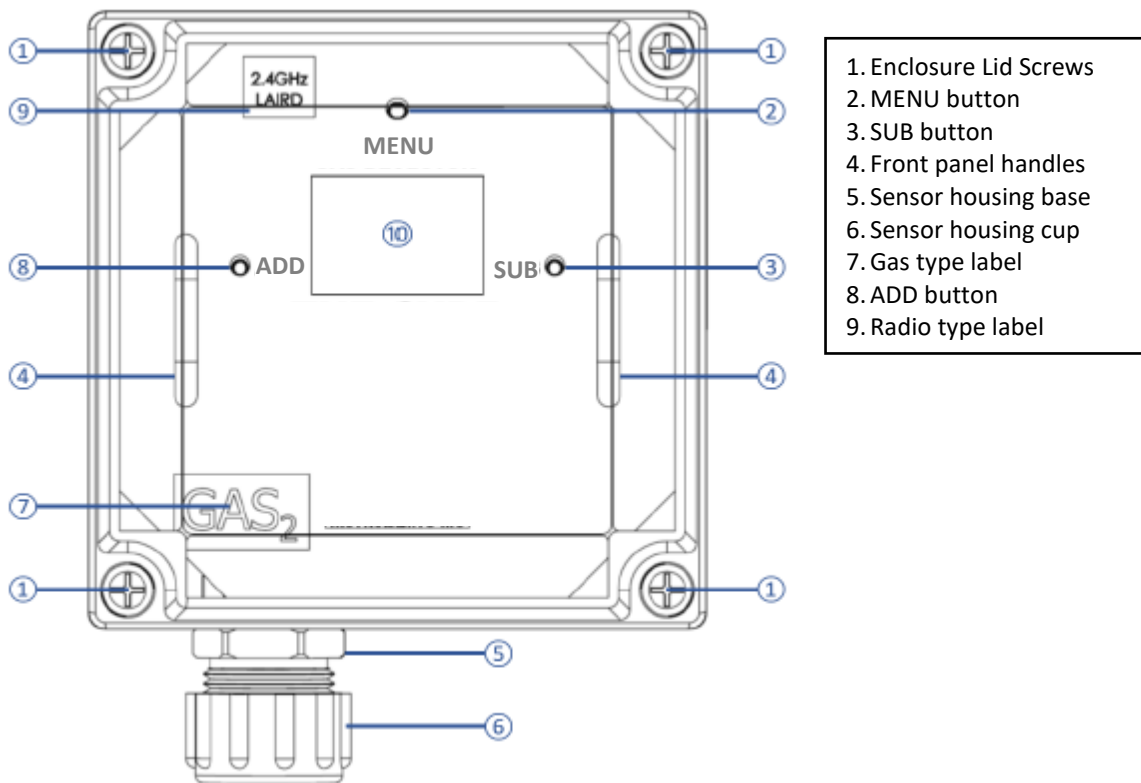

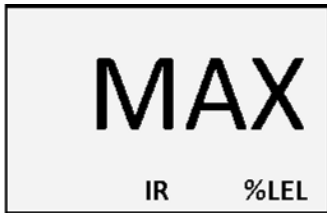
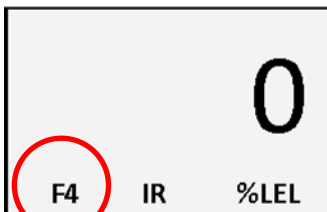

Figure 4-1: GASMAX CS User Interface

**NORMAL OPERATION**

During normal operation, the display shows the current measured and calibrated gas value, the gas engineering units (“ppm” or “%LEL”) and the type of sensor attached.





|  |  |
|--|--|
| <p>During normal operating mode, the GASMAX CS continuously samples the air and updates the measured concentration of the target gas on the display screen. The display, when in normal operation, displays the measured gas concentration (“1”), the gas unit of measure (“%LEL”) and type of sensor (“IR”)</p> |   |
| <p>In the event the detected level of gas meets or exceeds the maximum range of the device (100% LEL), the unit will display “MAX” in place of the measured gas concentration on the display.</p>  |   |
| <p>In the event of a device failure, the unit will alternate between the normal operating screen and a fault screen on the display, in 5 second intervals, until the fault has been cleared, or is corrected. The fault code, located in the bottom-left corner of the display, appears on both screens.</p>     |  |

**PRODUCT SETTINGS AND CONFIGURATION MENU**

The PRODUCT SETTINGS AND CONFIGURATION MENU allows the end-user to tailor the device settings to meet their required specifications and/or site conditions.

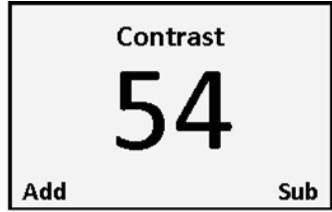
|  |   |
|--|---|
| <p><b>To Enter the PRODUCT SETTINGS AND CONFIGURATION MENU press and HOLD both the MENU button for 6 seconds.</b></p>  |   |
| <p>1. This function tests relays in the wireless system controller by transmitting simulated detected gas values. Press ADD increase the transmitted value. Press SUB to return the transmitted value to the current value. Press MENU to advance to next setting</p> <p><b>NOTE: BE CAREFUL WHEN SIMULATING ALARM CONDITIONS!</b></p> |  |

|  |  |
|--|--|
| <p>2. Press ADD or SUB until the Network ID matches the value being used at the System Controller<br/>Press MENU to advance to next setting</p>  | <div style="border: 1px solid black; padding: 5px; text-align: center;"> <p><b>Network ID</b></p> <p style="font-size: 2em;"><b>5</b></p> <p><b>Add</b> <span style="float: right;"><b>Sub</b></span></p> </div> |
| <p>3. The system information screen allows the user to view details on connection status, battery voltage, null setting and more<br/>Press MENU to advance to next setting</p>   | <div style="border: 1px solid black; padding: 5px;"> <p style="text-align: center;"><b>SYSTEM</b></p> <p>Rad: Link<br/>Scale: 100<br/>Battery: 3.50v<br/>Null: 0.00%V<br/>Sens: 0.00%V</p> </div>                |
| <p>4. The null / calibration information screen allows the user to view details on days since last null and days since last calibration<br/>Press MENU to advance to next setting</p>  | <div style="border: 1px solid black; padding: 5px;"> <p style="text-align: center;"><b>LAST SETUP TIMES</b></p> <p>Null: 1 Day(s)<br/>Cal: 1 Day(s)<br/>Cal #: 0.00</p> </div>                                   |
| <p>5. The unit information screen allows the user to view the number of times the radio has transmitted data without receiving a response, date of manufacture and serial number<br/>Press MENU to advance to next setting</p>   | <div style="border: 1px solid black; padding: 5px;"> <p style="text-align: center;"><b>UNIT INFO</b></p> <p>Radio Miss: 0<br/>Date: 04/02/2020<br/>Serial #: C98742</p> </div>                                   |
| <p>6. The background setting is the gas reading at which the data transfer rate changes from once per minute to once every five seconds. This setting is adjustable so that a consistent low level of gas will not run the battery down Press ADD or SUB to increase or decrease the setting<br/>Press MENU to advance to next setting</p>   | <div style="border: 1px solid black; padding: 5px; text-align: center;"> <p><b>Background</b></p> <p style="font-size: 2em;"><b>4</b></p> <p><b>Add</b> <span style="float: right;"><b>Sub</b></span></p> </div> |
| <p>7. The calibration method selection allows you to choose how you calibrate the sensor element. Manual calibration is the default method for all gas types. The CO2 &amp; DCO2 gas types can only be auto calibrated; therefore, this screen will not appear. Use the ADD button to select manual calibration and the SUB button to select auto-calibration.<br/>Press MENU to advance to next setting</p> | <div style="border: 1px solid black; padding: 5px; text-align: center;"> <p><b>Cal Method</b></p> <p><b>Current: Manual</b></p> <p><b>MAN</b> <span style="float: right;"><b>AUTO</b></span></p> </div>          |

|   |   |
|---|---|
| <p>8. Press ADD or SUB to adjust the screen contrast setting. The adjust is from 1 to 64<br/>Press MENU to advance to the next setting</p>  |    |
| <p>9. Press the ADD button to select "Yes" to return the device to its factory default settings and to advance to the return to factory default settings confirmation screen. If you do not wish to return the device to its factory default settings, press the SUB button to select "No" to <b>leave the product settings and configuration menu</b> and to return the device to normal operating mode.</p>   |    |
| <p>10. Press the ADD button to select "Yes" to confirm you want to reset the device to factory default settings and return to normal operating mode. If you do not wish to continue, press the SUB button to select "No" to <b>leave the product settings and configuration menu</b> and to return the device to normal operating mode.</p>   |    |
| <p>11. Resetting the null and calibration settings of the sensor element will allow the currently stored values to be reset without having to reconfigure other operational settings</p> <p>Press the ADD button to select "Yes" to reset the Null and Calibration values and to advance to the Reset Null &amp; Cal Only confirmation screen. If you do not wish to reset the values, press the SUB button to select "No" to <b>leave the product settings and configuration menu</b> and to return the device to normal operating mode.</p> |  |
| <p>12. Press the ADD button to select "Yes" to confirm you want to reset the null and cal settings and return to normal operating mode. If you do not wish to continue, press the SUB button to select "No" to <b>leave the product settings and configuration menu</b> and to return the device to normal operating mode.</p>  |  |

## 5 CALIBRATION

### CALIBRATION

Calibration is the process of evaluating and adjusting the precision and accuracy of measurement equipment. Although GDS Corp tests and calibrates every device at the factory, for best accuracy, the GASMAX CS SHOULD be initially calibrated in the environment where it is installed.

It is imperative that calibration occur as part of the installation process, and then every thirty (30) to sixty (60) days thereafter. Days since last calibration should NEVER exceed ninety (90) days. GDS Corp recommends that you calibrate your device regularly to ensure proper functionality and a safe work environment.

Each calibration involved a null (zero) and cal (span) process. GDS Corp recommends that every calibration include the null (zero) process.

### CALIBRATION SEQUENCE

The CALIBRATION SEQUENCE allows the end-user to null (zero) and cal (span) the GASMAX CS.

**To Enter the CALIBRATION MENU press and release the MENU button**

| SENSOR NULL (zero)   |   |
|--|---|
| <p>1. The first step of calibration is nulling the sensor This nulling process <b>MUST</b> be performed in known clean air, with no contaminants or hazardous gasses present. If air quality cannot be guaranteed, a bottle of zero air will be required to properly null the sensor. Press ADD to move to the confirmation screen.</p>  | <div style="border: 1px solid black; padding: 10px; width: fit-content; margin: auto;"> <p><b>Null<br/>Press<br/>ADD<br/>to auto null</b></p> </div>              |
| <p>2. If the sensor is not in clean air, press the SUB button to select "No" to discontinue the null process and to return to the previous screen.<br/><i><b>If necessary, attach a calibration adapter to the sensor and connect a "zero air" gas cylinder and regulator to the calibration adapter. Turn on the regulator and allow zero air to flow.</b></i> Press the ADD button to select "Yes" to confirm that the sensor is in clean air and to begin nulling the sensor.</p> | <div style="border: 1px solid black; padding: 10px; width: fit-content; margin: auto;"> <p><b>Null<br/>Is Sensor in<br/>Clean Air?<br/>Yes      No</b></p> </div> |

|   |   |
|---|---|
| <p>3. The unit will automatically begin the 12-second null process. During null, the display will show a countdown of the time remaining until the process is complete.</p>   | <div style="border: 1px solid black; padding: 10px; text-align: center;"> <p>Null<br/>Auto Nulling<br/>...<br/>12</p> </div>                  |
| <p>4. When the null process is complete, press the MENU button to advance to the next screen. <b>Turn off and remove the cylinder of zero air if used.</b></p>  | <div style="border: 1px solid black; padding: 10px; text-align: center;"> <p>Null<br/>Auto NULL<br/>Complete</p> </div>                       |
| <p style="text-align: center;"><b>SENSOR CALIBRATION (Span)</b></p> <p>If MANUAL CALIBRATION has been selected, the calibration sequence will proceed to Steps 5 &amp; 6 and then to radio address setup.</p> <p>If AUTOMATIC CALIBRATION has been selected the sequence will proceed to Steps 7-12 and then to radio address setup.</p> <p style="text-align: center;">(See Step 7 in the Product Settings and Configuration Menu)</p> |   |
| <p style="text-align: center;"><b>MANUAL CALIBRATION</b></p>  |   |
| <p>5. <b>Attach a calibration adapter to the sensor and connect the calibration gas cylinder to the calibration adapter. Turn on the gas regulator and verify that gas is flowing</b></p> <p>As gas continues to flow, the reading shown will increase.</p>   | <div style="border: 1px solid black; padding: 10px; text-align: center;"> <p>Calibration<br/>0.0<br/>Add                      Sub</p> </div>  |
| <p>6. When the reading stabilizes, after approximately 1 ½ to 2 minutes, use the ADD and SUB buttons to adjust the reading on the screen to match the applied calibration gas concentration.</p> <p>Press the MENU button to lock in the results of the calibration. <b>Turn off and remove the cylinder of zero air if used.</b></p>   | <div style="border: 1px solid black; padding: 10px; text-align: center;"> <p>Calibration<br/>50.0<br/>Add                      Sub</p> </div> |

| <b>AUTOMATIC CALIBRATION</b>   |  |
|--|--|
| <p>7. Press the ADD button to select "Yes" to begin the calibration process and to advance to the calibration confirmation screen. <b><i>Attach a calibration adapter to the sensor and connect the calibration gas cylinder to the calibration adapter. Do not flow gas at this time.</i></b></p> | <p><b>Calibration</b><br/>           Would you like to cal this unit?<br/>           Yes      No</p>         |
| <p>8. Press the ADD button to select "Yes" to confirm that you want to calibrate the sensor and to continue to the concentration setting screen or press the SUB button to select "No" to advance to the sensor radio address setting screen.</p>  | <p><b>Calibration</b><br/>           Are you sure you want to cal?<br/>           Yes      No</p>            |
| <p>9. Use the ADD and SUB buttons to adjust the value to match the calibration gas being used. Press the MENU button to save the gas concentration setting and to advance to the calibration start screen.</p>   | <p><b>Calibration</b><br/>           Set PPM Hit<br/>           Menu when done<br/>           Add 50 Sub</p> |
| <p><b>10. Turn on the calibration regulator and make sure gas is flowing into the calibration adapter</b> Press the MENU button to continue. Press the MENU button to start the automatic calibration process.</p>   | <p><b>Calibration</b><br/>           Apply gas then hit Menu button</p>                                      |
| <p>11. The GASMAX CS will automatically begin the 120-second calibration process. During calibration, the display will show a countdown of the time remaining until the process is complete.</p>   | <p><b>Calibration</b><br/>           It will be calcd at the end of timer<br/> <b>120</b></p>                |
| <p><b>12. When calibration is complete, turn off and remove the cylinder of calibration gas.</b></p>   | <p><b>Calibration</b><br/>           Unit is now calcd to 50 ppm<br/> <b>Reading: 50</b></p>                 |
| <p>13. Use the ADD and SUB buttons to increase and decrease the sensor radio address. Press the MENU button to exit the CALIBRATION SEQUENCE.</p>  | <p><b>Radio Ad:</b><br/> <b>1</b><br/>           Add                      Sub</p>                            |

## 6 MAINTENANCE

### SCHEDULED MAINTENANCE

GDS Corp recommends that our equipment be calibrated a MINIMUM of every 90 days, and STRONGLY advise that calibration be performed every 30 days. Without knowing the specific application, sensor assembly location, gas exposure, and other factors, GDS Corp recommends monthly calibrations – assuming no damage or potential damage has occurred to the sensor and that there has not been a power outage to the sensor assembly. If damage has occurred or the power supplied to the sensor has changed, a calibration should be completed immediately.

Scheduled maintenance **should include the null and calibration of the sensor and a relay test**. Consult the Sensor Calibration and Relay Test sections of this manual for further information and instructions on how to perform these procedures.

The sensor head **should be kept free of airborne particles, dirt, mud, spider webs, bugs and insects, and/or any other debris that could potentially cover or coat the sensor**. Keeping the sensor head clear of foreign articles will allow for proper operation of the device. A brief inspection during scheduled maintenance should suffice, but dependent upon the location and the environment in which the unit is installed, more frequent inspections may be warranted.

The sensor assembly may be adversely affected by the exposure to certain airborne substances. Loss of sensitivity or corrosion may be gradual if such materials are present in sufficient concentrations.

Other inhibiting substances include those that can coat the internal walls of the optical chamber (when using an infrared sensor) and reduce reflectivity. These include, but are not limited to, heavy oil deposits, dust/powder, water condensation, and salt formation.

Continuous and high concentrations of corrosive gases may also have a detrimental long-term effect on the product's service life. The presence of such substances in an area does not preclude the use of this device, but the likelihood of the shortened lifetime of the sensor element should be noted. Use of the sensor assembly in these environments may require more frequently scheduled maintenance to ensure safe and reliable system performance.

### SENSOR REPLACEMENT

The sensor elements used in the GASMAX CS detects gas in either % or PPM concentrations; this element must be fully functional for the system to operate correctly. GDS Corp recommends replacing the sensing element whenever a slow response to gas is observed during the normal calibration process. After replacing the sensor element, the device **MUST** then be nulled and calibrated for proper operation of the device.

| <b>Sensor Replacement</b> |   |
|---------------------------|---|
| 1                         | Press and HOLD the SUB button for approximately 8 seconds until "OFF" appears |
| 2                         | Unscrew the sensor housing cap and set aside.                                 |
| 3                         | Using your thumb and forefinger, gently unplug the sensor element             |
| 4                         | Plug in the new sensor element taking care to align the pins properly.        |
| 5                         | Replace the sensor housing cap  |
| 6                         | Press the ADD button to power-up the GASMAX CS                                |

### **BATTERY REPLACEMENT**

The GASMAX CS battery life will vary based on the sensor type and the presence of gas that will increase the radio transmission rate (and decrease this battery life) It is recommended that the batteries be replaced when the voltage reported is 3.2 volts or less. To determine the battery voltage, you can reference the Product Information section of this manual. When replacing the batteries, they SHOULD be replaced in pairs, and you should NEVER mix old and new batteries.

After replacing the batteries, it is STRONGLY suggested that the sensor assembly be nulled and calibrated for proper operation of the device.

| <b>Battery Replacement</b> |  |
|----------------------------|--|
| 1                          | Press and HOLD the SUB button for approximately 8 seconds until "OFF" appears  |
| 2                          | Remove the lid by loosening the four captive screws. Set the cover aside.  |
| 3                          | Grasp the two handles and gently pull the electronics assembly out of the enclosure. Carefully hang the electronics assembly on the side of the enclosure. |
| 4                          | Locate and disconnect the two battery plugs. Squeeze the locking tab to remove.  |
| 5                          | Remove the two old batteries. NOTE: ALWAYS REPLACE BATTERIES IN PAIRS  |
| 6                          | Gently slide the new batteries into the spring clips.  |
| 7                          | Reconnect the battery plugs.   |
| 8                          | Reassemble the electronics assembly and base and reinstall the cover   |
| 9                          | Press the ADD button to power-up the GASMAX CS   |

## 7 TROUBLESHOOTING GUIDE

### DEVICE APPEARS INOPERATIVE

- Batteries dead. Replace batteries.
- Electronics damaged. Replace electronics.

### FAULT SHOWING "F4"

- The control board has lost communications with the sensor element or sensor interface board. (Replace sensor interface board)

### FAULT SHOWING "F5"

- The unit did not null correctly due to the presence of background gas (Re-zero the unit in clean air)
- The unit did not null correctly due to a sensor error (Replace the sensor)
- The unit did not null correctly due to an analog sensor board error (Replace the sensor board)

### FAULT SHOWING "F6"

- The unit did not calibrate (span) correctly due to the absence of calibration gas (Check the expiration date of the gas or replace the gas)
- The unit did not calibrate (span) correctly due to a sensor error (Replace the sensor)
- The unit did not calibrate (span) correctly due to an analog sensor board error (Replace the sensor board)

### FAULT SHOWING "F14"

- Sensor assembly has lost communications with System Controller due to excessive range (Move sensor closer to System Controller or re-position antenna)
- Sensor assembly has lost communications with System Controller due to incorrect network ID (Check sensor ID)
- Sensor assembly has lost communications with System Controller due to failed radio (Replace radio module)

## 8 SPECIFICATIONS

|                        |  |
|------------------------|--|
| Power                  | 3.6 VDC 19Ah each, 38 Ah total Lithium-Thionyl (Li-SOCl <sub>2</sub> ) Battery   |
| Estimated Battery Life | Electrochemical Sensor - 2 Years Maximum<br>Photo Ionization Detector Sensor – 14 Days +<br>Dynament Lower Power IR – 2.5 - 3 Months |
| Temperature            | -20°C to +54°C (operating)   |
| Humidity               | 0-98% noncondensing  |
| Measurement            | Gas concentration depends on sensor selected   |
| Response Time          | Gas response depends on sensor selected  |
| Radio Option           | 900 MHz, 52 networks, 255 sensors per network<br>2.4 GHz, 78 networks, 255 sensors per network                                       |
| Antenna                | internal   |
| Display                | Transflective (sunlight-readable)<br>102x64 LCD Screen LED Back-Light  |
| Interface              | 3 Pushbuttons (MENU, ADD, SUB)<br>3 Magnetic Switches for Non-Intrusive Calibration  |
| Dimensions             | 6.4" T x 5.12" W x 4.98" D (Maximum w/ Attachments)<br>3.25 lbs  |
| Approvals              | For use in general purpose areas only  |
| Warranty               | Two years from date of purchase  |

## 9 DRAWINGS AND DIMENSIONS

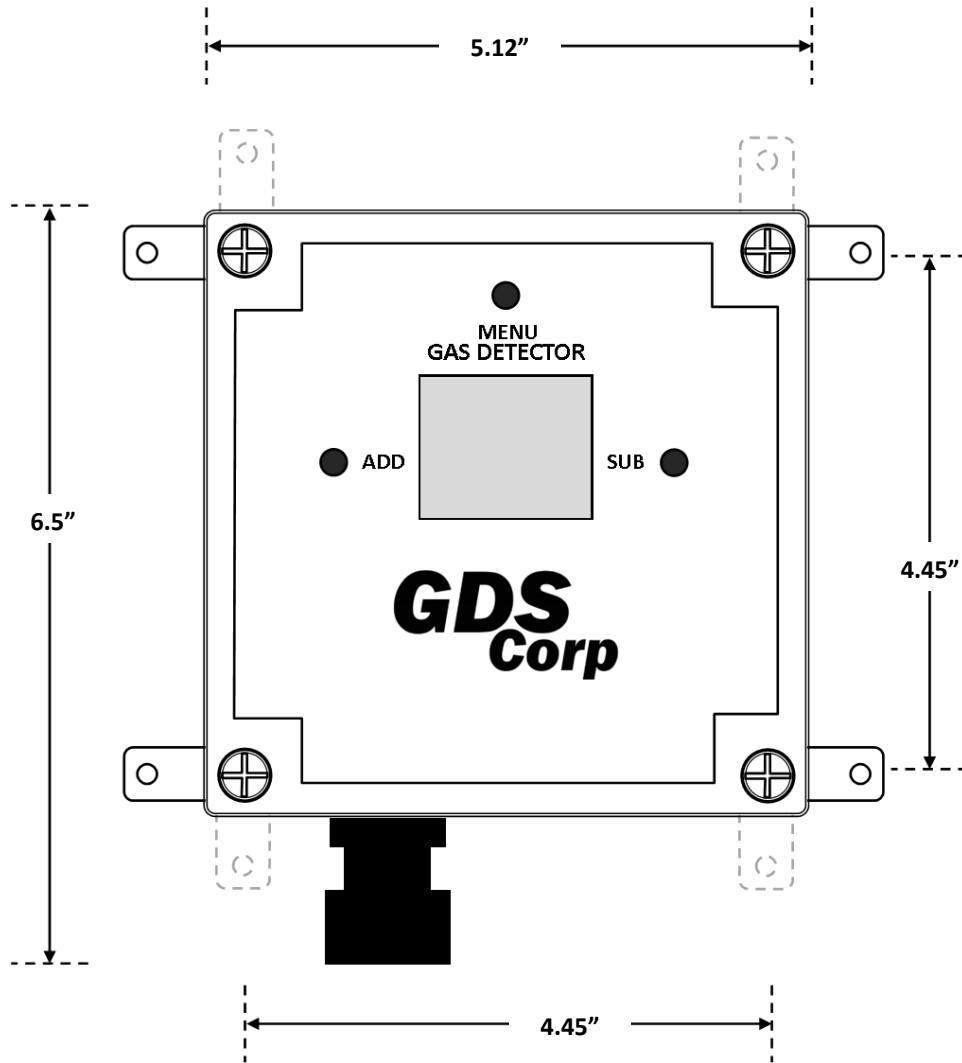

Figure 9-1: GASMAX CS Dimensions

