



Gas and Flame Detection

Operation and Maintenance Manual

GDS-49 Remote 4-20mA Sensor Transmitter for Toxic Gases

GDS Corp.
1245 Butler Road • League City, TX 77573
409-927-2980 • 409-927-4180 (Fax) • www.gdscorp.com

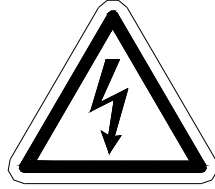

CAUTION: FOR SAFETY REASONS THIS EQUIPMENT MUST BE OPERATED AND SERVICED BY QUALIFIED PERSONNEL ONLY. READ AND UNDERSTAND INSTRUCTION MANUAL COMPLETELY BEFORE OPERATING OR SERVICING.

ATTENTION: POUR DES RAISONS DE SÉCURITÉ, CET ÉQUIPEMENT DOIT ÊTRE UTILISÉ, ENTRETENU ET RÉPARÉ UNIQUEMENT PAR UN PERSONNEL QUALIFIÉ. ÉTUDIER LE MANUE D'INSTRUCTIONS EN ENTIER AVANT D'UTILISER, D'ENTRETENIR OU DE RÉPARER L'ÉQUIPEMENT.

REVISION HISTORY

Revision 1.1 4/15/13 Initial Release

Copyright © 2013 GDS Corp. All Rights Reserved

P/N 1200-0850-01

CONTENTS

1	SAFETY INFORMATION	4
2	GENERAL INFORMATION	5
3	SPECIFICATIONS.....	6
4	INSTALLATION	9
	CHOOSING A LOCATION	9
	ELECTRICAL CONNECTIONS	10
5	CALIBRATION.....	12
	CALIBRATION OVERVIEW	12
	GENERALIZED CALIBRATION PROCEDURE	12
6	OPERATION AND MAINTENANCE	14
	SENSOR REPLACEMENT	14
7	SPARE PARTS.....	16
	GRAY ENCLOSURE	16
	YELLOW ENCLOSURE	16
	SENSOR HEAD ACCESSORIES	17
8	DRAWINGS AND DIMENSIONS	18

Table of Figures

Figure 3-1: Recommended Sensor Temperature Range.....	7
Figure 3-2: Recommended Sensor Warmup Times	7
Figure 3-3: Sensor Minimum and Maximum Ranges.....	8
Figure 4-1: GDS-49 Remote Sensor Transmitter.....	9
Figure 4-2: GDS-49 Wiring Connections (Gray Enclosure)	10
Figure 4-3: GDS-49 Wiring Connections (Yellow Enclosure).....	10
Figure 5-1: Applying Calibration Gas to GDS-49	13
Figure 6-1: Sensor Replacement.....	15
Figure 8-1: GDS-49 Yellow Housing	18
Figure 8-2: GDS-49 Gray Housing	19

1 SAFETY INFORMATION

Important – Read Before Installation

Users should have a detailed understanding of GDS-49 operating and maintenance instructions. Use the GDS-49 only as specified in this manual or detection of gases and the resulting protection provided may be impaired. Read the following WARNINGS prior to use.

WARNINGS

- The GDS-49 sensor transmitter described in this manual must be installed, operated and maintained in accordance with information contained herein. Installation in any hazardous area must comply with all applicable restrictions, requirements and guidelines for said hazardous areas. It is the end user customer's final decision to ensure that the GDS-49 is suitable for the intended use.
- The GDS-49 is designed and constructed to measure the level of certain gases in ambient air. Accuracy in atmospheres containing steam or inert gases cannot be guaranteed.
- Always mount the sensor head vertically with the sensor head facing down.
- Do not paint sensor assembly.
- Do not operate the GDS-49 if its enclosure is damaged or cracked or has missing components. Make sure the cover, internal PCB's and field wiring are securely in place before applying power.
- Do not expose the GDS-49 to electrical shock or continuous severe mechanical shock. Protect the GDS-49 and related sensor assemblies from dripping liquids and high power sprays.
- Calibrate with known target gas at start-up and check on a regular schedule, at least every 90 days. More frequent inspections are encouraged to spot problems such as dirt, oil, paint, grease or other foreign materials on the sensor head.
- Periodically test for correct operation of the system's alarm events by exposing the monitor to a targeted gas concentration above the High Alarm set point.
- Use only for applications described within this manual.

2 GENERAL INFORMATION

The GDS-49 Remote Sensor Transmitter is designed to convert the low level 'micro amp' output signals from electrochemical toxic gas sensors into an uncalibrated 4-20mA current sink ("loop powered") output suitable for transmission over long distances. The GDS-49 is ideally suited for installation where reliability and cost are critically important and where a local display is not required.

Features

- Standard 4 to 20 mA output (current sink)
- Certified for use in Class I Division 1, Groups B, C & D hazardous areas for non-reactive gases (10-0248)
- Certified for use in Class I Division 1, Groups B, C & D hazardous areas for all gases when installed as Intrinsically Safe with appropriate IS barrier (10-0248IS)
- Easily-replaceable sensor element
- Fault indication for sensor fail or missing sensor
- Non-polarized two-wire output eliminates wiring errors
- Constructed of 316 stainless steel
- Reliable electrochemical toxic sensor technology



Electrochemical Sensors operate on the principle that the presence of a target gas causes a chemical reaction that produces free electrons in an electrolyte solution. These electrons flow through an external circuit to provide an indication of the amount of gas present. In addition, there is a separate circuit that feeds electrons back into the sensor to maintain the electrolyte in an electrically balanced state. The GDS-49 incorporates this circuitry along with a 4-20mA output stage inside the sensor head.

Electrochemical sensors contain a fixed amount of active electrolyte depending on the range and expected lifetime exposure to the target gas. As the sensor ages, the electrolyte is used up and the amount of output per ppm of target gas decreases. At some point, the output value drops below an acceptable threshold and the sensor must be replaced.

In general, electrochemical sensors are extremely reliable and offer excellent price / performance. However, users should be aware that extremes in temperature or relative humidity can cause an electrochemical sensor to lose sensitivity, and exposure to certain chemicals or gases can temporarily or, in some cases, permanently reduce the output or drive the sensor into a fault condition. For more information on specific sensor types, contact GDS Corp.

3 SPECIFICATIONS

- Model: GDS Corp Remote Sensor Transmitter for Toxic Gases
- Power Input: 4-20mA current loop; power consumption less than 0.25 watts max in over-range condition; typically less than 0.1watt
- Display: None
- Input: Direct connect toxic sensors for Oxygen, Carbon Monoxide, Chlorine, Chlorine Dioxide, Hydrogen, Hydrogen Sulfide, Hydrogen Cyanide, Hydrogen Chloride, Hydrogen Fluoride, Sulfur Dioxide, Ammonia, Ozone, Ethylene Oxide, Arsine, Silane, Fluorine, Phosgene, Hydrazine, Nitric Oxide, Nitrogen Dioxide, Mercaptan, THT, Diborane.
- NOTE: This list is not all-inclusive as many electrochemical sensors will respond to more than one gas. Contact GDS Corp for more details.
- Note: Certain 'sticky' gases require the removal of the flame arrestor for proper operation. For these situations, the GDS-49 is certified as Intrinsically Safe when installed with an appropriate IS barrier.
- Accuracy: +/- 5% of full scale (typical)
- Calibration: Output is factory adjusted but is not calibrated. Receiving device must provide zero and span (two-point) calibration. The GDS-49 is compatible with all GDS Corp controllers and third-party devices with 4-20mA inputs that provide two-point calibration capability.
- Output: 4-20 mA (current sink), max.750 ohm load at 24 VDC supply voltage
- Response: Determined by sensor type and range
- Time:
- Temperature: Electronics -25° to +60°C; sensor limits may vary
- Fault: Output drops to < 3mA to indicate sensor fault or missing sensor
- Indication:
- Housing: Junction box epoxy-coated aluminum, sensor head 316 stainless steel.
- Approvals: CSA Class 1, Division 1, Groups B, C and D Explosion Proof with flame arrestor; Intrinsically Safe for all sensors if used with IS barrier.
- Warranty: Two years on electronics, one year on sensor

10	Oxygen	-30°C to + 55°C	22	Ethylene Oxide	-20°C to + 50°C
11	Carbon Monoxide	-30°C to + 50°C	23	Arsine	-20°C to + 40°C
12	Chlorine	-20°C to + 50°C	24	Silane	-20°C to + 40°C
13	Chlorine Dioxide	-20°C to + 40°C	25	Fluorine	-10°C to + 40°C
14	Hydrogen	-20°C to + 50°C	26	Phosgene	-20°C to + 40°C
15	Hydrogen Sulfide	-30°C to + 50°C	27	Hydrazine	-10°C to + 40°C
16	Hydrogen Cyanide	-20°C to + 50°C	28	Nitric Oxide	-20°C to + 50°C
17	Hydrogen Chloride	-20°C to + 50°C	29	Nitrogen Dioxide	-20°C to + 50°C
18	Hydrogen Fluoride	-20°C to + 50°C	30	Mercaptan	-10°C to + 40°C
19	Sulfur Dioxide	-30°C to + 50°C	31	Tetrahydrothiophene	-10°C to + 40°C
20	Ammonia	-20°C to + 40°C	32	Diborane	-20°C to + 40°C
21	Ozone	-20°C to + 40°C	33	H2S Low Humidity	-20°C to + 40°C

Figure 3-1: Recommended Sensor Temperature Range

10	Oxygen	2 to 4 hours	22	Ethylene Oxide	8 to 12 hours
11	Carbon Monoxide	2 to 4 hours	23	Arsine	8 to 12 hours
12	Chlorine	8 to 12 hours	24	Silane	8 to 12 hours
13	Chlorine Dioxide	8 to 12 hours	25	Fluorine	8 to 12 hours
14	Hydrogen	2 to 4 hours	26	Phosgene	8 to 12 hours
15	Hydrogen Sulfide	2 to 4 hours	27	Hydrazine	8 to 12 hours
16	Hydrogen Cyanide	8 to 12 hours	28	Nitric Oxide	8 to 12 hours
17	Hydrogen Chloride	8 to 12 hours	29	Nitrogen Dioxide	8 to 12 hours
18	Hydrogen Fluoride	8 to 12 hours	30	Mercaptan	8 to 12 hours
19	Sulfur Dioxide	4 to 8 hours	31	Tetrahydrothiophene	8 to 12 hours
20	Ammonia	4 to 8 hours	32	Diborane	8 to 12 hours
21	Ozone	8 to 12 hours	33	H2S Low Humidity	2 to 4 hours

Figure 3-2: Recommended Sensor Warmup Times

Sensor Type	Sensor	Minimum Range	Maximum Range	Comments
10	Oxygen	0-25% by volume	0-25% by volume	
11	Carbon Monoxide	0-100 ppm	0-9999 ppm	
12	Chlorine*	0-5 ppm	0-50 ppm	
13	Chlorine Dioxide*	0-1 ppm	0-1 ppm	
14	Hydrogen	0-1000 ppm	0-4% by volume	
15	Hydrogen Sulfide	0-10 ppm	0-9999 ppm	
16	Hydrogen Cyanide	0-30 ppm	0-30 ppm	
17	Hydrogen Chloride*	0-30 ppm	0-30 ppm	
18	Hydrogen Fluoride*	0-5 ppm	0-10 ppm	
19	Sulfur Dioxide	0-50 ppm	0-500 ppm	
20	Ammonia*	0-50 ppm	0-1000 ppm	
21	Ozone*	0-1 ppm	0-1 ppm	
22	Ethylene Oxide	0-50 ppm	0-200 ppm	
23	Arsine	0-1 ppm	0-1 ppm	
24	Silane	0-25 ppm	0-50 ppm	
25	Fluorine*	0-1 ppm	0-1 ppm	
26	Phosgene*	0-1 ppm	0-1 ppm	
27	Hydrazine	0-1 ppm	0-1 ppm	
28	Nitric Oxide	0-25 ppm	0-100 ppm	
29	Nitrogen Dioxide	0-50 ppm	0-200 ppm	
30	Mercaptan	0-15 ppm	0-30 ppm	
31	Tetrahydrothiophene	0-15 ppm	0-30 ppm	
32	Diborane	0-1 ppm	0-5 ppm	
33	H2S Low Humidity	0-100 ppm	0-500 ppm	

Figure 3-3: Sensor Minimum and Maximum Ranges

Note: * denotes 'sticky' gas that requires IS installation in hazardous areas

4 INSTALLATION

CHOOSING A LOCATION

Factors such as air movement, gas density, emission sources and environmental variables affect sensor location. Air movement by fans, prevailing winds and convection should be carefully evaluated to determine if a leak is more likely to raise gas levels in certain areas within the facility. Vapor density of a gas determines if it will rise or fall in air when there are no significant currents. Lighter than air gases should have the monitors mounted 12 – 18 inches (30 – 45 cm) above the potential gas leak and heavier than air gases should be this distance below. Even though the GDS-49 sensor transmitter is designed for rugged service, it should be protected from environmental damage from water, snow, shock, vibration and dirt.

The GDS-49 should always be mounted with the sensor head opening facing down. If necessary, a Splash Guard (p/n 10-0205) should be attached if there is any chance that water or liquid spray could enter the sensor opening from below. Be sure to leave sufficient room (~ 12") below the sensor head to allow easy access for attachment of a Calibration Cup and / or removal of the sensor head cover for sensor replacement.

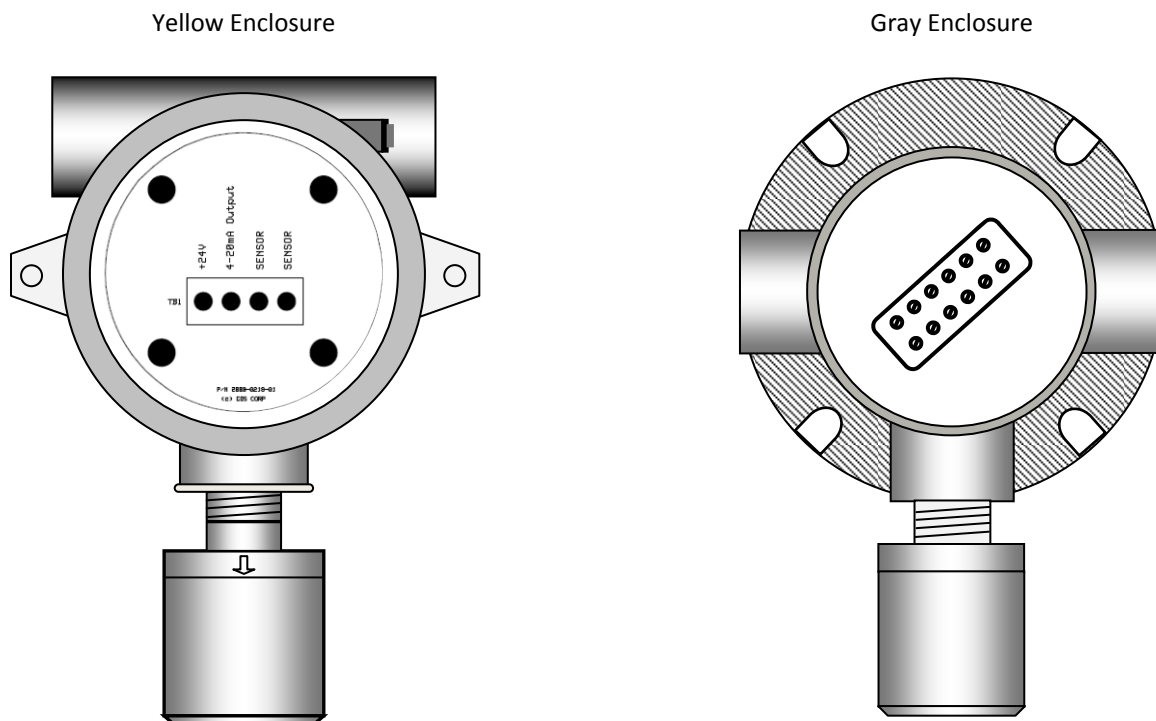

Figure 4-1: GDS-49 Remote Sensor Transmitter

ELECTRICAL CONNECTIONS

The GDS-49 is a two-wire, loop-powered sensor transmitter that derives its power from the current flowing in the loop. The electronics require approximately 9VDC to operate properly. That means that if the loop excitation voltage is 24VDC, then approximately 15VDC can be dissipated in the wiring and loop load resistors. The output is non-polarized, so either terminal of the GDS-49 can be connected to the positive side of the loop.

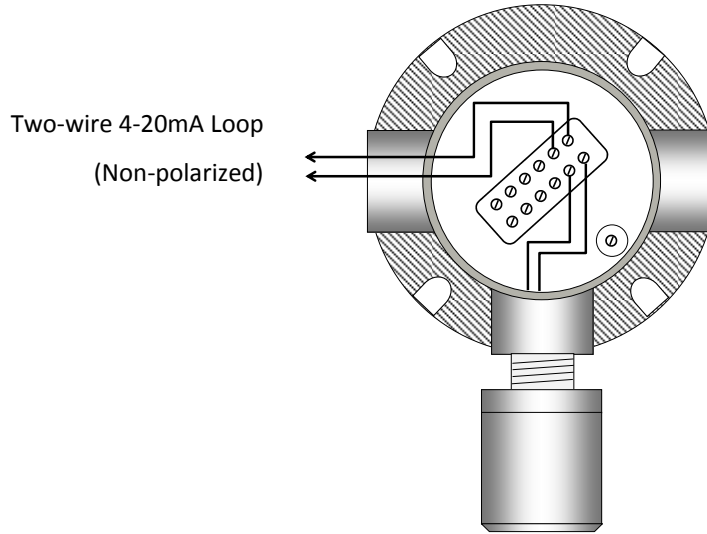

Figure 4-2: GDS-49 Wiring Connections (Gray Enclosure)

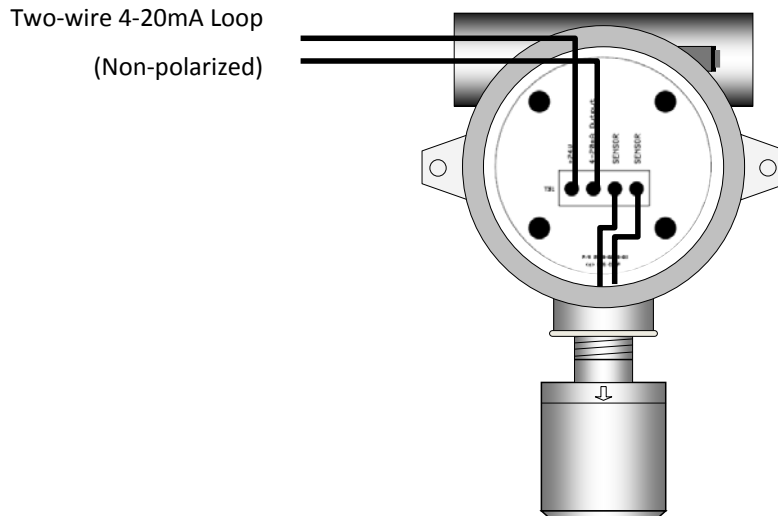

Figure 4-3: GDS-49 Wiring Connections (Yellow Enclosure)

Shielded cable is always recommended. Wiring should be installed in metal conduit with no other cabling in the same conduit. When power is initially applied to the GDS-49 the 4-20mA output may momentarily indicate a temporary off-scale low (FAULT) or off-scale high (OVERRANGE) value before settling down. All GDS Corp controllers provide a 'warm up' interval during which the sensor input is ignored. This keeps the controller from indicating an alarm due to sensor warm-up characteristics.

Total warm-up time is dependent on the type of sensor and range selected. GDS Corp recommends a four to eight hour interval between initial power-on and first calibration. If the sensor has been powered up, and has only been offline for a few hours, the warm-up time will be shorter.

5 CALIBRATION

CALIBRATION OVERVIEW

The GDS-49 does not have the capability to perform zero and span calibration. Each sensor includes a fixed gain resistor that establishes the approximate baseline output for any given gas concentration, and final zero and span calibration must be performed by 4-20mA signal receiving device.

Follow these GDS-49 calibration guidelines:

- Calibration accuracy is only as good as the calibration gas accuracy. GDS Corp calibration gases are traceable to NIST (National Institute of Standards and Technology).
- **Never use calibration gas that has passed its expiration date.**
- Always use a GDS Corp calibration cup that completely surrounds the sensor head.
- Be sure to use ZERO AIR, a mixture of 21% oxygen and 79% nitrogen, as a zero reference unless you are certain that no target gas exists in the area. Ambient gas may result in an 'elevated zero' condition that will cause a FAULT to occur once the ambient gas is no longer present.
- GDS Corp recommends using a span gas that is between 25% and 75% of full scale. GDS Corp does not recommend using full scale as the span set point.
- **Always calibrate a new sensor before depending on the device for personnel or equipment safety**
- Calibrate on a regular schedule. GDS Corp recommends a full calibration every 3 months, with periodic 'bump tests' on a more frequent basis to ensure that the sensor has not been affected by temperature extremes or the presence of incompatible gases.

In general, calibration involves applying a zero reference gas and telling the receiving device to accept that output as 'zero', followed by the application of a span reference gas and then telling the receiving device to accept the new output as 'span' once the output has stabilized. This is generally performed by two persons, one at the sensor transmitter and one at the receiving device. Actual procedures, time intervals and techniques for indicating zero and span values depend on the specific receiving device. All GDS Corp display and alarm controllers provide the necessary local calibration capability.

GENERALIZED CALIBRATION PROCEDURE

Before beginning calibration, make sure you have the following items: A cylinder of calibration gas, fixed flow regulator and an appropriate calibration cup connected to the regulator via a length of flexible tubing. If necessary, a cylinder of 'zero air' may be necessary if the absence of target gas cannot be confirmed. For chlorine, chlorine dioxide and hydrogen cyanide, GDS Corp recommends a flow rate of 1.0 liter / minute. For all other gases, a flow rate of 0.5 liters / minute is appropriate.

The actual steps involved in calibration vary depending on the receiving device, but can be generalized as follows:

1. Select the appropriate channel on the controller or receiver and enable Calibration Mode. This should disable alarms during the calibration process. Make sure that the controller's Cal Span value matches the cylinder of calibration gas.
2. Apply zero air to the sensor as shown in Fig. 6-1 or confirm the absence of any target gas.
3. At the controller or receiver, press the "Set Zero" button to confirm that the current reading is 'zero'.
4. Apply span gas to the sensor as shown in Fig 6-1.
5. At the controller or receiver, monitor the output until it stabilizes. When stable, press the "Set Span" button to confirm that the current reading corresponds to the Span value.
6. Turn off the regulator and remove the calibration cup from the sensor head.
7. At the controller or receiver, exit Cal Mode and resume normal operation.

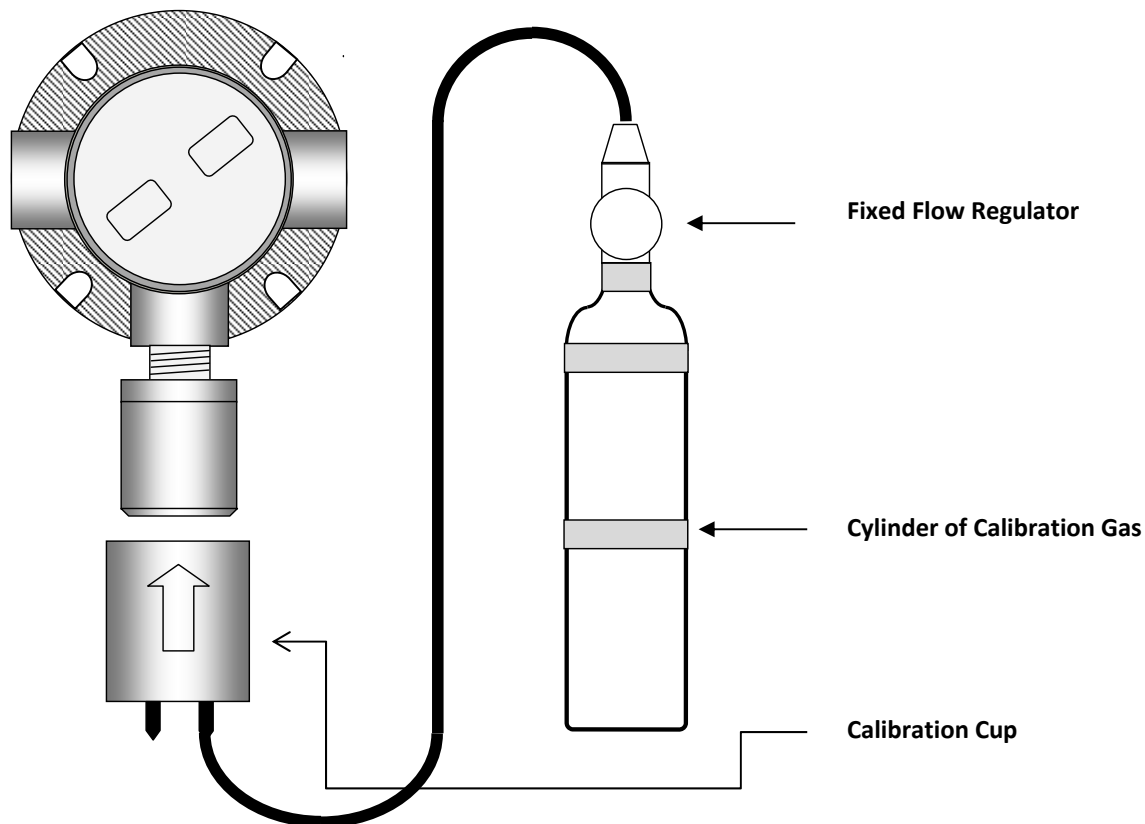

Figure 5-1: Applying Calibration Gas to GDS-49

6 OPERATION AND MAINTENANCE

In the normal operating mode, the 4-20 mA signal level corresponds to the detected gas concentration. In the event of a significant gas release, the GDS-49 will indicate an overrange condition up to approximately 30mA if the sensor's output continues to increase beyond the full scale value. In the event that the sensor output drops below zero due to interference gases or sensor failure, the 4-20mA output will drop to approximately 2.2mA, indicating a FAULT condition to the remote receiver or controller. If the sensor is removed, the output will also drop to 2.2mA.

The GDS-49 should be checked regularly for damage, water ingress or flame arrestor clogging due to excessive dust or dirt. If the flame arrestor has become contaminated by dust, dirt or moisture, remove the sensor head cover (after first making sure to declassify the area) and carefully clean with compressed air. Use of solvent is discouraged as remnants of the solvent material may affect the sensor. There are no user-serviceable components and maintenance is limited to cleaning and/or sensor replacement.

Some GDS Corp controllers and gas detectors monitor 'sensor life' by calculating a value between 0 and 100% based on the current response to calibration gas as compared to the initial response when the sensor was first installed. To ensure that the calculations are accurate, please make certain to follow the 'new sensor' installation instructions in the appropriate device manual.

SENSOR REPLACEMENT

If a sensor shows FAULT, does not respond to gas or can no longer be calibrated, it should be replaced. GDS-49 sensor transmitters use GDS Corp type 10-90XX sensors, where the XX is the gas type shown in Section 3. The range value should also be specified when ordering replacement sensors. For example, a replacement H₂S sensor for 0-100 ppm would be "10-9015-R0100".

To replace a sensor, review Fig. 6-1 and follow these steps:

1. Declassify the area or remove power to the GDS-49.
2. Unscrew the sensor head cover. If unable to open the cover by hand, use a Sensor Head Replacement Tool (p/n 10-0187).
3. Remove the old sensor by pulling straight down.
NOTE: PULL STRAIGHT DOWN. DO NOT TRY TO UNSCREW THE SENSOR.
4. Carefully install the replacement sensor by aligning the arrow on the sensor with the arrow engraved on the sensor head. Push straight up until the sensor connector seats firmly into the sensor connector.
5. Reinstall the sensor head cover by CAREFULLY screwing the cover onto the sensor head.

NOTE: IF THE SENSOR FALLS OUT OF THE SENSOR HEAD DURING THIS STEP, IT CAN BE DAMAGED. USE

CAUTION WHEN REINSTALLING THE SENSOR HEAD COVER.

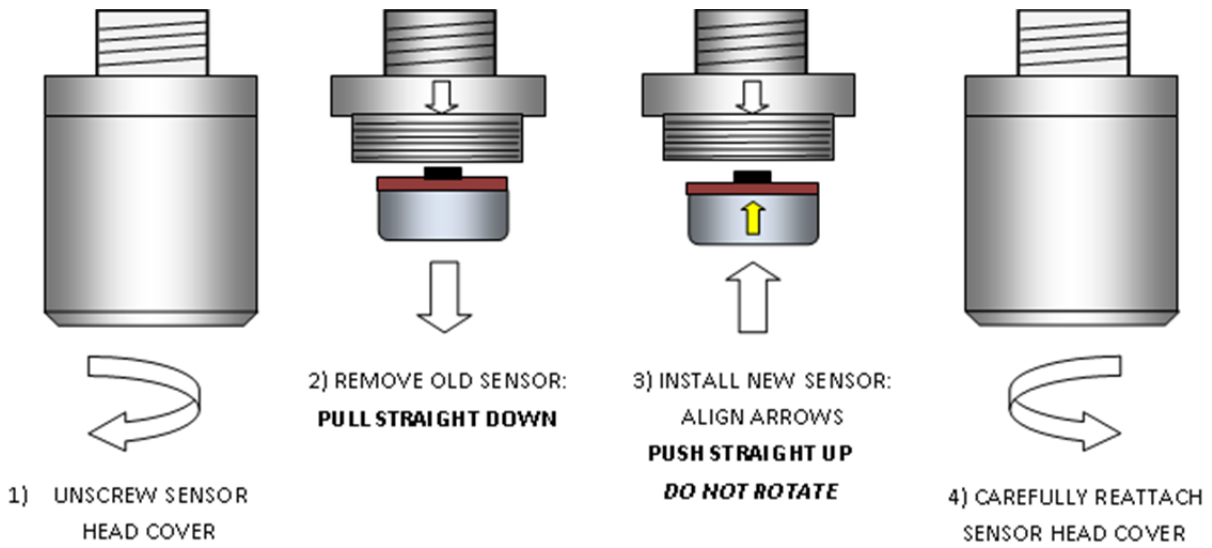
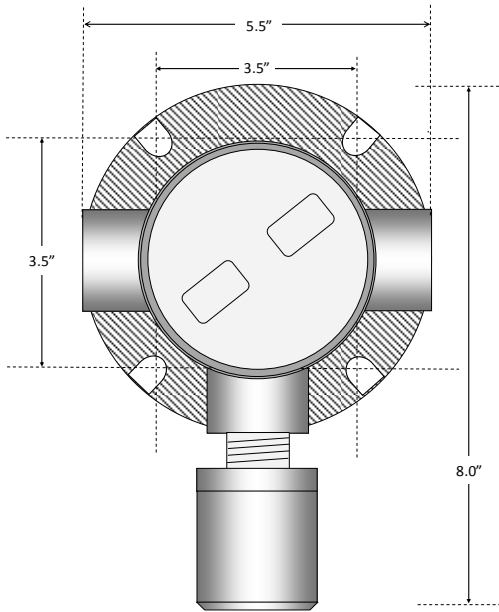

Figure 6-1: Sensor Replacement

7 SPARE PARTS

GRAY ENCLOSURE



Enclosure + Sensor Head (No sensor):

- 20-0129 Full assembly less sensor (gray)
- 20-0130 Full assembly less sensor (gray) for reactive gas

Enclosure / Junction Box Only:

- 20-0098 Gray junction box enclosure w/ PCB

Sensor Head Only:

- 10-0248 Toxic Sensor-Transmitter (Type 1-2)
 - 10-0248F Toxic S-T for Reactive Gas (Type 3-4)
- Note: Does not include sensor

Sensor:

- 10-90xx GDS Corp toxic sensor

YELLOW ENCLOSURE

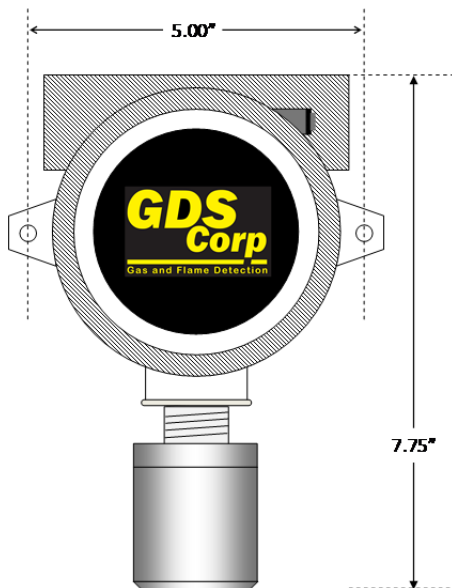

Enclosure + Sensor Head (No sensor):

- 20-0155 Full assembly less sensor (yellow)
- 20-0156 Full assembly less sensor (yellow) for reactive gas

Sensor Head:

- 10-0248 Toxic (Type 1-2)
 - 10-0248F Toxic Reactive Gas (Type 3-4)
- Note: Does not include sensor

Sensor:

- 10-90xx GDS Corp toxic sensor

SENSOR HEAD ACCESSORIES

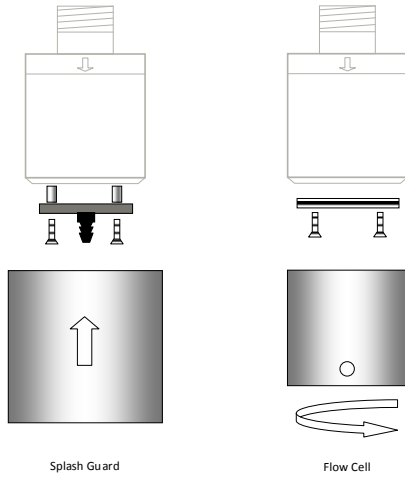

Sensor Head Splash Guard

10-0198 Splash Guard (Fits all sensor heads)

Sensor Head Flow Cell

10-0205 Flow Cell (1/8" NPT compression fittings)

20-0205S Other (specify)

8 DRAWINGS AND DIMENSIONS

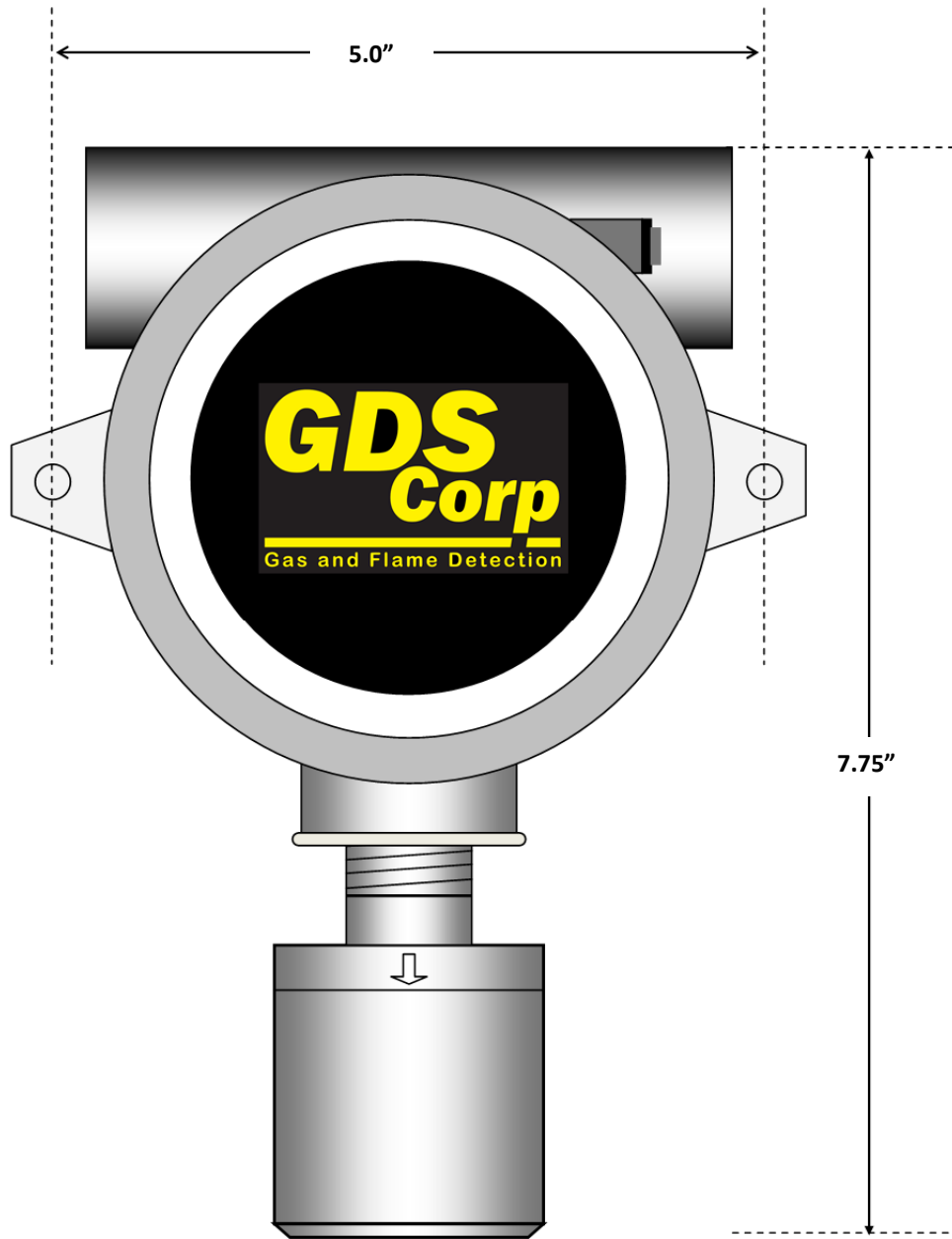

Figure 8-1: GDS-49 Yellow Housing

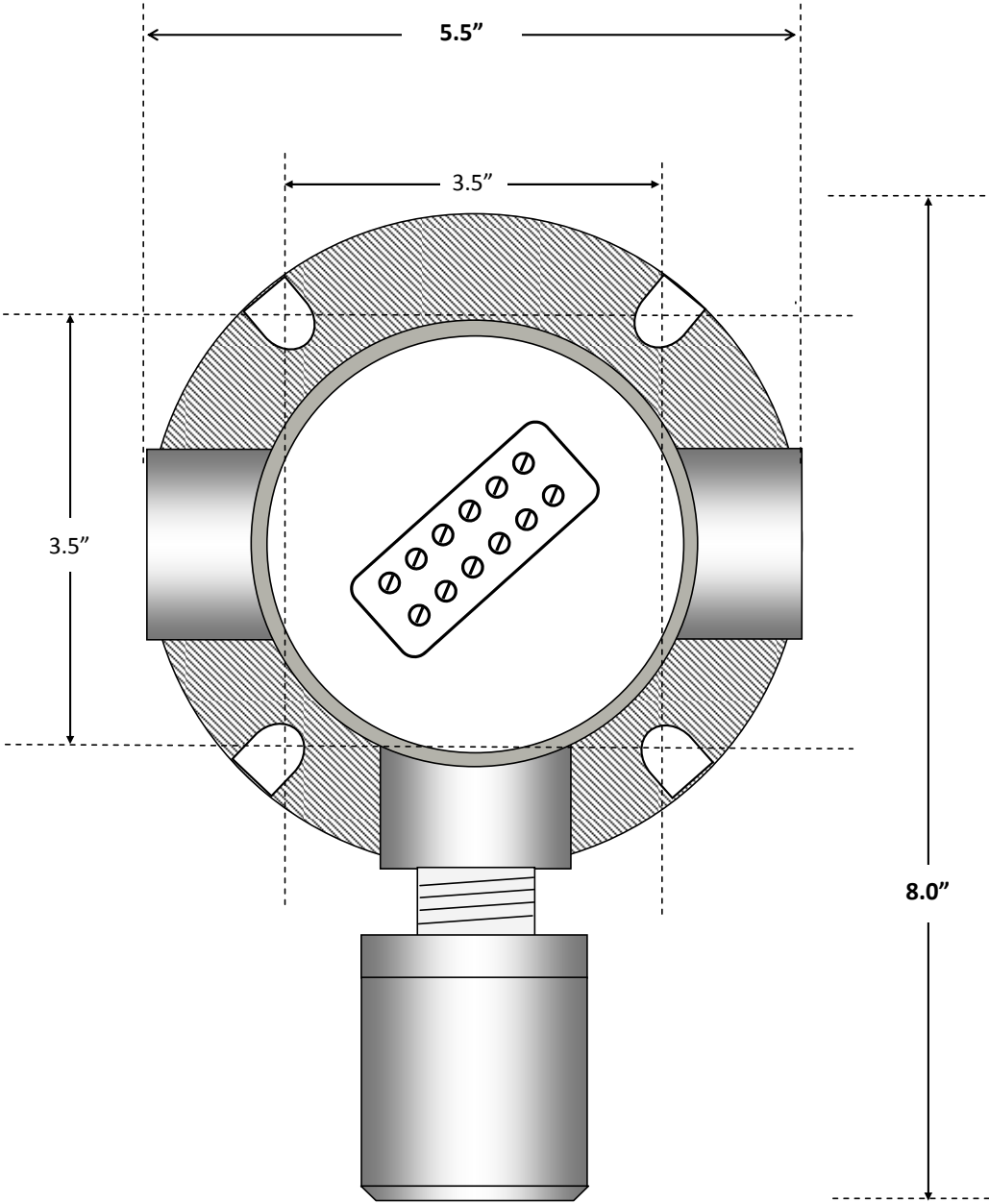

Figure 8-2: GDS-49 Gray Housing