



Gas and Flame Detection

Operation and Maintenance Manual

GDS-58XP Sample Draw System

GDS Corp.
2513 Hwy 646 • Santa Fe, Texas 77510
409-927-2980 • 409-927-4180 (Fax) • www.gdscorp.com

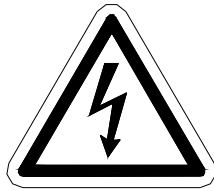

CAUTION: FOR SAFETY REASONS THIS EQUIPMENT MUST BE OPERATED AND SERVICED BY QUALIFIED PERSONNEL ONLY. READ AND UNDERSTAND INSTRUCTION MANUAL COMPLETELY BEFORE OPERATING OR SERVICING.

ATTENTION: POUR DES RAISONS DE SÉCURITÉ, CET ÉQUIPEMENT DOIT ÊTRE UTILISÉ, ENTRETENU ET RÉPARÉ UNIQUEMENT PAR UN PERSONNEL QUALIFIÉ. ÉTUDIER LE MANUE D'INSTRUCTIONS EN ENTIER AVANT D'UTILISER, D'ENTREtenir OU DE RÉPARER L'ÉQUIPEMENT.

REVISION HISTORY

Revision 3.0 6/1/13 Initial rewrite

Copyright © 2013 GDS Corp. All Rights Reserved
P/N 1200-0638-05

CONTENTS

1	SAFETY INFORMATION	9
2	GENERAL INFORMATION	10
	Introduction	10
	Getting Started	10
3	SPECIFICATIONS	11
4	THEORY OF OPERATION	14
	Overview	14
	GDS-58XP Sensors	14
5	INSTALLATION	16
	Selecting a Location	16
	Sampling Applications	16
	Mounting the GDS-58XP	17
	Connecting Inlet tubing	17
	Sample Exhaust	18
	DC Power & Signal Connections	18
	Relay Connections	18
	Optional Analog Wiring Junction Box [RWJB]	19
	MODBUS Connections	20
	Optional MODBUS Wiring Junction Box [MJB]	20
	Explosion Proof Installation	21
	Intrinsically Safe Installation	21
	User Interface Basics	22
	Getting Started	22

6	CALIBRATION	23
	Calibration Overview	23
	Calibration Procedure	23
7	OPERATION and MAINTENANCE	26
	Normal Operation	26
	GDS-58XP Display Screens	26
	Relay Functionality	27
	Sensor Replacement – toxic and bridge sensors	28
	Normal Maintenance	30
8	USER MENUS	31
	Main Menu	31
	System Configuration Page	32
	Measurement Name	32
	Eunits	32
	Zero (0%)	32
	Span (100%)	32
	Decimal Points	32
	Cal Span Value	32
	Readout Deadband	32
	Track Negative	32
	Temp Compensation	33
	Backup Config	33
	Restore Config	33
	Upload Sensor Data	33
	Cal Marker	33
	TX Sensor Life	33
	Alarm Settings Page	34
	Set Point	34
	Dead-Band	34
	ON Delay	35

OFF Delay _____	35
Low Trip _____	35
Latching _____	35
Display Event Log _____	35
Clear Event Log _____	35
RS-485 MODBUS Setup _____	35
Sensor Information Page _____	35
Install New Sensor _____	36
Recall Cal History _____	36
Input Type _____	36
New Sensor _____	36
Recent Cal _____	36
Clock / Delay Setup Page _____	36
Time _____	37
Date _____	37
Warm Up Delay _____	37
Cal Purge Delay _____	37
LCD Contrast Adjustment Page _____	37
HELP Screen Page _____	37
Diagnostics Page _____	37
Output Simulation _____	37
Relay Test _____	38
System Security Page _____	38
Contact Name _____	38
Secure Level _____	38
9 TECHNICIANS MENUS _____	39
XMITTER CONFIG Menu _____	39
O2 / Toxic _____	39
LEL / Current _____	39
Output Zero / Span Trim _____	39
Real Time Clock _____	39

Model _____	39
TECHNICAL PAGE Menu _____	40
Set Balance _____	40
Set Voltage _____	40
Set Gain to Unity _____	41
Preamp Gain Set _____	41
Zero Cal Value _____	42
Raw Min / Max Counts _____	42
Marker Active _____	42
Marker TX LED _____	43
Mark Level _____	43
Mark As Message _____	43
10 MODBUS REGISTERS _____	44
List of GDS-58XP MODBUS variables _____	44
Channel Status Word Bit Definition _____	46
Alarm Status Word Bit Definition _____	47
Transmitter Status Word Bit Definition _____	47
Channel Floating Point Definition _____	47
11 TROUBLESHOOTING GUIDELINES _____	48
Toxic Sensor Indicates Fault or Overrange _____	48
Toxic Sensor Will Not Calibrate _____	48
Bridge Sensor Indicates Fault or Overrange _____	48
Bridge Sensor Will Not Calibrate _____	48
Receiving Device and GDS-58XP Displayed Values Don't Match _____	49
Controller MODBUS Data Incorrect _____	49
Controller Showing MODBUS COMM ERROR _____	49
GDS-58XP Display Blank _____	49
GDS-58XP Error Codes _____	49

12	SPARE PARTS	51
13	DRAWINGS AND DIMENSIONS	53
14	WIRING DIAGRAMS	60
15	Sample Draw Duct Assembly 20-0141	63

TABLE OF FIGURES

FIGURE 3-1: TOXIC SENSOR CHARACTERISTICS	12
FIGURE 3-2: BRIDGE STYLE SENSOR CHARACTERISTICS	12
FIGURE 3-3: GDS-IR INFRARED SENSOR CHARACTERISTICS	13
FIGURE 4-1: GDS-58XP FLOW DIAGRAM	14
FIGURE 5-1: GDS-58XP AMBIENT AIR SAMPLING	16
FIGURE 5-2: GDS-58XP AIR DUCT SAMPLING	16
FIGURE 5-3: GDS-58XP WITH TOXIC SENSOR	17
FIGURE 5-4: GDS-58XP POWER & SIGNAL WIRING	18
FIGURE 5-5: RELAY / MODBUS CONNECTIONS	19
FIGURE 5-6: GDS-58XP WITH ANALOG WIRING JUNCTION BOX [RWJB]	19
FIGURE 5-7: MODBUS WIRING JUNCTION BOX	20
FIGURE 5-8: GDS-58XP WITH MODBUS WIRING JUNCTION BOX [MBJB]	21
FIGURE 6-1: GDS-58XP CALIBRATION SETUP	24
FIGURE 6-2: CALIBRATION FLOWCHART	25
FIGURE 7-1: GDS-58XP DATA, TREND AND DUAL DISPLAY	26
FIGURE 7-2: GDS-58XP DISPLAY SEQUENCE (TOXIC SENSOR)	27
FIGURE 7-3: SMART SENSOR IDENTIFICATION	28
FIGURE 7-4: SENSOR REPLACEMENT	29
FIGURE 8-1: MAIN MENU FLOWCHART	31
FIGURE 8-2: SYSTEM CONFIG MENU	32
FIGURE 8-3: SENSOR LIFE TRANSMISSION FORMAT	34
FIGURE 8-4: ALARM SETTINGS MENU	34
FIGURE 8-5: RS-485 MODBUS SETUP MENU	35
FIGURE 8-6: SENSOR SETTINGS MENU	36
FIGURE 8-7: CLOCK DELAY MENU	36
FIGURE 8-8: CONTRAST MENU	37
FIGURE 8-9: DIAGNOSTICS MENU	37

FIGURE 8-10: SYSTEM SECURITY MENU.....	38
FIGURE 9-1: XMITTER CONFIG MENU.....	39
FIGURE 9-2: TECHNICAL PAGE MENU.....	40
FIGURE 9-3: SENSOR BALANCE & VOLTAGE SET MENU.....	41
FIGURE 9-4: SET GAIN TO UNITY MENU.....	41
FIGURE 9-5: PREAMP GAIN SET MENU.....	42
FIGURE 12-1: GDS-58XP ASSEMBLY WITH TOXIC / BRIDGE SENSOR (SPARE PARTS).....	51
FIGURE 12-2: GDS-58XP STANDARD SENSOR HEAD EXPLODED VIEW.....	52
FIGURE 12-3: GDS-58XP ASSEMBLY WITH GDS-IR (SPARE PARTS).....	52
FIGURE 13-1: GDS-58XP DIMENSIONS (ALUMINUM ENCLOSURE).....	53
FIGURE 13-2: GDS-58XP DIMENSIONS (STAINLESS STEEL ENCLOSURE).....	54
FIGURE 13-3: GDS-58XP 17" X 15" MOUNTING PLATE DIMENSIONS.....	55
FIGURE 13-4: GDS-68XP 21" X 17" MOUNTING PLATE DIMENSIONS (AL ENCLOSURES).....	56
FIGURE 13-5: GDS-58XP 21" X 17" MOUNTING PLATE DIMENSIONS (SS ENCLOSURES).....	57
FIGURE 13-6: GDS-58XP WITH OPTIONAL STAINLESS STEEL COALESCING FILTER.....	58
FIGURE 13-7: GDS-58XP WITH OPTIONAL CLEAR COALESCING FILTER.....	59
FIGURE 14-1: GDS-58XP WIRING DIAGRAM (TOXIC SENSOR).....	60
FIGURE 14-2: GDS-58XP WIRING DIAGRAM (BRIDGE SENSOR).....	61
FIGURE 14-3: GDS-58XP WIRING DIAGRAM (GDS-IR SENSOR).....	62
FIGURE 15-1: SAMPLE DRAW DUCT ASSEMBLY.....	63
FIGURE 15-2: SAMPLE DRAW DUCT ASSEMBLY HOLE MOUNTING PATTERN.....	63

1 SAFETY INFORMATION

Important – Read Before Installation

Users should have a detailed understanding of GDS-58XP operating and maintenance instructions. Use the GDS-58XP only as specified in this manual or detection of gases and the resulting protection provided may be impaired. Read the following WARNINGS prior to use.

WARNINGS

- The GDS-58XP sample draw system described in this manual must be installed, operated and maintained in accordance with information contained herein. Installation in any hazardous area must comply with all applicable restrictions, requirements and guidelines for said hazardous areas. It is the end user customer's final decision to ensure that the GDS-58XP is suitable for the intended use.
- The GDS-58XP is designed and constructed to measure the level of certain gases in ambient air. Accuracy in atmospheres containing steam or inert gases cannot be guaranteed.
- Do not paint transmitter or sensor assembly.
- Do not operate the GDS-58XP if its enclosure is damaged or cracked or has missing components. Make sure the cover, internal PCB's and field wiring are securely in place before applying power.
- Do not expose the GDS-58XP to electrical shock or continuous severe mechanical shock. Protect the GDS-58XP from dripping liquids and high power sprays.
- Calibrate with known target gas at start-up and check on a regular schedule, at least every 90 days. More frequent inspections are encouraged to spot problems such as dirt, oil, paint, grease or other foreign materials in the sample tubing or in the sensor head.
- Periodically test for correct operation of the system's alarm events by exposing the sample extraction point to a calibration gas concentration above the High Alarm set point.
- Use only for applications described within this manual.

2 GENERAL INFORMATION

INTRODUCTION

The GDS-58XP is a single channel fixed-point gas monitor designed to provide continuous monitoring of toxic or combustible gases in remote locations, structures and air ducts.

Built-in Run/Calibrate sample valve and user-prompted calibration sequence makes it easy for one person to perform calibration and maintenance without opening the enclosure or declassifying the area.

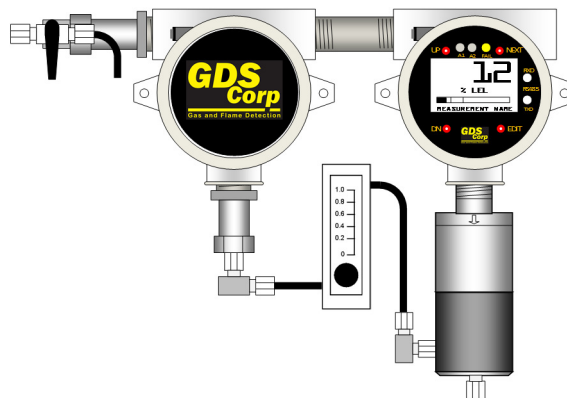

GETTING STARTED

To install and commission a GDS-58XP, perform the following steps:

- 1 Identify a suitable sample extraction point and mounting location.
- 2 Install the GDS-58XP in a vertical orientation, making sure there is room below for maintenance of the sensor housing and flow cell.
- 3 Install the sample inlet and exhaust tubing
- 4 Set the Run/Cal valve to the CAL position and apply power to the GDS-58XP. Verify that the flow meter shows 0.5 liters / minute or more. Allow the unit to warm up for the recommended time.

During Warmup, check the following settings:

- a) Check date and time for proper time zone.
 - b) Edit tag name if desired
 - c) Set MODBUS communications parameters
 - d) Set CAL SPAN value to match concentration of calibration gas cylinder.
 - e) Adjust CAL MARKER for desired output mA during calibration.
 - f) Set ALARM 1, ALARM 2 settings for desired levels
- 5 Once the unit has stabilized, perform a full zero and span calibration.
 - 6 Set the Run/Cal valve to Run and adjust the flow rate for 0.5 liters / minute. GDS Corp recommends applying calibration gas to the sample extraction point to verify end-to-end operation of the safety system and document the actual delay between extraction point and gas sensor.

3 SPECIFICATIONS

Model	GDS-58XP Sample Draw System
Power Input	24VDC \pm 5% at < 6 watts (Toxic or Bridge sensor) 24VDC \pm 5% at < 12 watts (GDS-IR sensor)
Display	64 x128 pixel LCD with engineering units, bargraph and 30-minute trend
Sensor Types	Electrochemical sensors for toxic gases Catalytic bead sensor for combustible gases Photoionization detector sensor for volatile organic compounds GDS-IR infrared sensor for combustibles and CO ₂
Draw Distance	Demonstrated up to 500 feet of ¼" OD tubing
Accuracy	+/- 5% of full scale (typical)
Standard Output	Three-wire 4-20mA current source outputs with fault and overrange indication. Maximum loop resistance is 750 ohms with standard 24VDC supply. Relay / MODBUS interface with 3x 5A SPDT programmable alarm relays. Fault relay indicates sensor failure or pump / flow failure
Temperature	0°C to +55°C Operating Note: Ambient temperature below 0°C may keep sample pump from starting
Memory	On-board non-volatile memory retains all user settings
Housing	Aluminum housings (2) with epoxy paint standard #316 stainless steel optional
Dimensions	Width 15" (381 mm), Height 10.5" (267 mm), Depth 5" (127 mm) Shipping weight 16 pounds (7.25 kg), 20"x20"x14" 17" wide x 15" tall painted steel or 304 stainless steel plate 21" wide x 17" tall painted steel or 316 stainless steel plate
Approvals	GASMAX monitor CSA Certified Div 1 & 2 Groups B, C, D. Enclosure CSA certified for use in Class I Div 1 areas. Flame arrestors UL certified for use in Class 1 Div 1 areas.
Warranty	Two years on electronics, one year on sensor

	Sensor Type	Min Range	Max Range	Temp Range	Warm-Up
10	Oxygen	0-25% v/v	0-25% v/v	0°C to + 55°C	2 to 4 hours
11	Carbon Monoxide	0-100 ppm	0-9999 ppm	0°C to + 50°C	2 to 4 hours
14	Hydrogen	0-1000 ppm	0-4% v/v	0°C to + 50°C	2 to 4 hours
15	Hydrogen Sulfide	0-10 ppm	0-9999 ppm	0°C to + 50°C	2 to 4 hours
16	Hydrogen Cyanide	0-30 ppm	0-30 ppm	0°C to + 50°C	8 to 12 hours
19	Sulfur Dioxide	0-50 ppm	0-500 ppm	0°C to + 50°C	4 to 8 hours
22	Ethylene Oxide	0-50 ppm	0-200 ppm	0°C to + 50°C	8 to 12 hours
23	Arsine	0-1 ppm	0-1 ppm	0°C to + 40°C	8 to 12 hours
24	Silane	0-25 ppm	0-50 ppm	0°C to + 40°C	8 to 12 hours
27	Hydrazine	0-1 ppm	0-1 ppm	0°C to + 40°C	8 to 12 hours
28	Nitric Oxide	0-25 ppm	0-100 ppm	0°C to + 50°C	8 to 12 hours
29	Nitrogen Dioxide	0-50 ppm	0-200 ppm	0°C to + 50°C	8 to 12 hours
30	Mercaptan	0-15 ppm	0-30 ppm	0°C to + 40°C	8 to 12 hours
31	THT	0-15 ppm	0-30 ppm	0°C to + 40°C	8 to 12 hours
32	Diborane	0-1 ppm	0-5 ppm	0°C to + 40°C	8 to 12 hours
33	H2S Low Humidity	0-100 ppm	0-500 ppm	0°C to + 50°C	2 to 4 hours

Figure 3-1: Toxic Sensor Characteristics

	Sensor Type	Min Range	Max Range	Temp Range	Warm-Up
61	PID, 10.6 eV, low range	0-50 ppm	0-5000 ppm	0°C to + 55°C	4 to 8 hours
62	PID 10.6 eV, high range	0-100 ppm	0-9999 ppm	0°C to + 55°C	4 to 8 hours
63	PID, 9.6 eV, low range	0-10 ppm	0-100 ppm	0°C to + 55°C	4 to 8 hours
64	PID, 10.0 eV, low range	0-5 ppm	0-50 ppm	0°C to + 55°C	4 to 8 hours
70	Catalytic Bead (Methane)	0-100% LEL	0-100% LEL	0°C to + 55°C	4 to 8 hours
71	Catalytic Bead (Other)	0-100% LEL	0-100% LEL	0°C to + 55°C	4 to 8 hours

Figure 3-2: Bridge Style Sensor Characteristics

	Sensor Type	Range	Temp Range	Warm-Up
109	Acetylene	0-100% LEL	0°C to + 55°C	4 to 8 hours
110	Methane	0-100% LEL	0°C to + 55°C	4 to 8 hours
111	Propane	0-100% LEL	0°C to + 55°C	4 to 8 hours
112	Isobutane	0-100% LEL	0°C to + 55°C	4 to 8 hours
113	Pentane	0-100% LEL	0°C to + 55°C	4 to 8 hours
114	Cyclopentane	0-100% LEL	0°C to + 55°C	4 to 8 hours
115	n-Butane	0-100% LEL	0°C to + 55°C	4 to 8 hours
116	Ethanol	0-100% LEL	0°C to + 55°C	4 to 8 hours
117	Methanol	0-100% LEL	0°C to + 55°C	4 to 8 hours
118	Propylene	0-100% LEL	0°C to + 55°C	4 to 8 hours
119	Ethylene	0-100% LEL	0°C to + 55°C	4 to 8 hours
120	Hexane	0-100% LEL	0°C to + 55°C	4 to 8 hours
121	Jet-A	0-100% LEL	0°C to + 55°C	4 to 8 hours
122	Diesel	0-100% LEL	0°C to + 55°C	4 to 8 hours
123	Gasoline	0-100% LEL	0°C to + 55°C	4 to 8 hours
124	Isopropyl Alcohol	0-100% LEL	0°C to + 55°C	4 to 8 hours
125	Acetone	0-100% LEL	0°C to + 55°C	4 to 8 hours
126	p-Xylene	0-100% LEL	0°C to + 55°C	4 to 8 hours
127	Ethylene Oxide	0-50% LEL	0°C to + 55°C	4 to 8 hours
128	MEK	0-100% LEL	0°C to + 55°C	4 to 8 hours
129	Styrene	0-50% LEL	0°C to + 55°C	4 to 8 hours
130	Methane (by volume)	0-100% v/v	0°C to + 55°C	4 to 8 hours
131	Propane (by volume)	0-100% v/v	0°C to + 55°C	4 to 8 hours
132	Carbon Dioxide	0-5.0% v/v	0°C to + 55°C	4 to 8 hours
133	Carbon Dioxide	0-3.5% v/v	0°C to + 55°C	4 to 8 hours

Figure 3-3: GDS-IR Infrared Sensor Characteristics

4 THEORY OF OPERATION

OVERVIEW

The GDS-58XP is designed to provide reliable gas detection in locations where the environment is not suitable for the installation of traditional ambient sensors. The GDS-58XP combines a highly reliable brushless DC sample pump, low flow detection switch, visual flow meter and GASMAX gas sample draw into a single unit that provides 4-20mA analog output, programmable relays including system FAULT and a MODBUS slave interface. The integrated Run/Cal switch and GASMAX user-prompted calibration procedure make normal maintenance quick and easy.

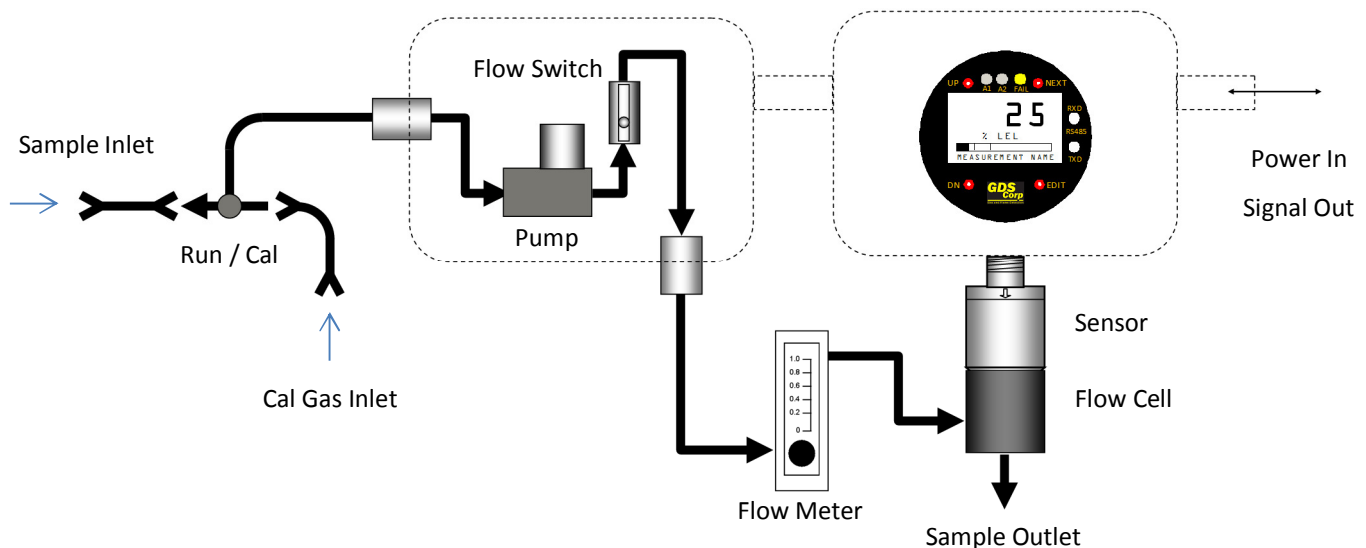

Figure 4-1: GDS-58XP Flow Diagram

Sample gas enters the unit through the Run/Cal valve where it is drawn into the explosion proof enclosure by the pump after passing through the first of two flame arrestors. Output from the pump is directed through the low flow switch and exits the explosion proof enclosure through the second flame arrestor where it travels to the flow meter and sensor flow cell and then exits the flow cell at ambient atmospheric pressure. Electronics in the GDS-58XP monitor the flow switch, sensor and internal circuitry and activate the FAULT relay if the sensor fails, if sample flow falls below a preset value or if the internal microprocessor becomes inactive.

GDS-58XP SENSORS

For toxic gases the GDS-58XP supports a wide range of electrochemical (“echem”) sensors. These sensors use chemical reactions to sense the presence of gases such as hydrogen sulfide, sulfur dioxide and many others. Each sensor contains an amount of chemical electrolyte that reacts with the target gas to create

free electrons that are amplified and measured. Once the electrolyte is depleted, sensor output will diminish and the sensor must be replaced.

IMPORTANT: TOXIC SENSORS ARE SUBJECT TO ACCELERATED DETERIORATION IF POWER IS NOT APPLIED WITHIN 3 MONTHS OF SHIPMENT FROM GDS CORP.

For combustible gases the GDS-58XP supports both a traditional catalytic bead (“cat bead”) sensor and the GDS-IR infrared sensor.

Catalytic bead sensors ‘burn’ combustible gas using a catalyst that operates at high temperature. An increase in temperature indicates the presence of gas. Catalytic bead sensors can detect any combustible gas, but the fact that the active bead is in direct contact with the gas can result in damage or reduced sensitivity if the gas contains chemicals that deactivate or temporarily inhibit the operation of the catalyst. Catalytic material is used each time the sensor is exposed to combustible gas and as a result the sensor will lose sensitivity over time.

Infrared sensors use the fact that hydrogen-carbon bonds found in all hydrocarbon gases absorb infrared light at certain frequencies. The sensor is designed such that the target passes between the source and detector, and a reduction in detector output indicates the presence of gas. Infrared sensors cannot be poisoned or damaged by chemicals in the target gas and typically have a long life. GDS-IR sensors carry a 5 year warranty on the electronics and a 12 year warranty on the IR source.

IMPORTANT: INFRARED SENSORS CANNOT DETECT COMBUSTIBLE LEVELS OF HYDROGEN GAS

Photoionization detectors (PID sensors) are used to detect volatile organic compounds such as benzene or toluene. PID sensors use high energy ultraviolet light to partially ionize complex molecules and measure the resulting free electrons. Each VOC has a different ‘ionization potential (IP)’ energy level that is measured in ‘electron-volts’, or eV, and a given PID sensor will detect all compounds present with IP values that are equal to or lower than the rated eV of the PID sensor lamp. PID sensor lamps eventually wear out and can be factory refurbished.

5 INSTALLATION

SELECTING A LOCATION

Select a location for the GDS-58XP that takes into account the distance to the sample inlet and exhaust point, a local source of DC power and easy access for maintenance and sensor replacement.

SAMPLING APPLICATIONS

When sampling from a static area, mount the GDS-58XP as close as possible to the extraction point and try to keep the unit above the point so that any moisture that condenses inside the tubing flows back to the source.. GDS Corp recommends the installation of #1200-0387 end-of-line dust filter at the pickup point if the area contains significant amounts of dust or particulates (See Fig. 5-1).

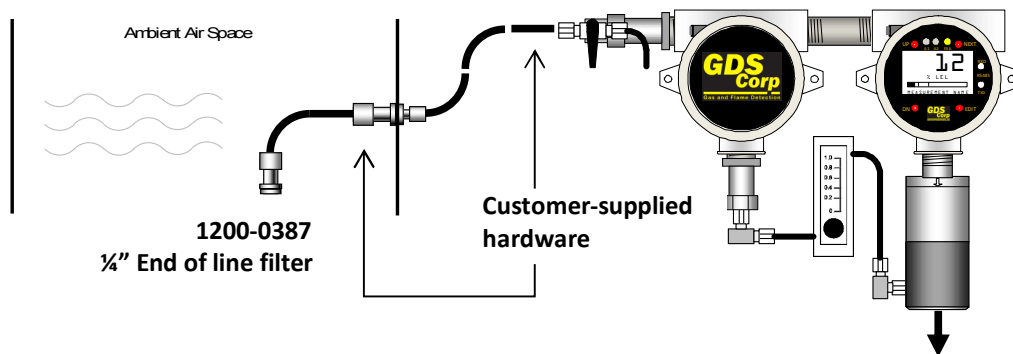

Figure 5-1: GDS-58XP Ambient Air Sampling

Sampling inside air conditioning ducts presents several problems for ambient sensors. Rapid air flow can damage the sensor, access for calibration or maintenance is difficult, and non-linear gas distribution can result in errors. Using a GDS-58XP with a #20-0141 Duct Sample Kit simplifies installation, maintenance and calibration and samples a larger cross-section of the duct stream (See Fig. 5-2).

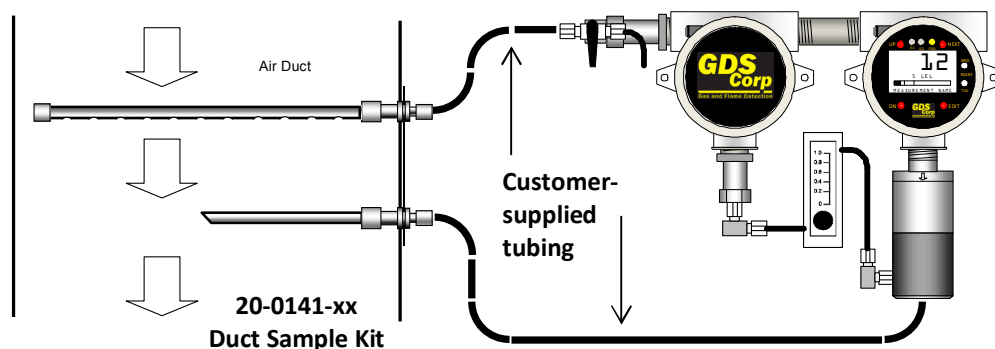

Figure 5-2: GDS-58XP Air Duct Sampling

MOUNTING THE GDS-58XP

The GDS-58XP standard enclosure is a dual cast aluminum explosion-proof (NEMA 7) enclosure as shown in Figure 5-3. The GDS-58XP is also available on a 14.5" x 17" painted steel plate and in 24" x 24" non-metallic and stainless steel enclosures (See Chap. 13). The GDS-58XP should be mounted vertically as shown for the flow switch and flow meter to operate properly.

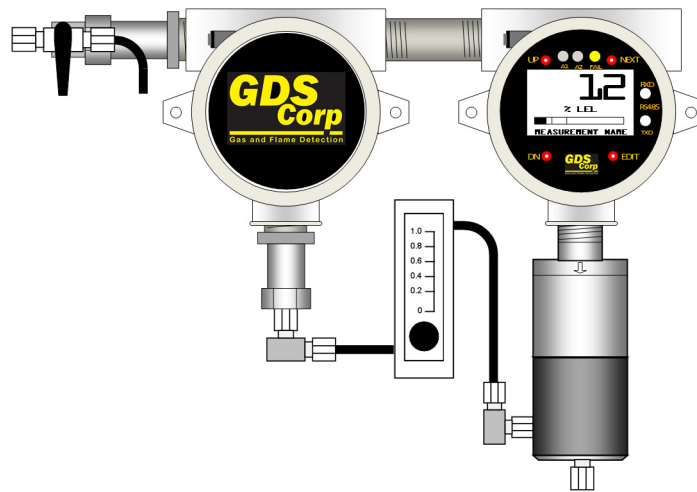

Figure 5-3: GDS-58XP with Toxic Sensor

CONNECTING INLET TUBING

Specifications for the inlet tubing depend on the target gas. Long runs of sample tubing will cause a significant delay between the appearance of gas and the resulting warning. Small diameter stainless steel (1/4" OD) is ideal for most gases. Flexible tubing or tubing manufactured from Teflon or PTFE may also be used.

Smaller diameter tubing results in faster response because of the lower total volume of gas that must be drawn from the sample point. Tests have shown that it takes approximately 3.5 minutes for a sample to be drawn through 500 feet of 1/4" OD flexible tubing; this gives a delay rate of roughly 0.4 seconds per foot of tubing. Larger diameter tubing with higher internal volume will result in a longer delay, while smaller tubing may be subject to blockage from condensed water droplets or dirt particles.

NOTE: THE SAMPLE PUMP IS CAPABLE OF PULLING UP TO 7.0 PSI VACUUM, ENOUGH TO LIFT WATER OVER 15 FEET. CARE SHOULD BE TAKEN NOT TO SUBMERGE THE SAMPLE EXTRACTION POINT IN LIQUID AS THE PUMP WILL QUICKLY FILL THE FLAME ARRESTORS, FLOW SWITCH, FLOW METER AND SAMPLE FLOW CELL WITH LIQUID.

Inlet Delay Calculation

For 1/4" OD tubing, allow 5 seconds delay for every 10 feet of sample line

SAMPLE EXHAUST

Changes in ambient pressure will affect the output from most sensors, and allowing the sample to exhaust directly to the atmosphere will minimize these affects. Long runs of tubing connected to the sample outlet may increase the backpressure inside the sensor flow cell and cause higher than normal readings. Returning a sample to a process stream may be desirable and will work if the process stream is only slightly above ambient (< 5" of water column) and has a relatively constant pressure.

IMPORTANT: DO NOT RESTRICT THE SAMPLE EXHAUST OUTLET. A BUILDUP OF PRESSURE IN THE SAMPLE FLOW CELL MAY DAMAGE THE SENSOR AND WILL RESULT IN INCORRECT READINGS.

DC POWER & SIGNAL CONNECTIONS

To access the GDS-58XP signal and power connections, remove the right-hand-side cover on the GDS-58XP explosion-proof enclosure, loosen the 2 thumbscrews holding the display assembly and remove it. The display will remain connected to the IO/Power Supply PCB mounted in the back of the enclosure by a short ribbon cable. Route the power and signal wires through the right-hand-side conduit entry and connect to terminal block "TB2" (see Fig. 5-2).

Recommended Wire Gauge	
< 100 ft	#18 GA
100 to 500 ft	#16 GA
500 to 1000 ft	#14 GA

Plus 24VDC connects to TB2-1 and DC Ground connects to TB2-4. Output from units with TOXIC sensors is available on TB2-2, while output from units with BRIDGE or GDS-IR sensors is output is available on TB2-3.

NOTE: GDS CORP ALWAYS RECOMMENDS USING SHIELDED WIRE FOR SIGNAL AND POWER CABLE.

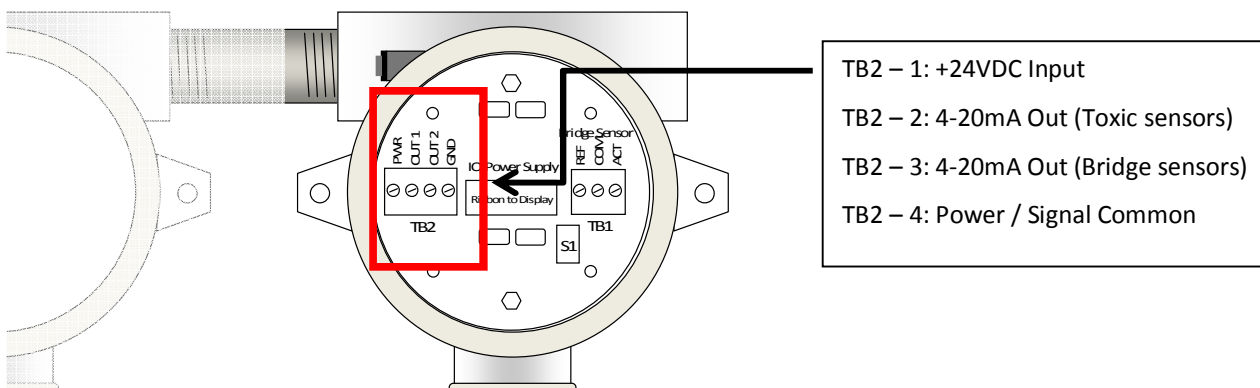

Figure 5-4: GDS-58XP Power & Signal Wiring

RELAY CONNECTIONS

The Relay / Modbus board is connected "piggyback" to the back of the GDS-58XP Display Assembly and supplies two level alarm relays, a FAULT relay and an RS-485 Modbus RTU slave port.

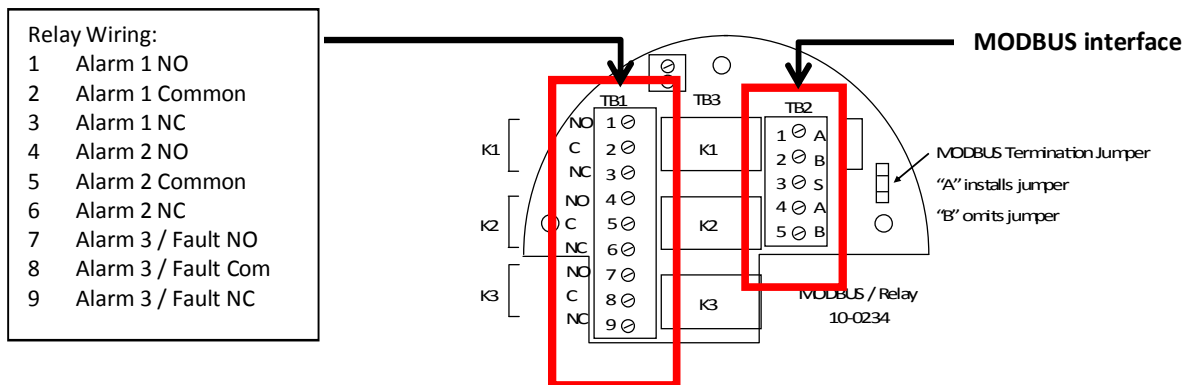

Figure 5-5: RELAY / MODBUS Connections

Relays K1 and K2 provide a contact closure if the Alarm 1 ("K1") or Alarm 2 ("K2") limits are exceeded. Alarms can be programmed to trigger above or below a certain value, work as normal or 'failsafe' and can be made to latch if desired.

WARNING: CONTACTS ARE RATED FOR RESISTIVE LOADS ONLY! INDUCTIVE LOADS, SUCH AS COILS, MOTORS OR SOLENOID VALVES MAY CAUSE ARCING AND INTERFERE WITH SENSOR DATA.

NOTE: RELAY K3 IS ALWAYS FAILSAFE, NORMALLY OPEN HELD CLOSED. K3 WILL ACTIVATE IF THE SENSOR OUTPUT EXCEED PRESET UPPER OR LOWER LIMITS OR THE FLOW SWITCH INDICATES A LOSS OF FLOW.

OPTIONAL ANALOG WIRING JUNCTION BOX [RWJB]

When interconnect wiring sizes are larger than #20 gauge the GDS-58XP can be fitted with an external analog wiring junction box.

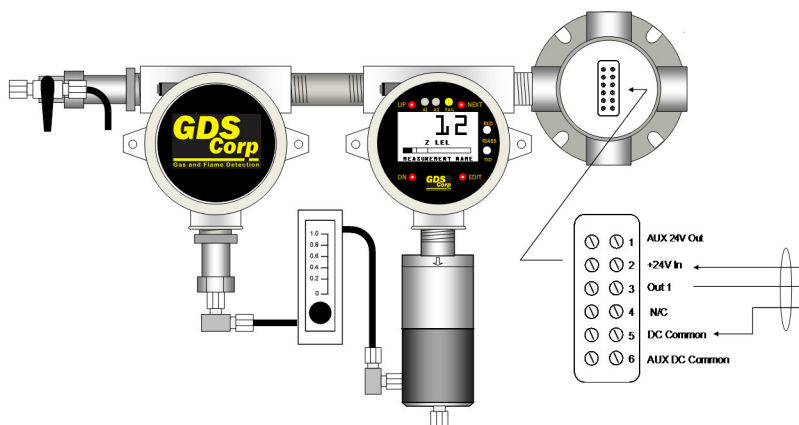

Figure 5-6: GDS-58XP with Analog Wiring Junction Box [RWJB]

MODBUS CONNECTIONS

The GDS-58XP provides a full MODBUS RTU slave interface that allows remote controllers or PLCs to monitor most aspects of operation, including real-time data, range and alarm setpoints and alarm and fault status bits (See Chapter 10 for a full listing of available MODBUS registers). The GDS-58XP supports 9600 Baud RS-485 differential signaling only.

Access to the MODBUS RS-485 interface is via TB2 on the Relay / MODBUS board mounted on the back of the GDS-58XP display module (See Fig. 5-5). Separate input and output terminals for MODBUS “A” and “B” signals are available. A center terminal to tie incoming and outgoing shield connections is also provided.

MODBUS system architecture requires that the devices in any MODBUS loop be connected in a daisy-chain layout. This minimizes signal reflections and improves signal noise margin. A MODBUS Termination Jumper installs a load resistor across the MODBUS signal lines and should only be set to “A” (ON) at the last device in the string (See Fig. 5-5).

Cable selection for MODBUS systems is important for both signal integrity and power distribution. MODBUS / RS-485 transmissions use low-voltage differential signaling to achieve reasonable data rates over very long distances, up to 4000 feet without a repeater. For MODBUS data signals, GDS Corp recommends 20GA to 24GA shielded cable. Daisy-chain power distribution may require larger gauge wire since it is critical that the supply voltage for the GDS-58XP at the far end of the string not fall below 22VDC during power-up.

OPTIONAL MODBUS WIRING JUNCTION BOX [MJB]

Note that while the GDS-58XP has two sets of wiring terminals for MODBUS “A” and “B” signals, daisy-chain power wiring requires that two wires be installed in the “+24” and “GND” terminals on the GDS-58XP I/O Power Supply board. This can be difficult if wire sizes are larger than #18GA. For these reasons, if MODBUS is required GDS Corp recommends the addition of the MODBUS Wiring Junction Box (see Fig. 5-7). This option minimizes the need to access wiring inside the GDS-58XP, provides individual wire landing points for incoming and outgoing MODBUS and power wiring and shields, and makes it easy to temporarily disconnect the GDS-58XP power or MODBUS connections without affecting any other MODBUS device.

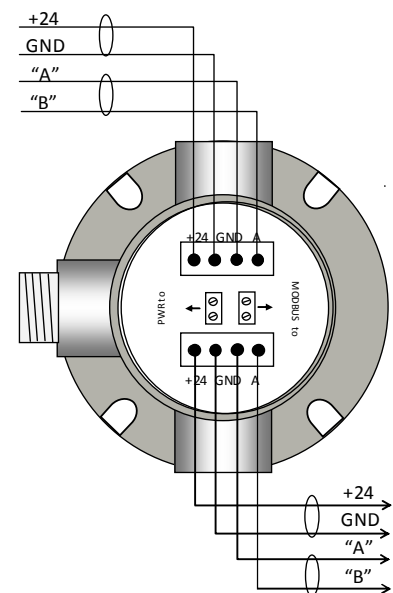

Figure 5-7: MODBUS Wiring Junction Box

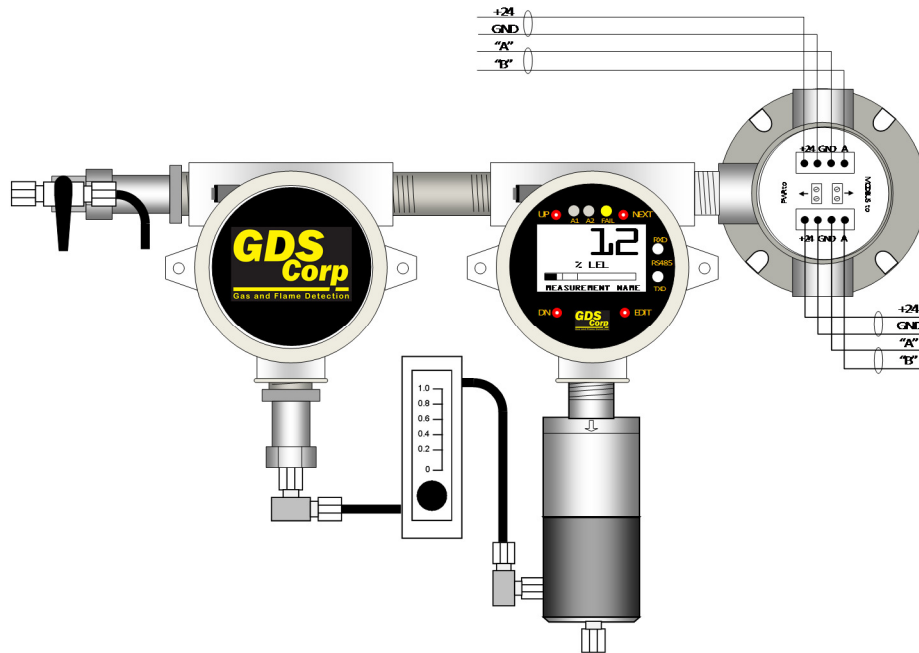

Figure 5-8: GDS-58XP with MODBUS Wiring Junction Box [MBJB]

EXPLOSION PROOF INSTALLATION

The GDS-58XP is designed for use in Class 1 Division 1 hazardous areas. Installation in these areas should follow best industry standard practices and all appropriate electrical codes. Generally, these codes require rigid metal conduit, poured seals and other installation elements necessary to ensure safety. For maximum protection against RF interference or electrical surge, the GDS-58XP enclosure and interconnecting conduit must be properly grounded.

INTRINSICALLY SAFE INSTALLATION

The GDS-58XP is not certified for use as an Intrinsically Safe device.

USER INTERFACE BASICS

Once installed, apply power to the GDS-58XP and verify that the LCD display is active. There are four magnetic switches on the face of the GDS-58XP, arranged in a quadrant around the LCD display. Starting in the upper right and proceeding clockwise these are labeled NEXT, EDIT, DN/CAL and UP. To activate, or “press” a magnetic switch, swipe the magnet near the switch.

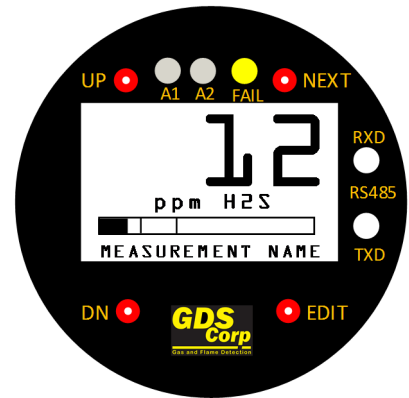

Pressing the NEXT key causes the GDS-58XP display to switch display screens between DATA 1, DATA 2, TREND 1, TREND 2 and DUAL CHANNEL.

The EDIT key activates the USER MENU display mode.

Activating DOWN/CAL, followed by EDIT, while in display mode initiates calibration mode. For the balance of this manual, the term “press” will be used to describe activation of any key via the magnetic wand.

GETTING STARTED

To install and commission a GDS-58XP, perform the following steps:

- 7 Identify a suitable sample extraction point and mounting location.
- 8 Install the GDS-58XP in a vertical orientation, making sure there is room below for maintenance of the sensor housing and flow cell.
- 9 Install the sample inlet and exhaust tubing
- 10 Set the Run/Cal valve to the CAL position and apply power to the GDS-58XP. Verify that the flow meter shows ~0.5 liters / minute or more. Allow the unit to warm up for the recommended time (See Fig. 3-1, 3-2 or 3-3). During Warmup, check the following settings:
 - a) Check date and time for proper values.
 - b) Edit tag name if desired
 - c) Set MODBUS communications parameters
 - d) Set CAL SPAN value to match concentration of calibration gas cylinder.
 - e) Adjust CAL MARKER for desired output mA during calibration
 - f) Set ALARM 1, ALARM 2 settings for desired levels
- 11 Once the unit has completed the necessary warm up, perform a full zero and span calibration.
- 12 Set the Run/Cal valve to Run and adjust the flow rate for 0.5 liters / minute. GDS Corp recommends applying calibration gas to the sample extraction point to verify end-to-end operation of the safety system and document the actual delay between gas appearing at the extraction point and gas sensor response.

6 CALIBRATION

CALIBRATION OVERVIEW

Calibration is critically important to ensure correct operation of the GDS-58XP. The built-in CAL MODE function is designed to make calibration quick, easy and error free; a successful ZERO and SPAN calibration requires only four keystrokes. During CAL MODE zero and span, the sensor output is disconnected and the GDS-58XP transmits a fixed mA value, called the CAL MARKER, to notify the receiving device that a calibration is in progress. During the following CAL PURGE DELAY time, the GDS-58XP transmits a fixed 4.0 mA signal to prevent external alarms during calibration. In the case of Oxygen sensors, during CAL PURGE DELAY the output simulates a typical atmospheric reading of 20.8%. CAL MODE automatically exits if no keystrokes are detected after 5 minutes.

Follow these GDS-58XP calibration guidelines:

- Calibration accuracy is only as good as the calibration gas accuracy. GDS Corp calibration gases are traceable to NIST (National Institute of Standards and Technology).
- **Never use calibration gas that has passed its expiration date.**
- Check the SPAN GAS VALUE setting and make sure it matches the calibration gas. (See Fig. 6-2)
- Always use a GDS Corp calibration cup that completely surrounds the sensor head.
- Be sure to use ZERO AIR, a mixture of 21% oxygen and 79% nitrogen, as a zero reference unless you are certain that no target gas exists in the area. Ambient gas may result in an 'elevated zero' condition that will cause a FAULT to occur once the ambient gas is no longer present.
- **Always calibrate a new sensor before depending on the device for personnel or equipment safety**
- Calibrate on a regular schedule. GDS Corp recommends a full calibration every 3 months, with periodic 'bump tests' on a more frequent basis to ensure that the sensor has not been affected by temperature extremes or the presence of incompatible gases.

CALIBRATION PROCEDURE

Before beginning calibration, make sure you have the following items: A cylinder of calibration gas, fixed flow regulator and a length of flexible tubing. A cylinder of 'zero air' may be necessary if the absence of target gas cannot be confirmed in the sample area.

To calibrate a GDS-58XP sample draw:

1. If using Zero Air, set the Run/Cal valve to the CAL position (pointing to the right) and connect the cylinder of zero air to the GDS-58XP calibration port. Turn on the regulator and verify flow on the flow meter. Otherwise, allow the current sample to continue to flow into the GDS-58XP.
2. Press the NEXT key until the corresponding DATA Display screen is shown.

3. Press the DOWN / CAL key and within 5 seconds press the EDIT key to enter CAL MODE.
4. The screen will display "APPLY ZERO". Allow a few seconds for the reading to stabilize and press the EDIT key to complete the ZERO calibration. A "ZERO CAL SUCCESSFUL" message should appear.
5. If not already done, set the Run/Cal value to the CAL position and connect the cylinder of span gas.
6. When the "APPLY SPAN" message appears, turn on the regulator and verify flow on the flow meter. After the reading is stable, (approximately 1-2 minutes) press the EDIT key to complete the SPAN GAS calibration. If the SPAN calibration is successful, the display flashes REMOVE CAL GAS and starts the CAL PURGE delay.
7. Immediately shut off the regulator and set the Run/Cal valve to RUN. At the end of the CAL PURGE delay, the GDS-58XP output is re-enabled and the unit is fully operational.

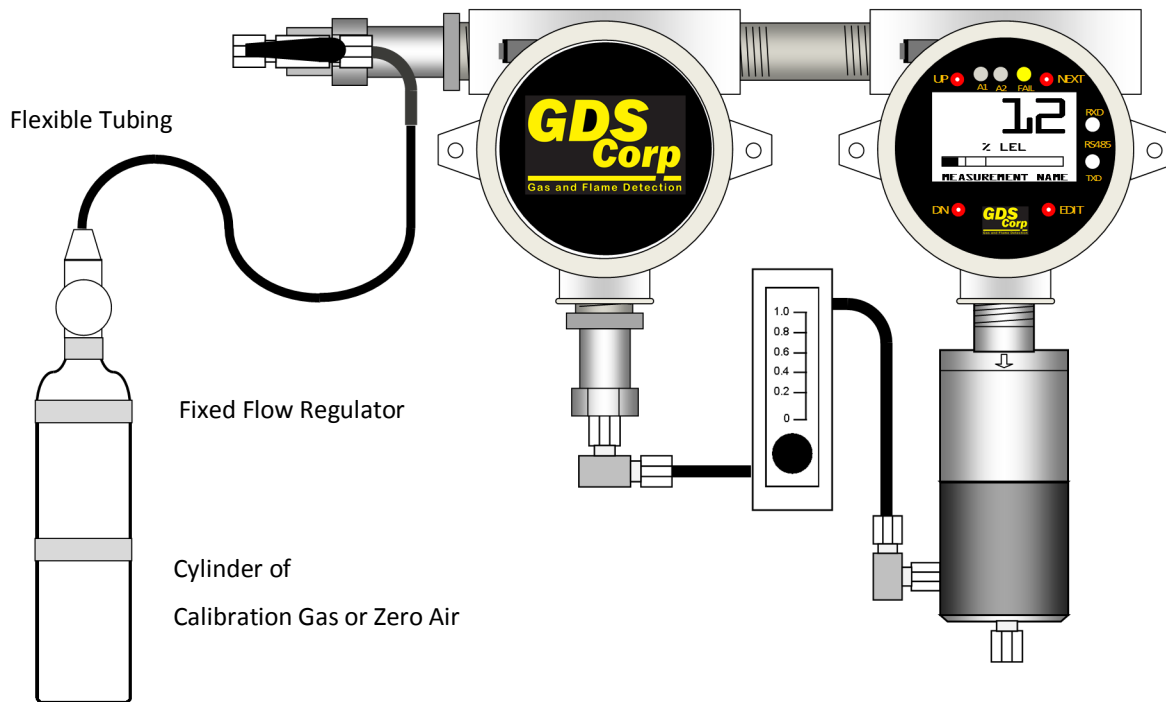

Figure 6-1: GDS-58XP Calibration Setup

The flow chart shown in Figure 6-2 illustrates the above procedure. UP, CAL, NEXT & EDIT labels indicate keystrokes using the magnetic wand. ZERO or SPAN calibration will fail if the readings exceed built-in limits for maximum allowable zero or minimum allowable span.

NOTE: A CAL MODE INFO SCREEN IS AVAILABLE TO VIEW CERTAIN CAL MODE PARAMETERS DURING CALIBRATION. HOLD THE UP KEY FOR 5 SECONDS DURING CAL MODE TO DISPLAY THIS SCREEN.

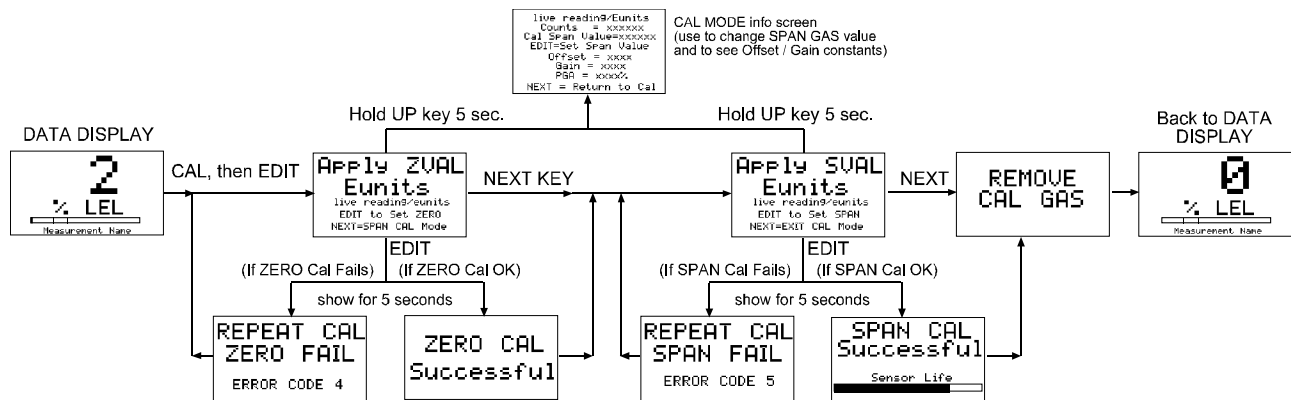

Figure 6-2: Calibration Flowchart

7 OPERATION AND MAINTENANCE

NORMAL OPERATION

During normal operation, the GDS-58XP display shows the current gas reading in direct calibrated engineering units. If the reading exceeded the pre-programmed Alarm 1 or Alarm 2 values, the front panel display LEDs will flash and the internal relays will activate. The 4-20mA output will transmit values that represent the % of scale shown on the display. If the sensor malfunctions, flow is blocked or the internal microprocessor fails the Fault LED will illuminate and the message FAULT will appear on the display screen.

The GDS-58XP utilizes a two-channel GASMAX II gas monitor to measure the gas readings and generate alarms. If a TOXIC sensor is installed on Channel 1 the flow switch is monitored by Channel 2. If a BRIDGE or GDS-IR sensor is installed on Channel 2, then the flow switch is monitored by Channel 1.

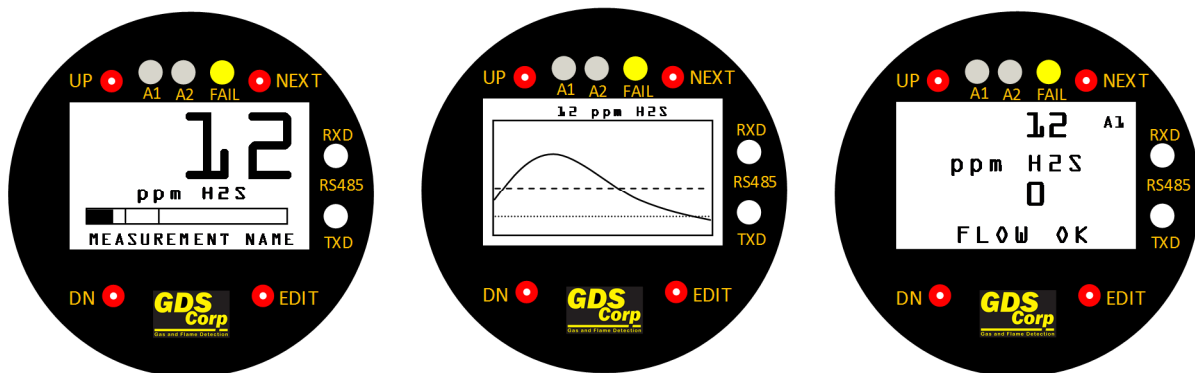

Figure 7-1: GDS-58XP Data, Trend and Dual Display

GDS-58XP DISPLAY SCREENS

The DATA display screen shows the current value in calibrated engineering units (See Fig. 7-1). A horizontal bargraph tracks the current value and shows the Alarm 1 and Alarm 2 values in graphical form. The user-programmable Engineering Units (“Eunits”) and Measurement Name text strings are shown below the real-time reading.

Above the LCD display, three LEDs indicate the status of the level and fault alarms. Note that if any relay is set for FAILSAFE operation, if LED is ON the relay will be de-energized. Relay K3 is always FAILSAFE.

To the right of the LCD display, two LEDs monitor the MODBUS RS-485 transmit (TXD) and receive (RXD) buffers. Flashing indicates sent or received data. In normal operation, RXD will flash whenever a message from the MODBUS master is received and TXD will flash when any response message is transmitted from the GDS-58XP. These only operate if a MODBUS interface is installed.

The TREND display shows a graphical representation of the most recent 30 minute trend. The Alarm 1 level is shown as a closely spaced dotted line, and the Alarm 2 level is shown as a widely spaced dashed line.

DUAL DISPLAY mode shows the data display from both channels. The display in Figure 7-1 shows a H2S sensor installed in Channel 1 and Channel 2 programmed to monitor the flow switch. As long as the flow switch is closed (flow), then Channel 2 remains at 0 and the message FLOW OK is shown. If the flow switch opens as a result of pump failure or tubing blockage Channel 2 will indicate FAULT and relay K3 will activate.

To switch between displays, use the NEXT key to sequence through the five screen options as shown in Fig. 7-6.

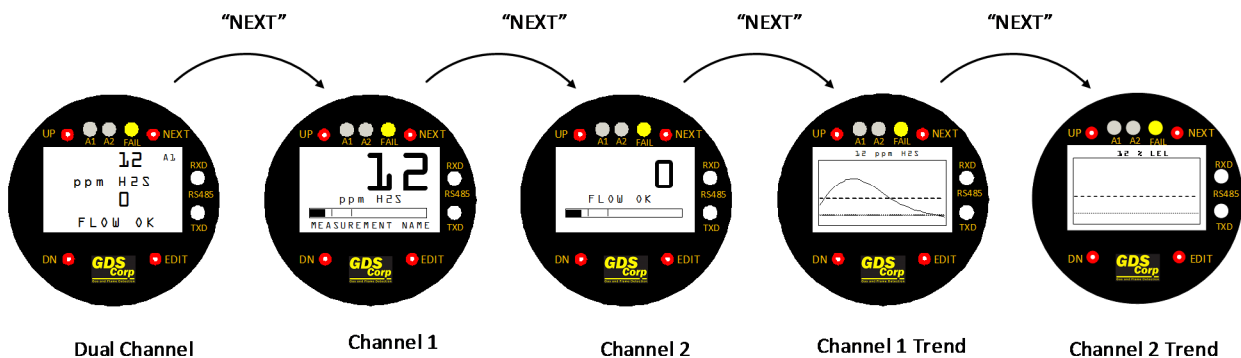

Figure 7-2: GDS-58XP Display Sequence (Toxic Sensor)

RELAY FUNCTIONALITY

Alarm relays are dry contact SPDT and may be configured as normal or FAILSAFE (“normally open held closed”). Power must be supplied from an external source and should be fused. The normally-open, common and normally-closed contact wiring layout is shown in Figure 5-5.

Relay K1 activates if the sensor channel exceeds the programmed alarm 1 threshold and cannot be acknowledged. Relay K2 activates if the sensor channel exceeds the programmed alarm 2 threshold and can be acknowledged (reset) from the front panel or via TB3 on the Relay/MODBUS board. Relay K3 indicates sensor failure and is always FAILSAFE (normally open held closed).

NOTE: THE FLOW SWITCH MONITORING CHANNEL WILL NEVER TRIGGER AN ALARM 1 OR ALARM 2

Remote Alarm Reset (TB3) can be used to acknowledge an Alarm 2 relay contact closure. Wiring from any remote pushbutton to TB3 should be shielded and protected from noise spikes to prevent false Alarm Reset commands.

SENSOR REPLACEMENT – TOXIC AND BRIDGE SENSORS

If a toxic or bridge sensor shows FAULT, does not respond to gas or can no longer be calibrated, it should be replaced. GDS-58XP sample draw systems use GDS Corp type 10-95XX toxic or bridge sensors, where the XX is the gas type (see Fig. 3-1 or Fig. 3-2). The range value should also be specified when ordering replacement sensors. For example, a replacement H₂S sensor for 0-100 ppm would be “10-9515-R0100”. To replace a GDS-58XP toxic or bridge sensor (See Fig. 7-7):

1. If necessary, declassify the area or remove power to the GDS-58XP.
2. Disconnect the sample inlet tube to the sensor flow cell.
3. Unscrew the sensor head cover and flow cell.
4. Remove the old sensor by pulling straight down.

IMPORTANT: DO NOT TRY TO UNSCREW THE SENSOR. PULL STRAIGHT DOWN!

5. Compare sensor part numbers and make sure the new sensor and old sensor match.
6. Carefully install the replacement sensor by aligning the arrow on the sensor with the arrow engraved on the sensor head. Push straight up until the sensor connector seats firmly into the sensor connector.
7. Reinstall the sensor head cover and flow cell by CAREFULLY screwing the cover onto the sensor head.

IMPORTANT: IF THE SENSOR FALLS OUT OF THE SOCKET DURING THIS STEP, IT CAN BE DAMAGED.

USE CAUTION WHEN REINSTALLING THE COVER AND FLOWCELL.

8. Apply power and allow the sensor to warm up properly (See Fig. 3-1 or Fig. 3-2) and perform a full calibration.

Local Smart Sensors are automatically recognized by the GDS-58XP and the Smart Sensor identification screen (See Fig. 7-3) should appear immediately after the installation of a local Smart Sensor.

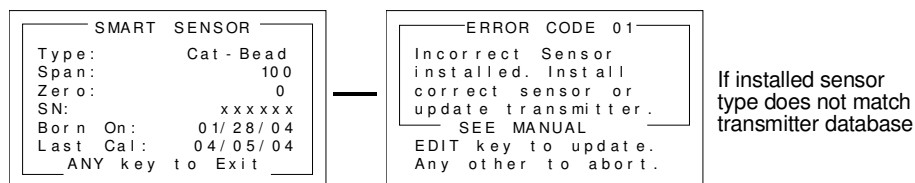
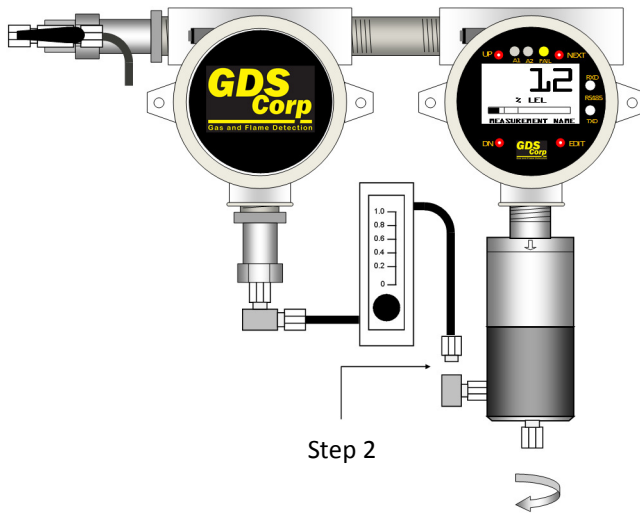

Figure 7-3: Smart Sensor Identification

If the sensor is the same gas type as was previously installed, the sensor’s calibration data will be uploaded into the GDS-58XP. All other parameters stored in the GDS-58XP will be retained.



Step 1: If necessary, declassify area or remove power

Step 2: Disconnect the sample inlet tube to the sensor flow cell

Step 3: Unscrew the sensor flow cell and sensor head cover

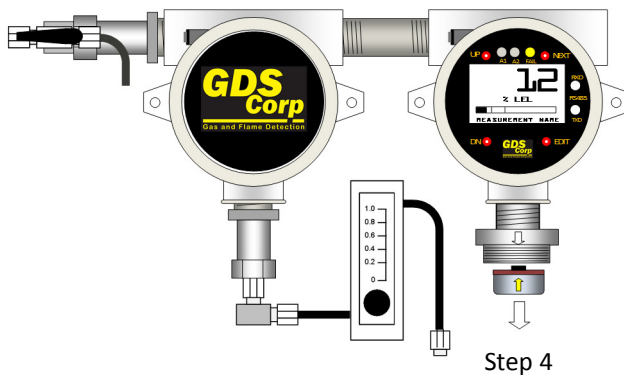

Step 4: Pulling straight down, remove the existing sensor.

Step 5: Compare the new sensor with the old sensor and verify identical part numbers

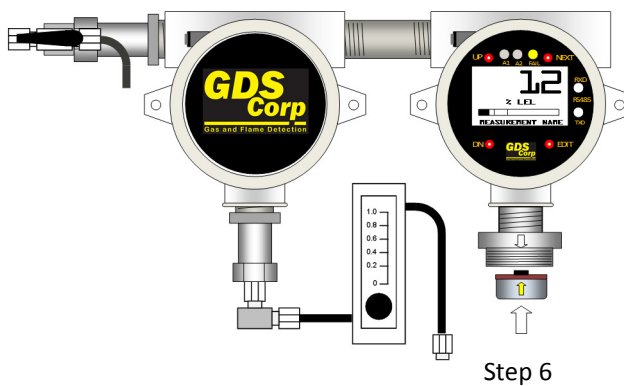

Step 6: Install the new sensor by aligning the arrow on the sensor with the arrow on the sensor head and push straight up.

Step 7: Reassemble the sensor head cover and flow cell and reattach the sample inlet tube.

Step 8: Apply power, allow the sensor to warm up and perform a complete calibration.

Figure 7-4: Sensor Replacement

NORMAL MAINTENANCE

Normal maintenance for the GDS-58XP involves verification of proper sample flow and periodic calibration using accurate gas standards. GDS Corp recommends calibration at least every three months, or more often if temperature extremes, vibration, the presence of incompatible gases or other environmental factors may accelerate the deterioration of the sensor element. Calibration should also include inspections for clogged or wet sensor heads, cracked or damaged enclosures and water incursion inside conduit or junction boxes. The sample pump is sealed and does not have any user-serviceable parts. The flow switch is sealed and does not have any user-serviceable parts.

In the event that water or other liquid enters the GDS-58XP, the flow meter and flow switch will need to be replaced or cleaned thoroughly. The flame arrestors can be cleaned and dried using compressed air or heat. The sensor should not require replacement unless the liquid level in the flow cell was excessive due to backpressure or a clogged outlet.

See Chapter 12 for a complete listing of spare parts.

8 USER MENUS

MAIN MENU

GDS-58XP setup variables are stored in non-volatile memory and can be modified by the end user to better match a particular application. The GDS-58XP Main Menu tree is shown below. To access the Main Menu, swipe the magnetic wand over the EDIT key. When in user menu display mode, use UP and DOWN to select an item, EDIT to change an item, and NEXT to exit the menu or function and return the GDS-58XP to display mode.

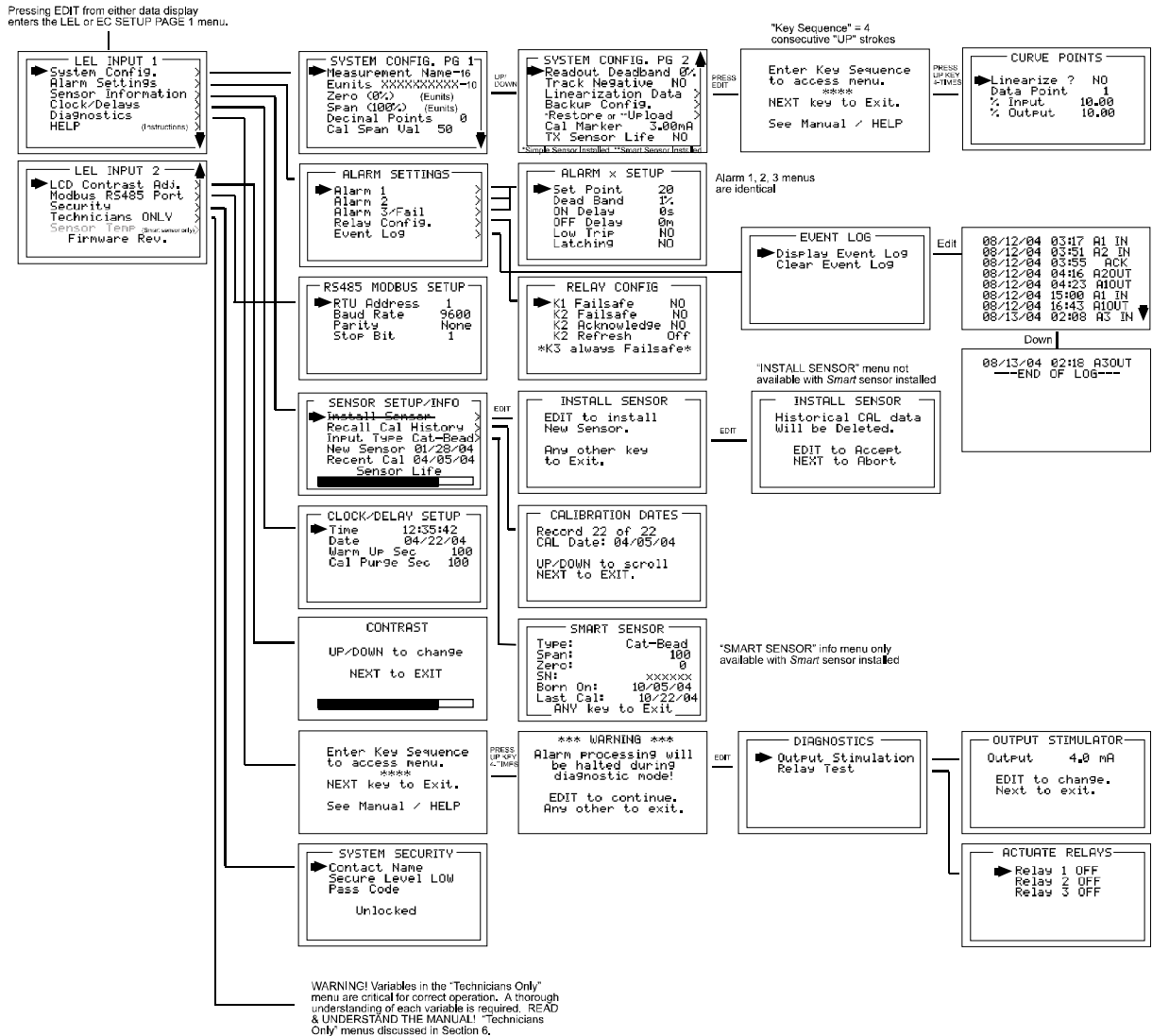

Figure 8-1: MAIN MENU FLOWCHART

SYSTEM CONFIGURATION PAGE

The System Config group consists of two pages of menus as shown in Figure 6-2. Each item's description follows in this section.

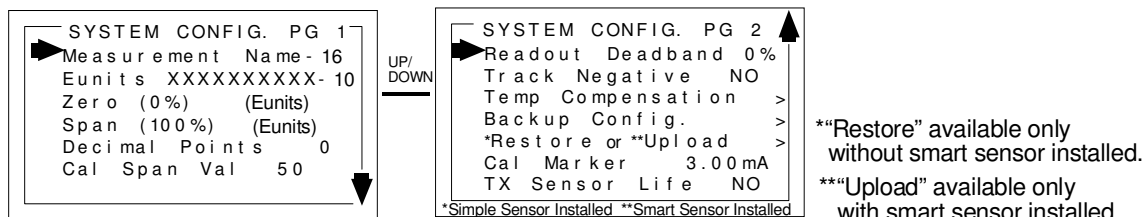

Figure 8-2: SYSTEM CONFIG MENU

MEASUREMENT NAME may be edited to contain virtually any 16-character field and is typically used to describe the monitored point by user tag number or other familiar terminology. To modify the existing setting, press the EDIT key when the cursor is pointing to the entry. Use the UP or DN keys to change the character, and the NEXT key to move to the next character. Press EDIT again when done.

EUNITS (engineering units) may have up to a 10 character ASCII field. Many common gases have pre-configured Eunits based upon the sensor type and each may be edited in this menu as described in Configuration Using the Magnetic Wand section 5-2.

ZERO (0%) defines the reading to be displayed when 4mA (0%) is the GDS-58XP output.

SPAN (100%) defines the reading to be displayed when 20mA (100%) is the GDS-58XP output. The highest reading allowed is 9999 including negative polarity sign. Polarity is only indicated for negative readings.

DECIMAL POINTS set the resolution of the LCD readings and may be set for 0, 1 or 2. For example, ZERO readings for 0, 1 & 2 decimal points displays as “0”, “0.0” & “0.00”.

CAL SPAN VALUE sets the engineering units value of the calibration gas. GDS Corp recommends that the calibration gas value be between 25% and 75% of full scale. Calibrating at 100% of scale is not recommended.

READOUT DEADBAND forces low values to continue to read zero. This is useful when there are small amounts of background gases that may cause fluctuating readouts. The highest amount of deadband allowed is 5%.

NOTE: THE 4-20MA OUTPUT IS NOT AFFECTED BY THIS SETTING.

TRACK NEGATIVE allows the display to show negative values when set to “YES”. This can be helpful when troubleshooting sensor problems. The default setting is “NO” and forces the display to read “0” if

the sensor value drops below zero. However, negative sensor outputs will always cause the Fault alarm to trip. The 4-20mA output always locks at 4mA when the reading drifts negative.

TEMP COMPENSATION adjusts sensor output based on ambient temperature. GDS Corp temperature compensated sensors are preprogrammed with the necessary table of values and are automatically uploaded to the GDS-58XP from the smart sensor. This menu item is not accessible unless a temperature compensated local Smart Sensor is installed.

BACKUP CONFIG allows users to store the entire current GDS-58XP menu database into non-volatile memory for restoration later if incorrect values are accidentally entered or uploaded.

RESTORE CONFIG restores the GDS-58XP menu database to the values from the most recent Backup Config. This menu item is only available if a smart sensor is not installed. The special keystroke sequence of 4 consecutive UP keys is also required to perform backup and restore operations.

UPLOAD SENSOR DATA allows the user to manually upload the entire smart sensor database to the GDS-58XP from the smart sensor.

CAL MARKER allows the user to set the 4-20mA output value that is transmitted during ZERO and SPAN calibration. This setting is limited to between 2ma and 20mA and is a useful way to indicate to a GDS controller that the unit is in CAL MODE.

TX SENSOR LIFE causes the GDS-58XP 4-20mA output to transmit a “sensor life” value after the completion of a successful calibration cycle. During normal operation, the GDS-58XP transmits a 4mA signal during the CAL PURGE delay to allow time for the span gas to dissipate. With TX Sensor Life = YES, the GDS-58XP transmits 4mA for the first 10 seconds, then for 5 seconds transmits a value between 4mA and 5mA, with 4mA equal to 0% sensor life and 5mA equal to 100% sensor life (see Figure 5-5). The output then returns to 4mA for the remainder of the CAL PURGE delay. For example, if after a calibration sensor life is 75%, the GDS-58XP transmits 4.75mA during the 5-second interval

NOTE: TX SENSOR LIFE SHOULD ALWAYS BE SET FOR **NO** UNLESS THE 4-20MA RECEIVER IS CAPABLE OF INTERPRETING THE SENSOR LIFE SIGNAL. MOST GDS CORP *PROTECTOR* SERIES CONTROLLERS INCLUDE THIS CAPABILITY.

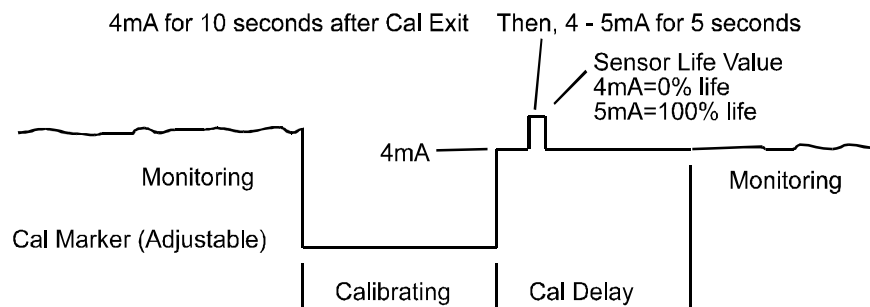

Figure 8-3: SENSOR LIFE TRANSMISSION FORMAT

ALARM SETTINGS PAGE

The Alarm Settings page covers the Alarm 1, 2, 3 Setup and Event Log menu items. Alarm 1, Alarm 2 and Alarm 3/Fail menus are identical and are therefore described only once. If the optional alarm relays are not installed, the alarm settings only affect the operation of the front panel LEDs. In that case, separate alarm settings may need to be programmed in the 4-20mA receiving device.

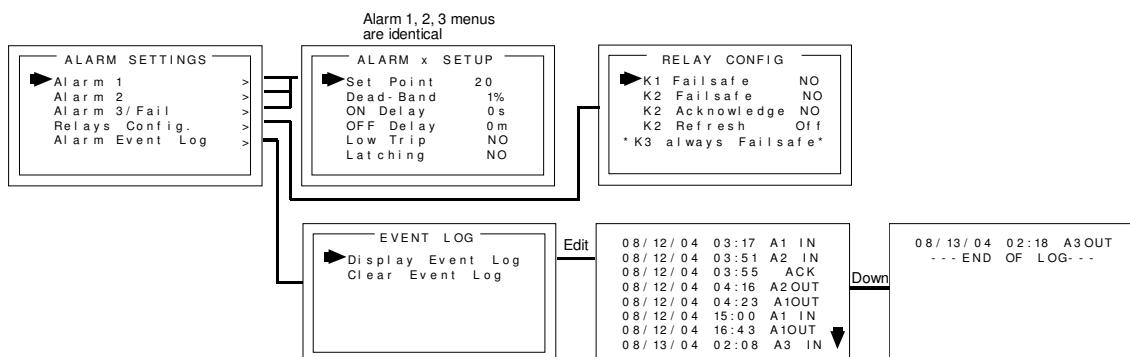

Figure 8-4: ALARM SETTINGS MENU

SET POINT enters the engineering unit value where the alarm trips. It may be negative and trip when monitored values fall out of range in this direction. A3 has a default setting of negative 10 with Low Trip set for YES. This makes it function as a FAULT alarm and trip when the monitored value falls below “-10”. It is important to adjust this value when the transmitter’s span value is set for another value other than 100. For example, a typical span setting for monitoring oxygen level is 0-25.0(%), therefore the fault level value should be adjusted to -2.5 which is equivalent to negative 10% of full scale.

DEAD-BAND has a minimum value of 1% and a maximum value of 10%. It is useful for preventing alarm cycling when the monitored value is hovering around the set point.

EXAMPLE: With a range of 0-100 ppm, if Dead-Band equals 5% and the set point is 20 ppm, after tripping at 20 ppm the value must drop below 15 ppm to reset.

ON DELAY allows entering a maximum 10 second delay before this alarm becomes active. This is useful for preventing nuisance alarms caused by brief spikes beyond the set point.

OFF DELAY allows entering a maximum 120 minute delay before clearing an alarm after the alarm condition is gone. This is useful for continuing an alarm function, such as operation of an exhaust fan, for a period of time after the alarm condition clears.

LOW TRIP set to YES causes the alarm to trip as the value falls below the set point.

LATCHING set to YES causes the alarm to remain active even after the condition is gone and only reset when the UP / RESET key is pressed from a data display.

DISPLAY EVENT LOG displays the stored events in the Event Log. These include power-on, cold-boot, alarms and alarm acknowledge events. The event log stores the date and time of the most recent 300 events.

CLEAR EVENT LOG clears the event log.

RS-485 MODBUS SETUP

The RS-485 MODBUS SETUP menu allows setting the RTU address (if RS-485 equipped) for each GASMAX on the RS-485 network. Each GASMAX must have a different RTU address when communicating on the same 2-wire cable RS-485 loop. Baud rate, Parity and Stop Bit are fixed at industry standard values of 9600 baud, No Parity and One Stop Bit.

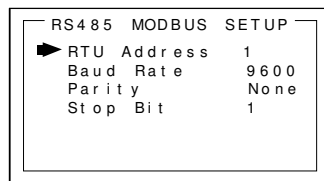

Figure 8-5: RS-485 MODBUS Setup Menu

SENSOR INFORMATION PAGE

The Sensor Information page covers settings associated with Smart or simple sensors. Users can review information contained in the Smart Sensor database, or adjust settings for remote simple sensors.

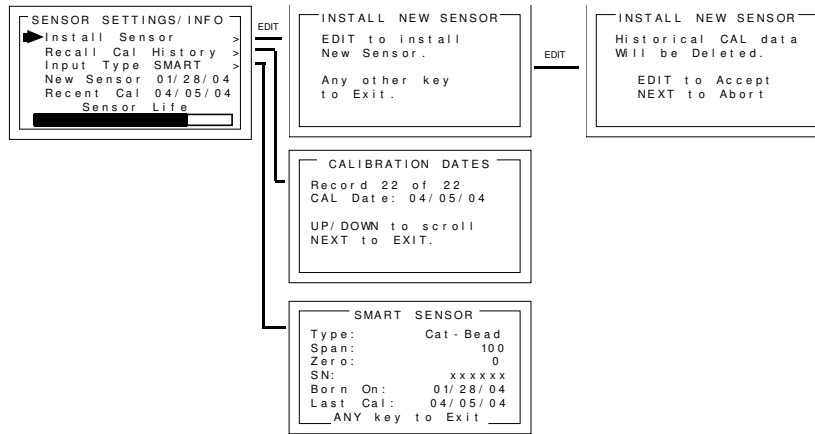

Figure 8-6: SENSOR SETTINGS MENU

INSTALL NEW SENSOR should always be performed when a new simple sensor is installed. This deletes historical CAL data and sets sensor life to 100% after initial calibration of the new simple sensor. The GDS-58XP Smart Sensor interface will automatically detect new Smart Sensors and this menu is therefore not available with a Smart Sensor connected.

RECALL CAL HISTORY recalls each successful calibration. These dates may be reviewed by scrolling with the UP / DOWN keys.

INPUT TYPE indicates what kind of input or sensor the GDS-58XP is configured to accept and is typically pre-configured at the factory. When installed, Smart Sensors upload sensor type and other data to the GDS-58XP and this data may be viewed on the SMART SENSOR information screen.

NEW SENSOR displays the date when a new sensor was last installed.

RECENT CAL displays the most recent calibration date.

CLOCK / DELAY SETUP PAGE

The GDS-58XP is equipped with a crystal-controlled, battery-backed real-time clock that maintains local Time and Date. These values are factory preset to US Central Time and should be reset to correctly match the current time zone during installation to make sure that time-stamped Event Log entries are correct.

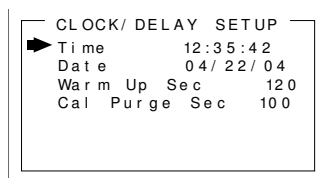

Figure 8-7: CLOCK DELAY MENU

TIME adjusts time of day in hours, minutes and seconds.

DATE adjusts date in month, day, year.

WARM UP DELAY sets the amount of time from power-on until the 4-20mA output signal begins to track the sensor output. Default setting is 60 seconds. Maximum value is 255 seconds.

CAL PURGE DELAY sets the amount of time from the completion of span calibration until the 4-20mA output signal restarts tracking the sensor output. The default setting is 60 seconds and the maximum value is 255 seconds.

LCD CONTRAST ADJUSTMENT PAGE

The LCD Contrast Adjustment allows the display to be set for optimum viewing.

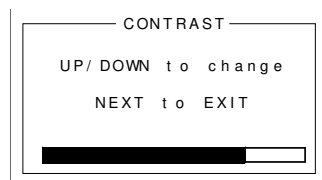

Figure 8-8: CONTRAST MENU

HELP SCREEN PAGE

The Help screen contains several pages of information describing GDS-58XP operation.

DIAGNOSTICS PAGE

The Diagnostics page provides tools for use during setup or testing. Since relays are not available on the GDS-58XP, the Relay Test option is not functional.

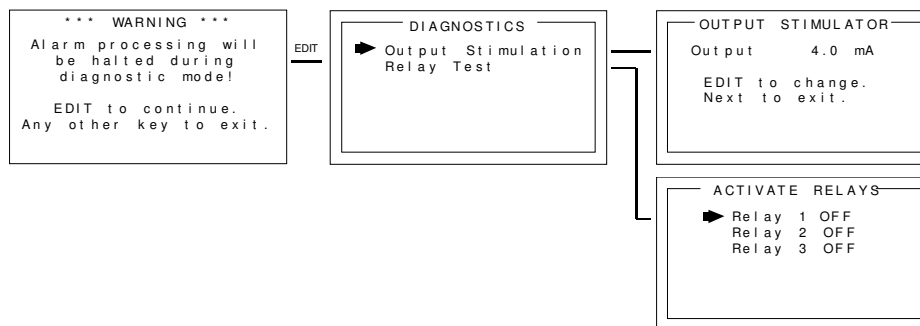

Figure 8-9: DIAGNOSTICS MENU

OUTPUT SIMULATION allows setting the 4-20mA output to virtually any desired value. This is useful for checking responses of devices receiving the GDS-58XP's 4-20mA output.

RELAY TEST allows the user to manually activate any of alarm relays independent of the presence of gas. This is useful during troubleshooting or initial installation when an end-to-end test of relay functionality must be done.

WARNING: TARGET GAS MONITORING AND ALARM PROCESSING ARE NOT ACTIVE WHILE IN THIS MENU.

SYSTEM SECURITY PAGE

The System Security menu offers two levels of protection against operation by unauthorized personnel or those with malicious intent.

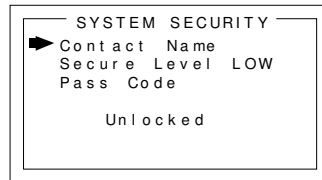

Figure 8-10: SYSTEM SECURITY MENU

CONTACT NAME is a 12 character ASCII field available for displaying a phone # or name of personal who knows the Pass Code. Lost Pass Codes may be recovered by entering the locked security menu and holding the UP key for 5 seconds. The 4-digit code appears near the bottom of the screen.

SECURE LEVEL sets LOW, HIGH or OFF modes. A LOW level allows CAL MODE sensor calibrations but requires the 4-digit Pass Code prior to altering menus. HIGH level locks the entire menu database and the CAL Mode until the correct Pass Code is entered. LOW and HIGH security levels always allow static viewing of configuration menus.

9 TECHNICIANS MENU

The TECHNICIANS MENU group consists of the XMITTER CONFIG menu and TECHNICAL PAGE menu. These menus contain items that are typically factory configured depending upon the type sensor and input connected. Care should be used when modifying these variables as some items will prevent proper operation and could endanger personnel. Access requires a special key sequence of four UP keystrokes to prevent accidental modification of critical items.

XMITTER CONFIG MENU

The XMITTER CONFIG menu is used to activate channels, precisely calibrate 4-20mA outputs and set time / date. To access the XMITTER CONFIG menu, press and hold the NEXT key for 5-seconds until the screen appears requesting the special key sequence.

WARNING: TARGET GAS MONITORING AND ALARM PROCESSING ARE NOT ACTIVE WHILE IN THIS MENU.

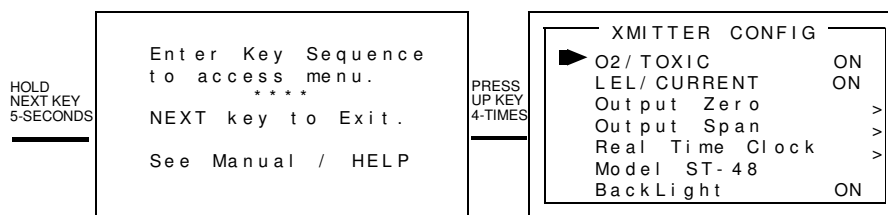

Figure 9-1: XMITTER CONFIG MENU

O2 / TOXIC when set to YES enables the Oxygen / Toxic channel (Channel 1).

LEL / CURRENT when set to YES enables the LEL / Current channel (Channel 2).

OUTPUT ZERO / SPAN TRIM provides a way to precisely set the GDS-58XP 4mA and 20mA outputs to compensate for variation in output components. These settings are programmed at the factory and should not be modified.

REAL TIME CLOCK adjusts the date and time for use in EVENT LOGGING. The current time and date can also be adjusted from the Main Menu (See Section 7).

MODEL is factory set and should not be modified.

BACKLIGHT is not available in the GDS-58XP.

TECHNICAL PAGE MENU

The TECHNICAL PAGE menu is used to adjust certain parameters associated with local or remote sensors. To access the TECHNICAL PAGE menu, enter the Main Menu, move the cursor to the second page and select Technicians Only. Enter the key sequence (four “UP” keys) to activate the TECHNICAL PAGE menu.

WARNING: TARGET GAS MONITORING AND ALARM PROCESSING ARE NOT ACTIVE WHILE IN THIS MENU.

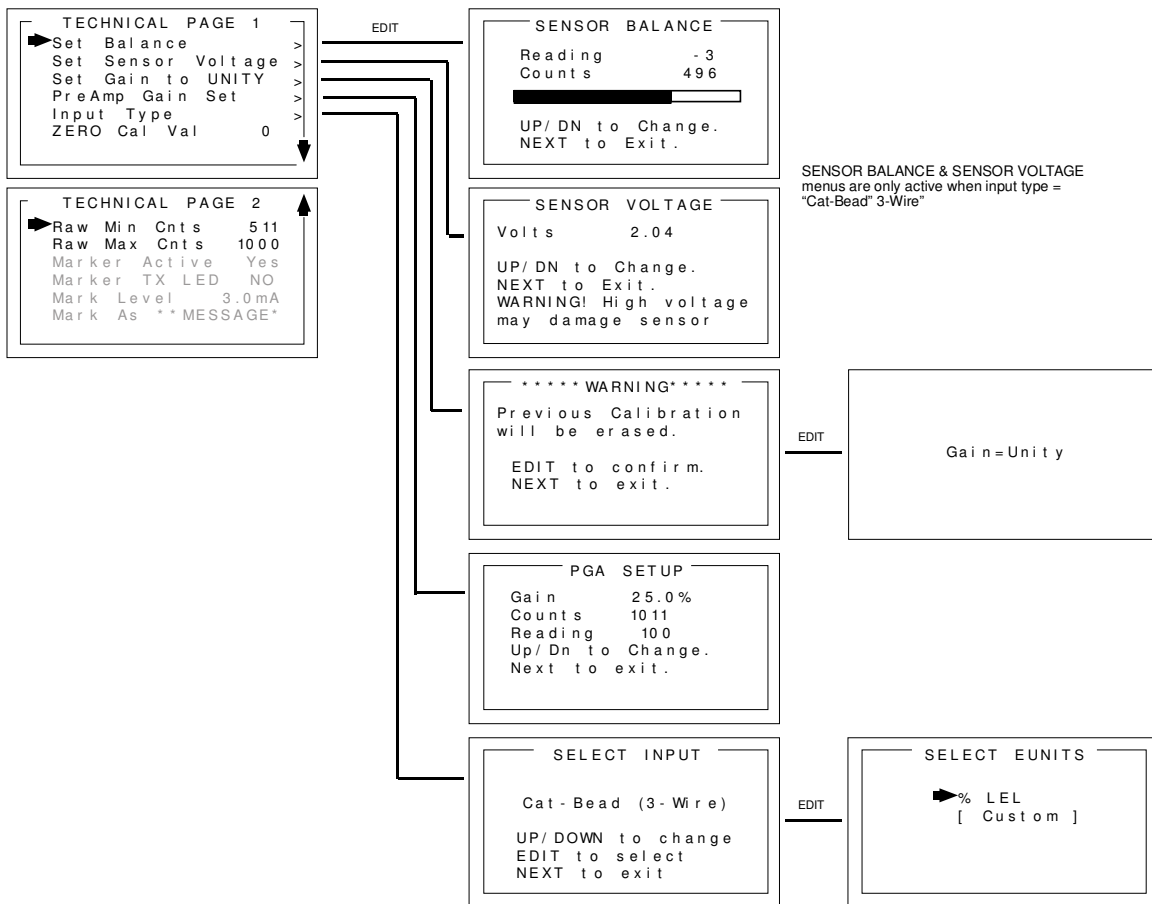

Figure 9-2: TECHNICAL PAGE MENU

SET BALANCE adjusts the balance of a bridge-type sensor and must only be performed with ZERO gas on the sensor. Balance is similar to a very coarse ZERO calibration and does not need to be precise since subsequent calibrations will correct for small errors. ZERO gas applied to the sensor should provide a Reading of -3 to +3 on the SENSOR BALANCE menu.

SET VOLTAGE adjusts the excitation voltage applied to bridge type sensors and may vary from 2 to 6 volts. Local Smart Sensors automatically adjust the excitation voltage to match the needs of the sensor.

Remote sensors require manual adjustment. Excitation voltage must be measured **at the sensor**; therefore, if the sensor is mounted some distance away from the GDS-58XP, the excitation voltage may have to be higher to compensate for losses in field wiring.

WARNING: EXCEEDING A SENSOR'S RATED EXCITATION VOLTAGE MAY DAMAGE OR DESTROY THE SENSOR.

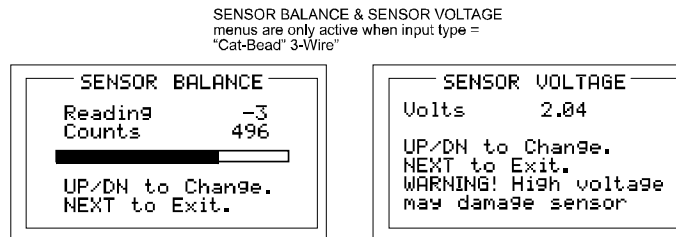

Figure 9-3: Sensor Balance & Voltage Set Menu

SET GAIN TO UNITY clears any previous calibration OFFSET and GAIN values to "0.0" and "1.0", respectively. This item is useful if a previous calibration was done in error, or if screen readings appear incorrect for no apparent reason.

WARNING: A FULL CALIBRATION SHOULD ALWAYS BE PERFORMED AFTER A SET UNITY COMMAND.

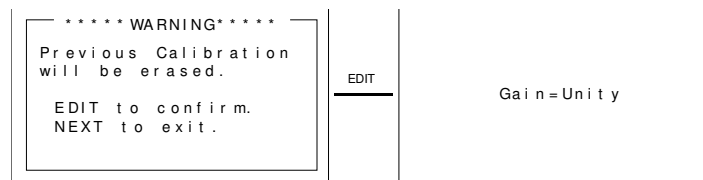

Figure 9-4: SET GAIN TO UNITY MENU

PREAMP GAIN SET allows adjustment of the analog amplifiers that match the sensor output to the optimum input range for the GDS-58XP signal conditioning circuits. Local Smart Sensors include factory-preset preamp gain values and for standard sensors and applications, these values should not be changed. For remote simple sensors or for situations where a local Smart Sensor does not quite provide enough signal to successfully complete a SPAN calibration, the Preamp gain can be adjusted using the UP / DOWN keys. GDS Corp does not recommend adjusting the Preamp Gain to any value higher than 85%.

WARNING: A FULL CALIBRATION SHOULD ALWAYS BE PERFORMED AFTER ANY CHANGE IN THE PREAMP GAIN SETTING.

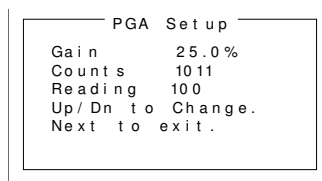

Figure 9-5: PREAMP GAIN SET MENU

Simple Sensor Input Type Local Smart Sensors automatically configure Input Type to match sensor requirements. However, when using remote sensors, Input Type must be set manually. Input Type is factory preset and should not be changed unless a different TYPE remote sensor is to be installed. Input Type configures GDS-58XP hardware to accept bridge sensors, positive coefficient electrochemical sensors, negative coefficient electrochemical sensors or 4-20 mA inputs. After selecting Input Type, a SELECT EUNITS screen indicates the default engineering units for this sensor.

Coefficient	Electrochemical Sensor Type	Default EUNITS
Negative	Hydrogen Sulfide	ppm H2S
Negative	Oxygen	% Oxygen
Negative	Carbon Monoxide	ppm CO
Negative, Bias	Ammonia	ppm NH3
Negative, Bias	Nitric Oxide	ppm NO
Negative	Ethylene Oxide	ppm Eth O2
Negative	Hydrogen Chloride	ppm HCL
Negative	Hydrazine	ppm N2H4
Negative	Arsine	ppm Arsine
Negative	Sulfur Dioxide	ppm SO2
Negative	Hydrogen	ppm H2
Negative	Hydrogen Cyanide	ppm HCN
Negative	Phosgene	ppm COCl2
Negative	Phosphine	ppm PH3
Negative	Hydrogen Fluoride	ppm HF
Positive	Nitrogen Dioxide	ppm NO2
Positive	Ozone	ppm Ozone
Positive	Chlorine	ppm Cl2

ZERO CAL VALUE should always be set to “0”.

RAW MIN / MAX COUNTS is factory preset and should not be changed.

MARKER ACTIVE enables an input level monitor on the channel 2 input if the input is set to accept a 4-20mA signal. If Marker Active is set the YES, the following actions may be programmed to occur when the input signal matches the Marker Level setting.

MARKER TX LED will cause the TX LED to illuminate if the 4-20mA input matches the Marker Level setting.

MARK LEVEL is the value at which the Marker is active. The input must be within +/- 1% of this value to be active. Setting is in mA.

MARK AS MESSAGE is a text message string that appears on the LCD when the input level matches the Marker Level setting.

10 MODBUS REGISTERS

The GDS-58XP features a full complement of user-accessible MODBUS registers that can provide a complete snapshot of each gas detectors configuration. This includes all real-time data, preset zero, span and calibration values and user-programmable text.

LIST OF GDS-58XP MODBUS VARIABLES

Variable Name	Alias	Read FC	Write FC	Notes
Ch 1 Alarm 1	2001	2	N/A	Modbus Coils (read only)
Ch 1 Alarm 2	2002	2	N/A	
Ch 1 Fault	2003	2	N/A	
Ch 2 Alarm 1	2004	2	N/A	
Ch 2 Alarm 2	2005	2	N/A	
Ch 2 Fault	2006	2	N/A	
K1 (Relay 1)	2007	2	N/A	
K2 (Relay 2)	2008	2	N/A	
K3 (Relay 3)	2009	2	N/A	
Ch 1 Cal Mode	2010	2	N/A	
Ch 2 Cal Mode	2011	2	N/A	
Alarm ACK / Reset	12001	1	5	Write TRUE to ACK; resets to FALSE
Ch 1 D2A Raw	31001	4	N/A	10 bit value; 200 = 4mA, 1000 = 20mA
Ch 2 D2A Raw	31002	4	N/A	10 bit value; 200 = 4mA, 1000 = 20mA
Ch 1 A2D Raw	31003	4	N/A	10 bit value from A/D converter
Ch 2 A2D Raw	31004	4	N/A	10 bit value from A/D converter
Ch 1 Status	31005	4	N/A	See Channel Status Word definition
Ch 2 Status	31006	4	N/A	See Channel Status Word definition
Alarm Status Word	31007	4	N/A	See Alarm Status Word definition
Transmitter Status Word	31008	4	N/A	See Transmitter Status Word definition
Ch 1 Sensor Life	31009	4	N/A	16 bit signed integer ranging from -1 to 100 where -1 indicates Cal Required
Ch 2 Sensor Life	31010	4	N/A	16 bit signed integer ranging from -1 to 100 where -1 indicates Cal Required
Ch 1 Sensor Temp	31011	4	N/A	16 bit integer from 1 to 4095 scaled for -55°C to +125°C
Ch 2 Sensor Temp	31012	4	N/A	16 bit integer from 1 to 4095 scaled for -55°C to +125°C

Ch 1 Floating Point	33001	4	N/A	See Channel Floating Point definition
CH 2 Floating Point	33002	4	N/A	See Channel Floating Point definition
Ch 1 Measurement Name	40401 - 40408	3	N/A	16 ASCII characters (2 per register)
Ch 2 Measurement Name	40409 – 40416	3	N/A	16 ASCII characters (2 per register)
Ch 1 ASCII Reading	40417 – 40419	3	N/A	6 ASCII characters (2 per register)
Ch 2 ASCII Reading	40420 – 40422	3	N/A	6 ASCII characters (2 per register)
Ch 1 EUNITS	40423 – 40427	3	N/A	10 ASCII characters (2 per register)
Ch 2 EUNITS	40428 – 40432	3	N/A	10 ASCII characters (2 per register)
Ch 1 Preamp gain	40433	3	N/A	Contact factory
Ch 2 Preamp gain	40434	3	N/A	Contact factory
Firmware Version	40435 – 40436	3	N/A	4 ASCII characters (2 per register)
Ch 1 Cal Zero Real	41001	3	N/A	Real value without decimal point
Ch 1 Cal Zero Divisor	41002	3	N/A	Divisor = 1, 10, 100 or 1000
Ch 1 Cal Span Real	41003	3	N/A	
Ch 1 Cal Span Divisor	41004	3	N/A	
Ch 1 Zero Real	41005	3	N/A	
Ch 1 Zero Divisor	41006	3	N/A	
Ch 1 Span Real	41007	3	N/A	
Ch 1 Span Divisor	41008	3	N/A	
Ch 1 Fault Real	41009	3	N/A	
Ch 1 Fault Divisor	41010	3	N/A	
Ch 1 Alarm 1 Real	41011	3	N/A	
Ch 1 Alarm 1 Divisor	41012	3	N/A	
Ch 1 Alarm 2 Real	41013	3	N/A	
Ch 1 Alarm 2 Divisor	41014	3	N/A	
Ch 1 Alarm 3 Real	41015	3	N/A	
Ch 1 Alarm 3 Divisor	41016	3	N/A	
Ch 1 Man Gain Real	41017	3	N/A	
Ch 1 Man Gain Divisor	41018	3	N/A	
Ch 1 Man Offset Real	41019	3	N/A	
Ch 1 Man Offset Divisor	41020	3	N/A	
Ch 2 Cal Zero Real	41021	3	N/A	Real value without decimal point
Ch 2 Cal Zero Divisor	41022	3	N/A	Divisor = 1, 10, 100 or 1000
Ch 2 Cal Span Real	41023	3	N/A	
Ch 2 Cal Span Divisor	41024	3	N/A	

Ch 2 Zero Real	41025	3	N/A	
Ch 2 Zero Divisor	41026	3	N/A	
Ch 2 Span Real	41027	3	N/A	
Ch 2 Span Divisor	41028	3	N/A	
Ch 2 Fault Real	41029	3	N/A	
Ch 2 Fault Divisor	41030	3	N/A	
Ch 2 Alarm 1 Real	41031	3	N/A	
Ch 2 Alarm 1 Divisor	41032	3	N/A	
Ch 2 Alarm 2 Real	41033	3	N/A	
Ch 2 Alarm 2 Divisor	41034	3	N/A	
Ch 2 Alarm 3 Real	41035	3	N/A	
Ch 2 Alarm 3 Divisor	41036	3	N/A	
Ch 2 Man Gain Real	41037	3	N/A	
Ch 2 Man Gain Divisor	41038	3	N/A	
Ch 2 Man Offset Real	41039	3	N/A	
Ch 2 Man Offset Divisor	41040	3	N/A	
Ch 1 A2D MIN	41041	3	N/A	Min and max points for A/D and D/A
Ch 1 A2D MAX	41042	3	N/A	
Ch 1 D2A MIN	41043	3	N/A	
Ch 1 D2A MAX	41044	3	N/A	
Ch 2 A2D MIN	41045	3	N/A	
Ch 2 A2D MAX	41046	3	N/A	
Ch 2 D2A MIN	41047	3	N/A	
Ch 2 D2A MAX	41048	3	N/A	

CHANNEL STATUS WORD BIT DEFINITION

Channel Status Word	Bit 0	Alarm 1 Below (1), Alarm 1 Above (0)
	Bit 1	Alarm 2 Below (1), Alarm 2 Above (0)
	Bit 2	Alarm 3 Below (1), Alarm 3 Above (0)
	Bit 3	Alarm 1 Latch (1), Alarm 1 not latch (0)
	Bit 4	Alarm 2 Latch (1), Alarm 2 not latch (0)
	Bit 5	Alarm 3 Latch (1), Alarm 3 not latch (0)
	Bit 6	Alarm 3 Active (1), Alarm 3 fault only (0)
	Bit 7	Channel Disabled (1), Channel Enabled (0)
	Bit 8	Channel in Cal (1), Channel not in Cal (0)
	Bit 9	Channel Temp Compensation (1), no temp comp (0)
	Bit 10	Fault Relay Latch (1), no fault relay latch (0)
	Bit 11	Display (Track) Negative (1), no display negative (0)

	Bit 12	Transmit Sensor Life (1), no transmit sensor life (0)
	Bit 13-15	Reserved

ALARM STATUS WORD BIT DEFINITION

Alarm Status Word	Bit 0	Ch 1 Alarm 1 (1), no alarm (0)
	Bit 1	Ch 1 Alarm 2 (1), no alarm (0)
	Bit 2	Ch 1 Fault (1), no fault (0)
	Bit 3	Reserved
	Bit 4	Ch 2 Alarm 1 (1), no alarm (0)
	Bit 5	Ch 2 Alarm 2 (1), no alarm (0)
	Bit 6	Ch 2 Fault (1), no fault (0)
	Bit 7	Reserved
	Bit 8	Relay 1 Energized (1), no relay (0)
	Bit 9	Relay 2 Energized (1), no relay (0)
	Bit 10	Relay 3 Energized (1), no relay (0)
	Bit 11-15	Reserved

TRANSMITTER STATUS WORD BIT DEFINITION

Transmitter Status Word	Bit 0	Ch 1 Active (1), Ch 1 inactive (0)
	Bit 1	Ch 2 Active (1), Ch 2 inactive (0)
	Bit 2	Secure Level (1), no security (0)
	Bit 3	Marker Tx LED (1), no marker (0)
	Bit 4-11	Reserved
	Bit 12	Relay 1 Failsafe (1), normal (0)
	Bit 13	Relay 2 Failsafe (1), normal (0)
	Bit 14	Relay 2 Acknowledge (1), normal (0)
	Bit 15	Lock (1), not locked (0)

CHANNEL FLOATING POINT DEFINITION

Channel Floating Point	15 bit plus sign 2's complement with +/-5% over / under range applied. Contact GDS Corp for more information.
------------------------	--

11 TROUBLESHOOTING GUIDELINES

TOXIC SENSOR INDICATES FAULT OR OVERRANGE

- Certain toxic sensors indicate off-scale low or high at power up and quickly drift towards zero. This is normal behavior.
- Toxic sensors showing constant FAULT: If local, remove sensor and examine for moisture or discoloration. Replace sensor if wet or discolored. If remote, check sensor cable and junction box for moisture or standing water. Remove sensor and examine for moisture or discoloration. FAULT indication generally indicates sensor useful life is exhausted.
- Toxic sensors left unpowered for more than 3 months are subject to accelerated degradation and may demonstrate a permanent loss of sensitivity.

TOXIC SENSOR WILL NOT CALIBRATE

- Sensor reading during zero calibration exceeds upper limit of zero – sensor is defective and should be replaced.
- Sensor reading during span calibration too low – sensor may be defective. However, it may be possible to temporarily continue operation by increasing PREAMP GAIN. See Section 8.2 for more details.

BRIDGE SENSOR INDICATES FAULT OR OVERRANGE

- Catalytic bead combustible sensors generally indicate off-scale high at power up and quickly drift towards zero as they reach operating temperature. This is normal behavior.
- Combustible sensors showing constant FAULT may have drifted below FAULT alarm level. Try readjusting SENSOR BALANCE to clear FAULT. If unsuccessful, replace sensor.
- Combustibles sensors showing constant OVERRANGE may have defective bead. If remote, check wiring for correct excitation voltage at sensor. Replace sensor.

BRIDGE SENSOR WILL NOT CALIBRATE

- Sensor reading during zero calibration exceeds limits – readjust SENSOR BALANCE to reset zero if possible. If not, sensor is defective and should be replaced.
- Sensor reading during span calibration too low – sensor may be defective. However, it may be possible to temporarily continue operation by increasing PREAMP GAIN. See Section 8.2 for more details.

RECEIVING DEVICE AND GDS-58XP DISPLAYED VALUES DON'T MATCH

- Check that zero and full scale range values match between GDS-58XP and receiving device (controller). Use DIAGNOSTICS menu to force GDS-58XP output to 12mA (1/2 scale) and verify appropriate half-scale reading on controller.
- Check for high impedance shorts to ground on 4-20mA wiring.
- If 4-20mA output is off-scale low or high and cannot be adjusted using DIAGNOSTICS mode, IO/Power Supply board may be defective and should be replaced.

CONTROLLER MODBUS DATA INCORRECT

- Verify that MODBUS master is requesting data from correct registers (31001 for channel 1 (toxic), 31002 for channel 2 (combustible)).
- Verify that controller MIN and MAX count settings are correct. MIN counts should be "200" which corresponds to 4mA and MAX counts should be "1000" which corresponds to 20 mA.
- Verify that the GDS-58XP MODBUS address matches the address programmed into the controller's channel configuration.

CONTROLLER SHOWING MODBUS COMM ERROR

- Check for incorrect MODBUS polarity (swap "A" and "B" if unsure; no damage will occur).
- Verify that MODBUS master is requesting data from correct MODBUS address.
- Verify that MODBUS master is requesting correct registers: 31001 for channel 1 (toxic), 31002 for channel 2 (combustible).
- Verify that there are no other MODBUS slave devices with identical MODBUS address.

GDS-58XP DISPLAY BLANK

- Verify DC power at IO/Power Supply board, TB2, terminals 1 (+24) and 4 (Gnd).
- Verify ribbon cable connected between IO/Power Supply board and Display Assembly.
- Verify that there are **no** wires connected to the 4-20mA LOOP INPUT on the back of the Display Assembly.

GDS-58XP ERROR CODES

- 01 – Incorrect sensor type – new sensor does not match most recent type of sensor. This is normal if changing sensor types. If unexpected, verify that new sensor type matches previous sensor type.
- 02 – Zero or span mismatch. Smart sensor zero or span values differ from those stored in the GDS-58XP.
- 03 – Sensor Calibration Error – Contact factory.

- 04 – Zero calibration failure – Zero readings must be within 10% of zero. For example, if the range is 0-100 ppm, the zero reading cannot be above 10 ppm. For bridge-type sensors, it may be possible to readjust the balance to restore a zero reading. Toxic sensors with high zero readings must be replaced.
- 05 – Span calibration failure – Span readings must be within a range of from ½ to 2x the target value. For example, if the target is 50 ppm, the sensor must output at least 25 ppm and no higher than 100 ppm at the current preamp gain setting for calibration to proceed.
- 06 – History data file full. Clear event log to remove.
- 07 – Sensor Channel Data CRC Fail – Error in sensor data transfer. Contact factory.
- 08 – System Data CRC Fail – Error in system data file. Contact factory.
- 09 – Custom Data CRC Fail – Error in system data file. Contact factory.
- 10- Linearization Data CRC Fail – Error in system data file. Contact factory.

12 SPARE PARTS

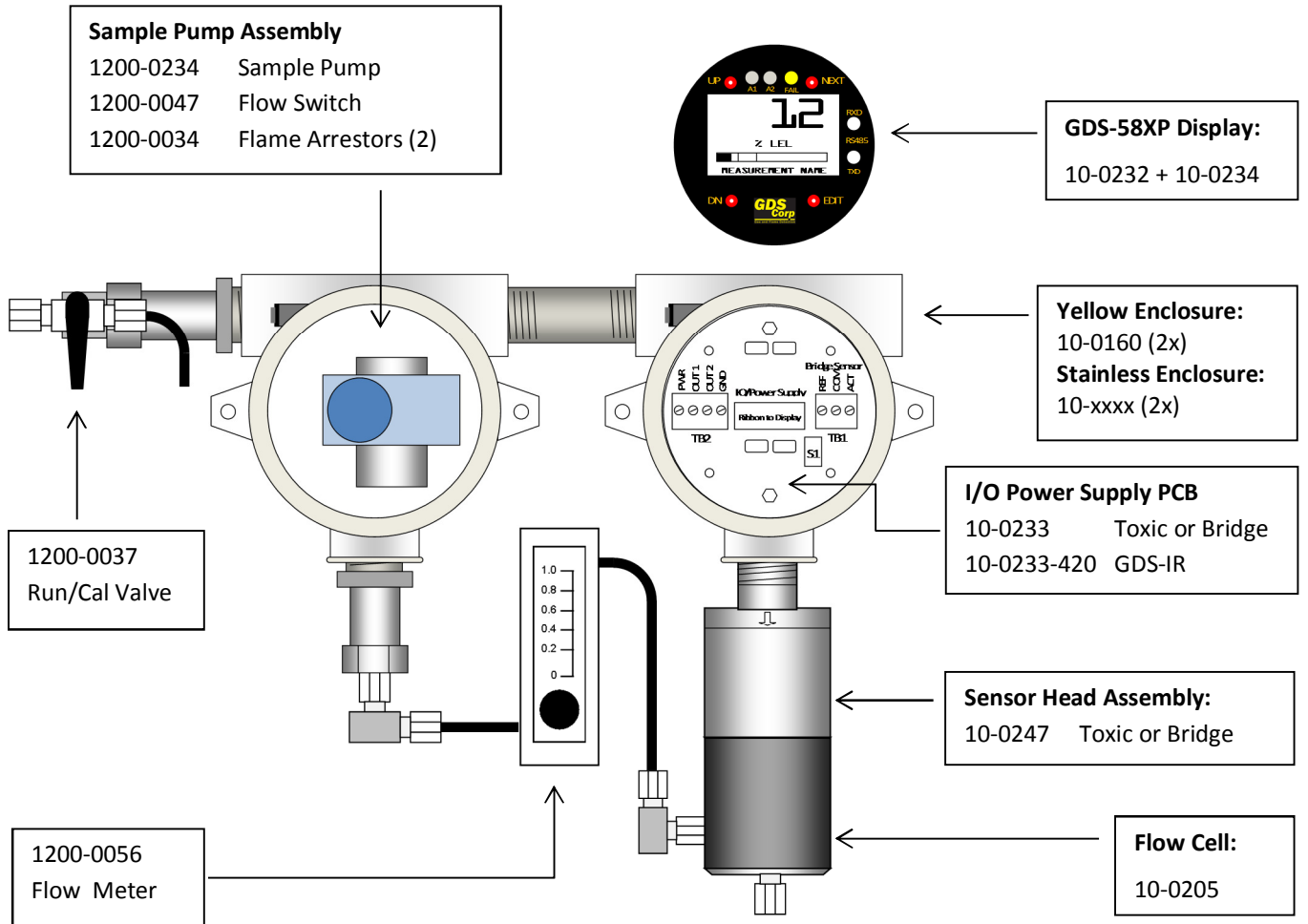

Figure 12-1: GDS-58XP Assembly with Toxic / Bridge Sensor (Spare Parts)

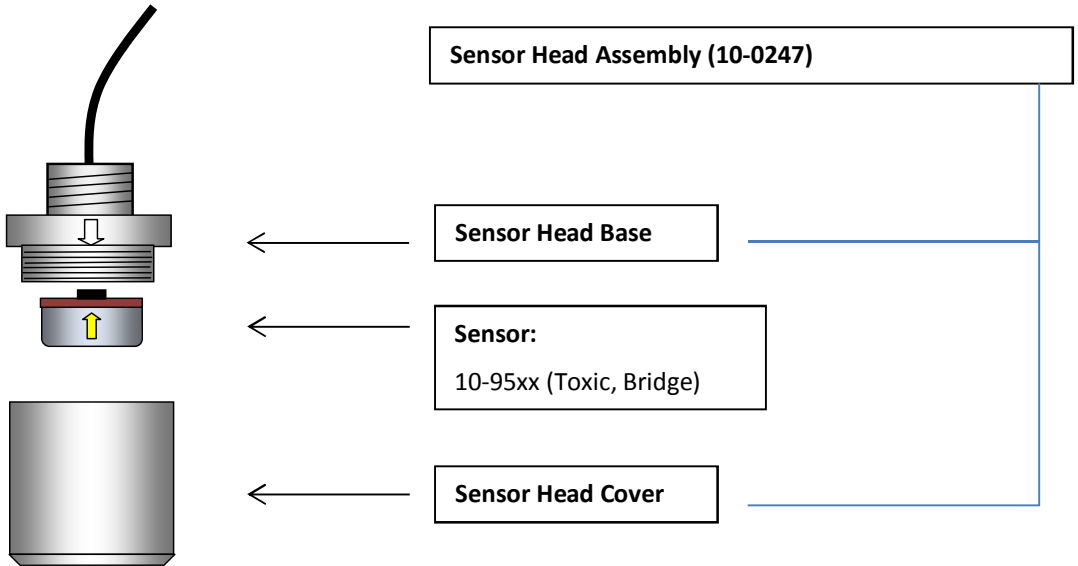

Figure 12-2: GDS-58XP Standard Sensor Head Exploded View

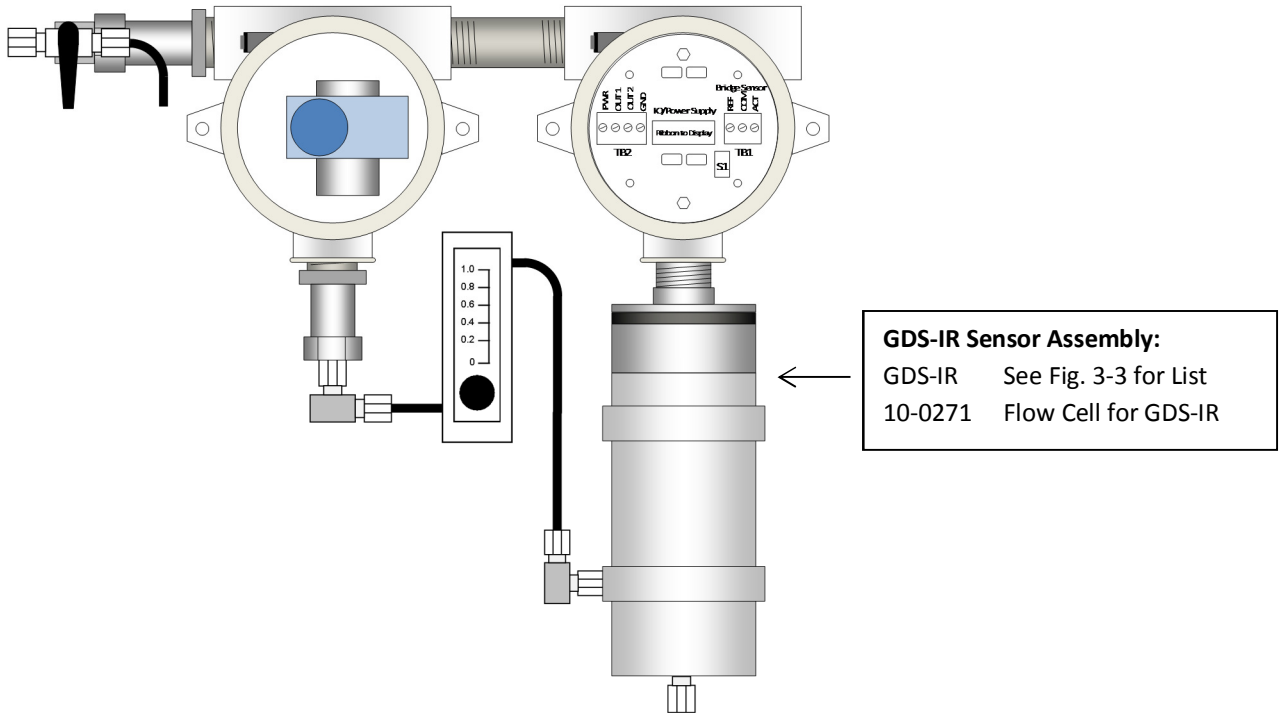

Figure 12-3: GDS-58XP Assembly with GDS-IR (Spare Parts)

13 DRAWINGS AND DIMENSIONS

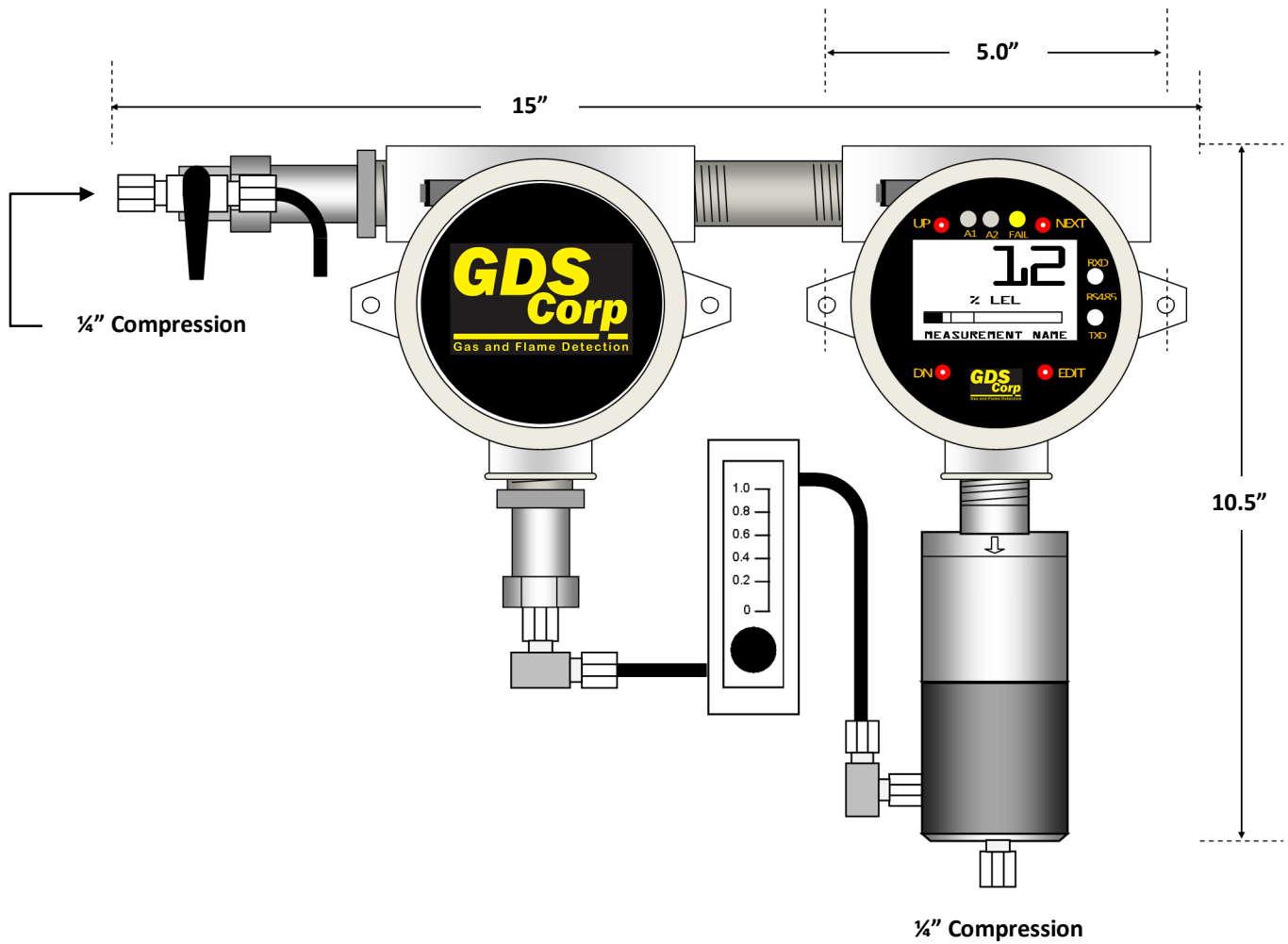

Figure 13-1: GDS-58XP Dimensions (Aluminum Enclosure)

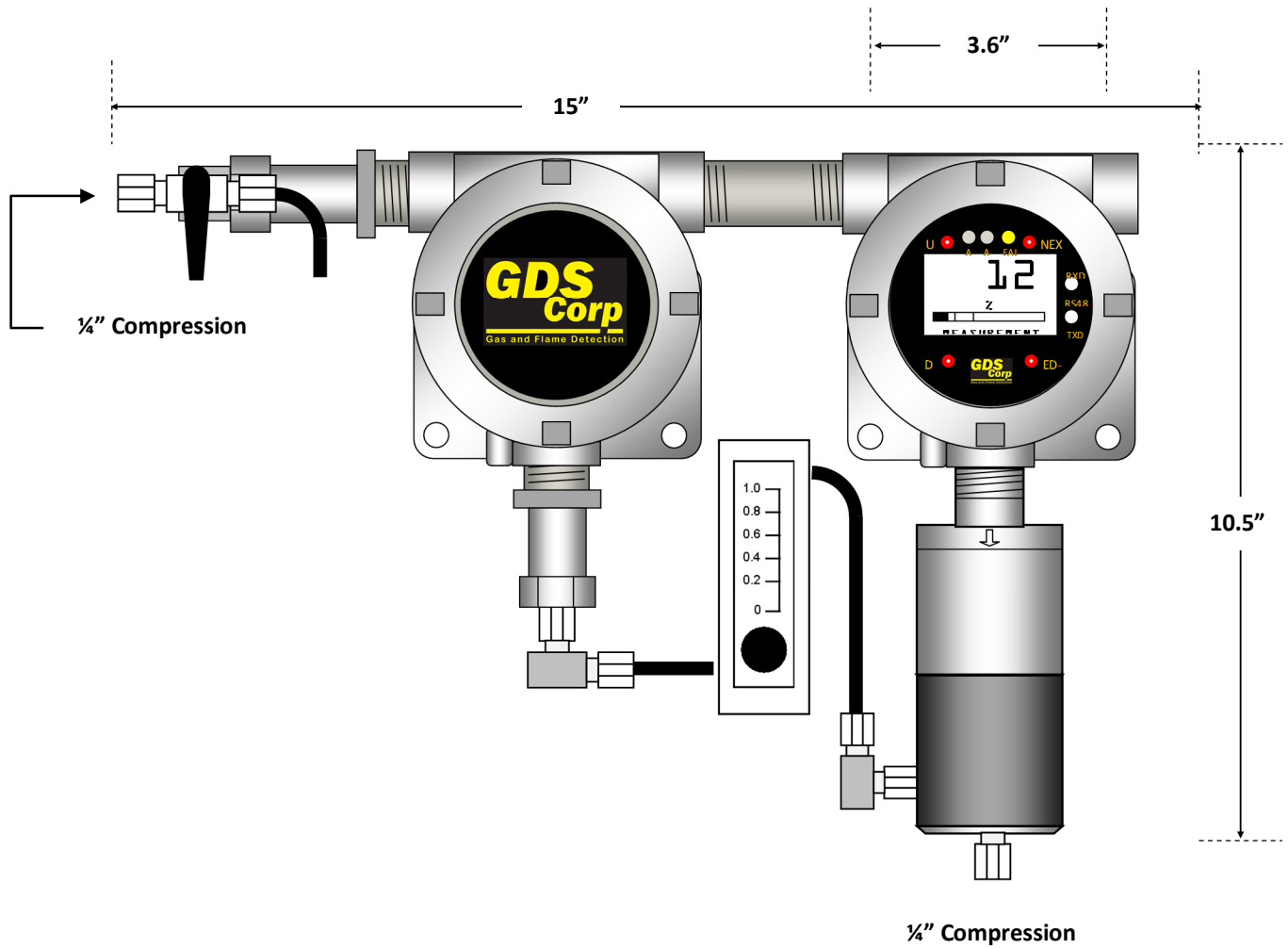

Figure 13-2: GDS-58XP Dimensions (Stainless Steel Enclosure)

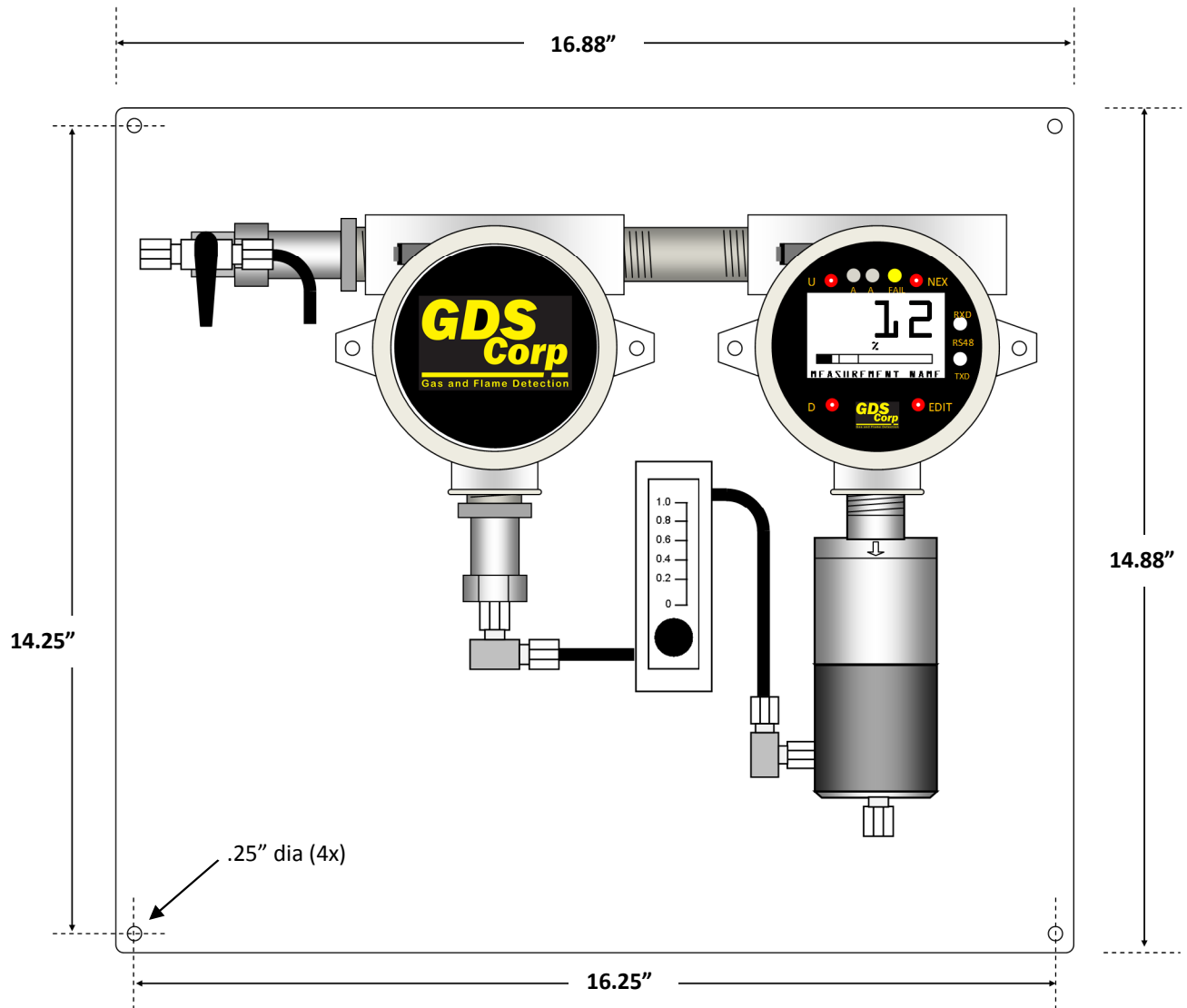

Figure 13-3: GDS-58XP 17" x 15" Mounting Plate Dimensions

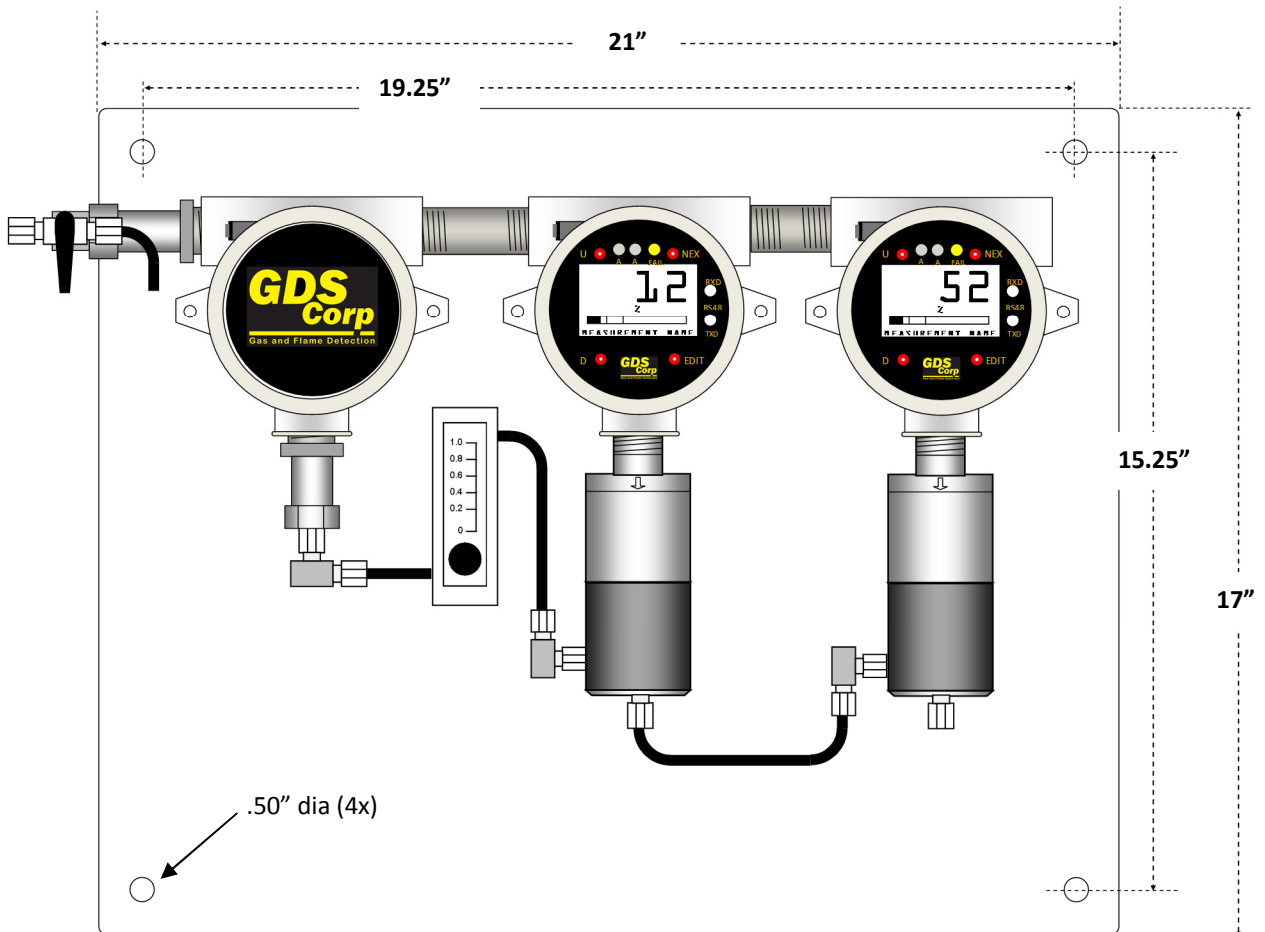

Figure 13-4: GDS-68XP 21" x 17" Mounting Plate Dimensions (AL Enclosures)

NOTE: SECOND GASMAX CAN BE REPLACED BY 110VAC POWER SUPPLY, ANALOG WIRING JUNCTION BOX OR MODBUS WIRING JUNCTION BOX

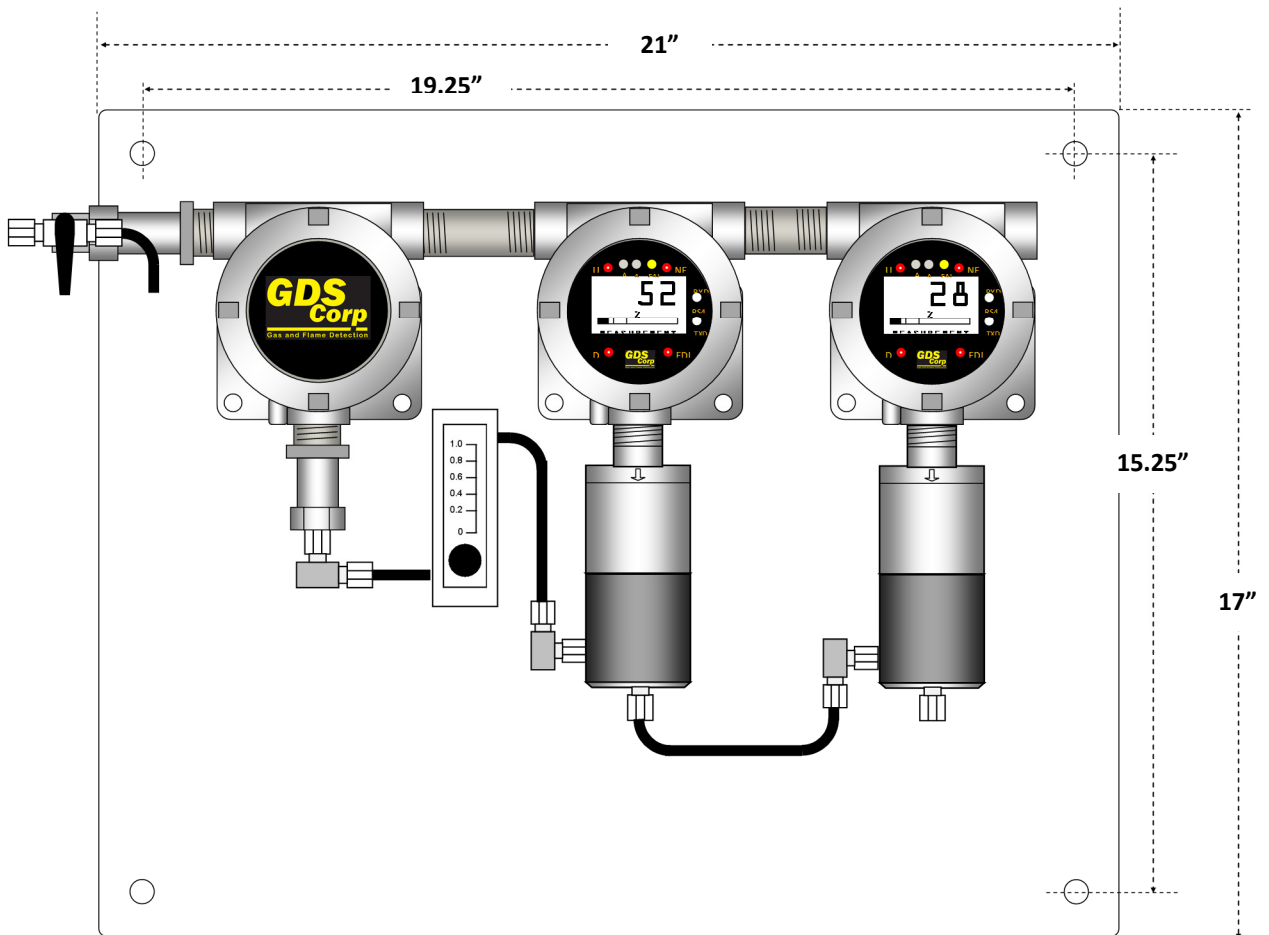

Figure 13-5: GDS-58XP 21" x 17" Mounting Plate Dimensions (SS Enclosures)

NOTE: SECOND GASMAX CAN BE REPLACED BY 110VAC POWER SUPPLY, ANALOG WIRING JUNCTION BOX OR MODBUS WIRING JUNCTION BOX

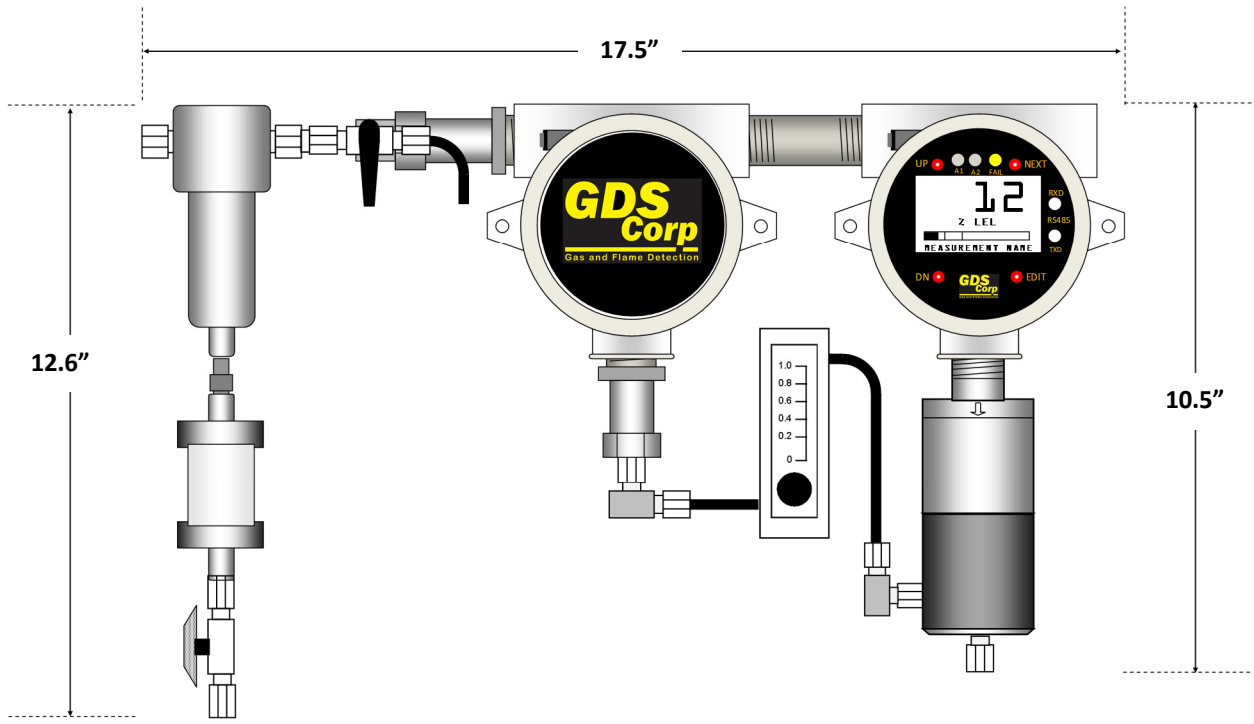

Figure 13-6: GDS-58XP with Optional Stainless Steel Coalescing Filter

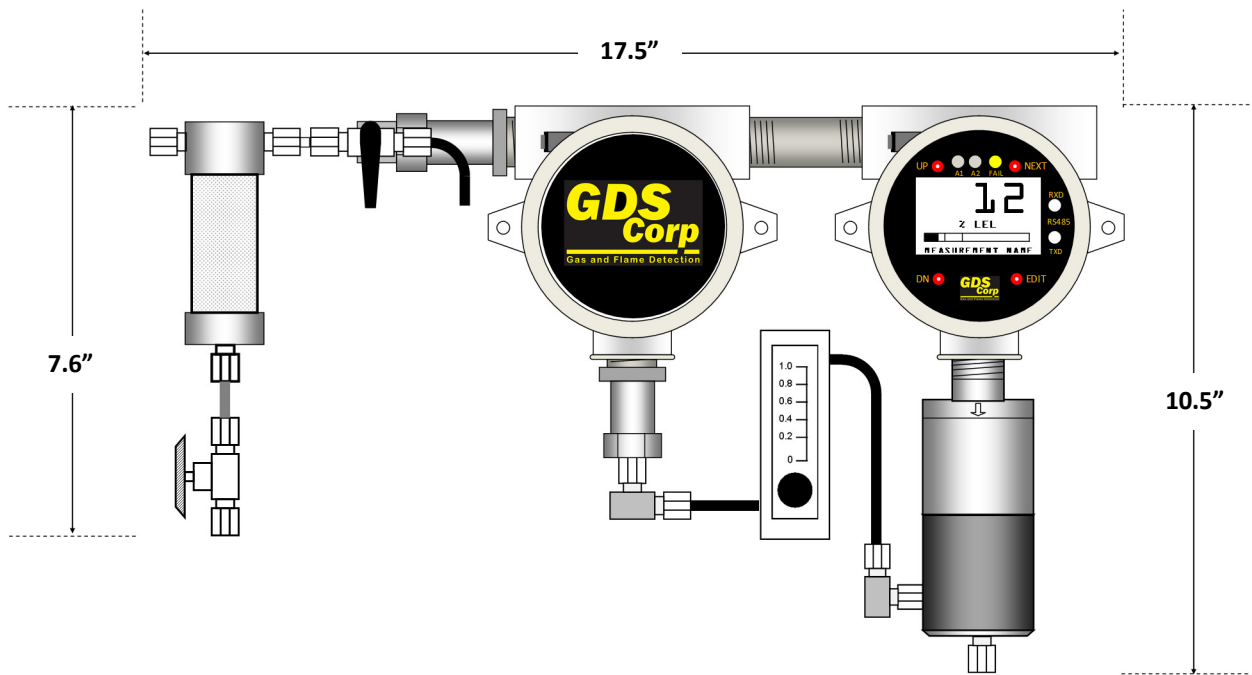

Figure 13-7: GDS-58XP with Optional Clear Coalescing Filter

14 WIRING DIAGRAMS

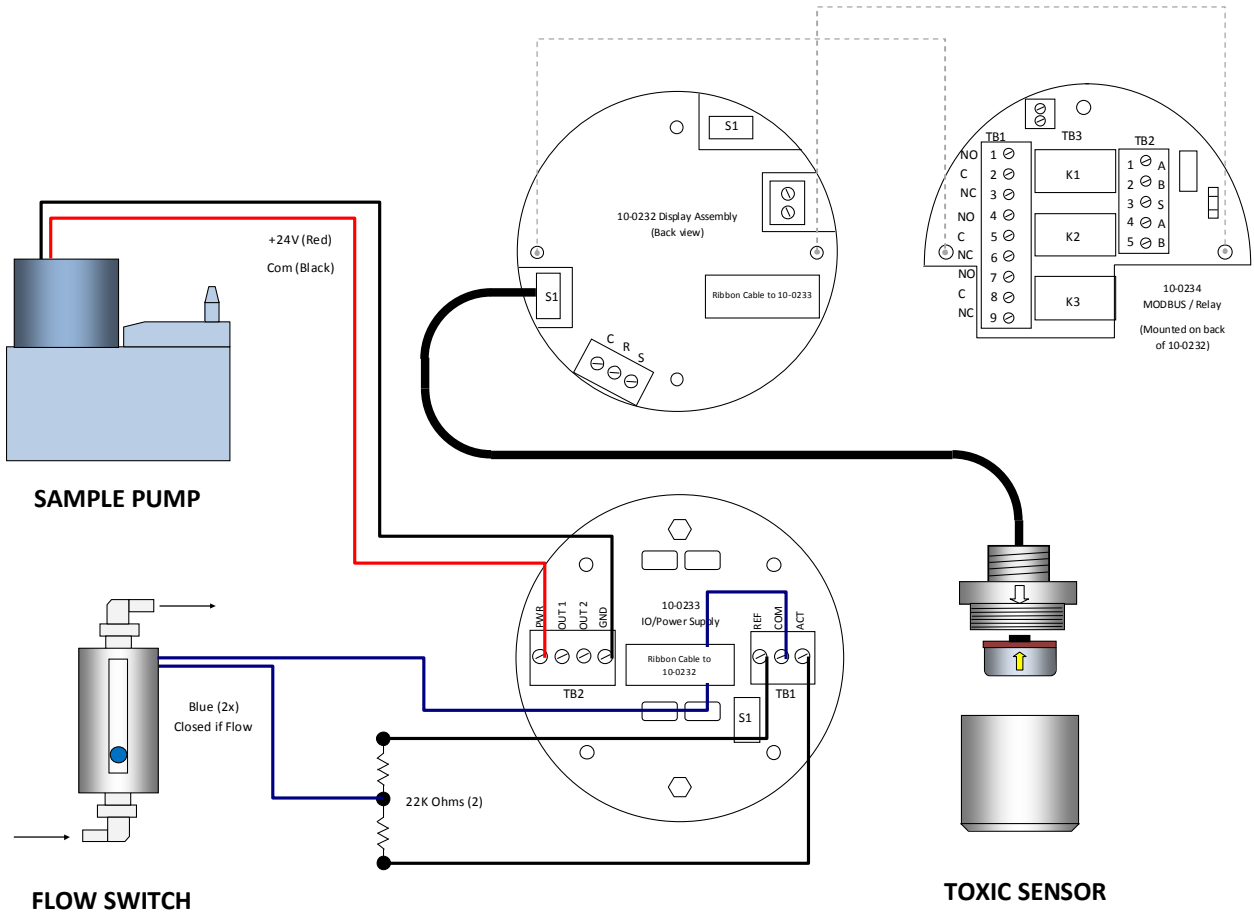

Figure 14-1: GDS-58XP Wiring Diagram (Toxic Sensor)

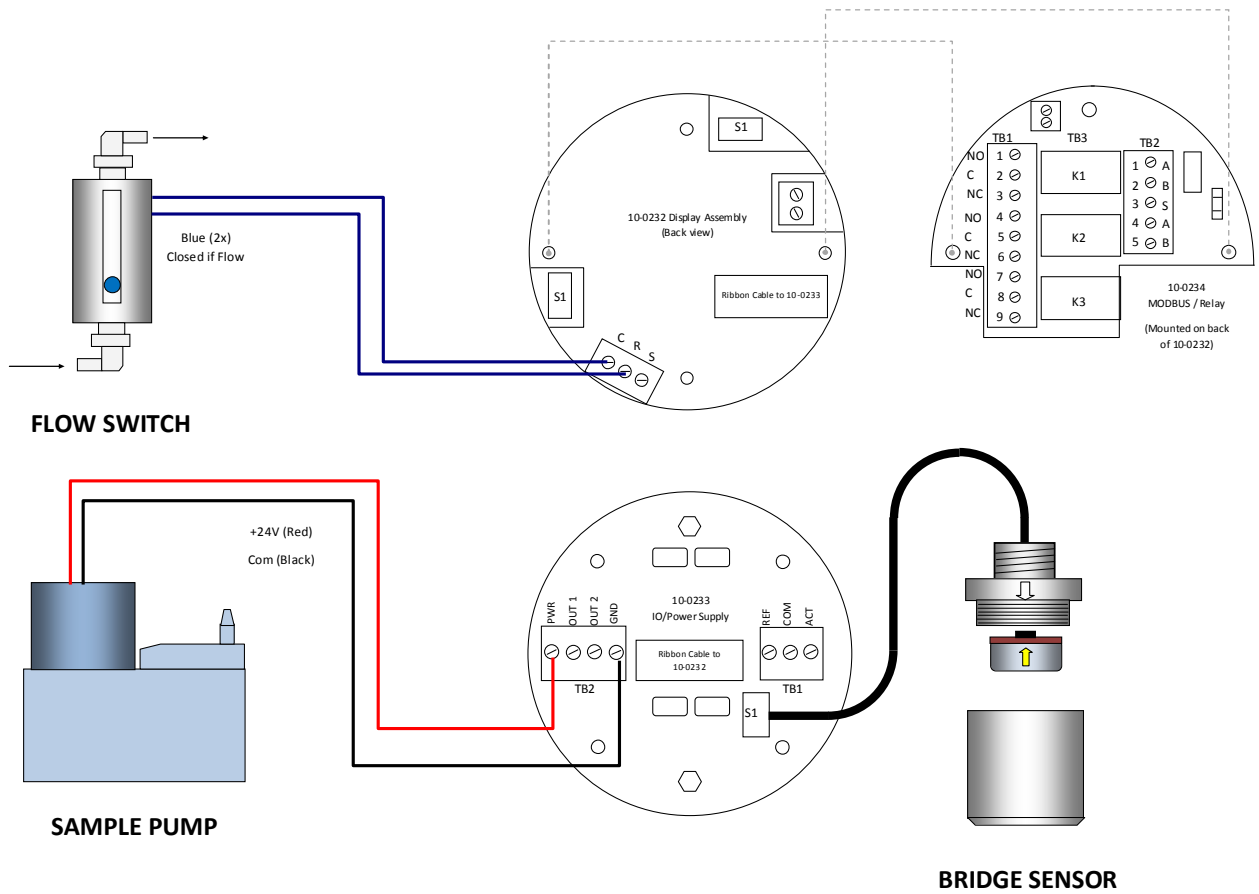

Figure 14-2: GDS-58XP Wiring Diagram (Bridge Sensor)

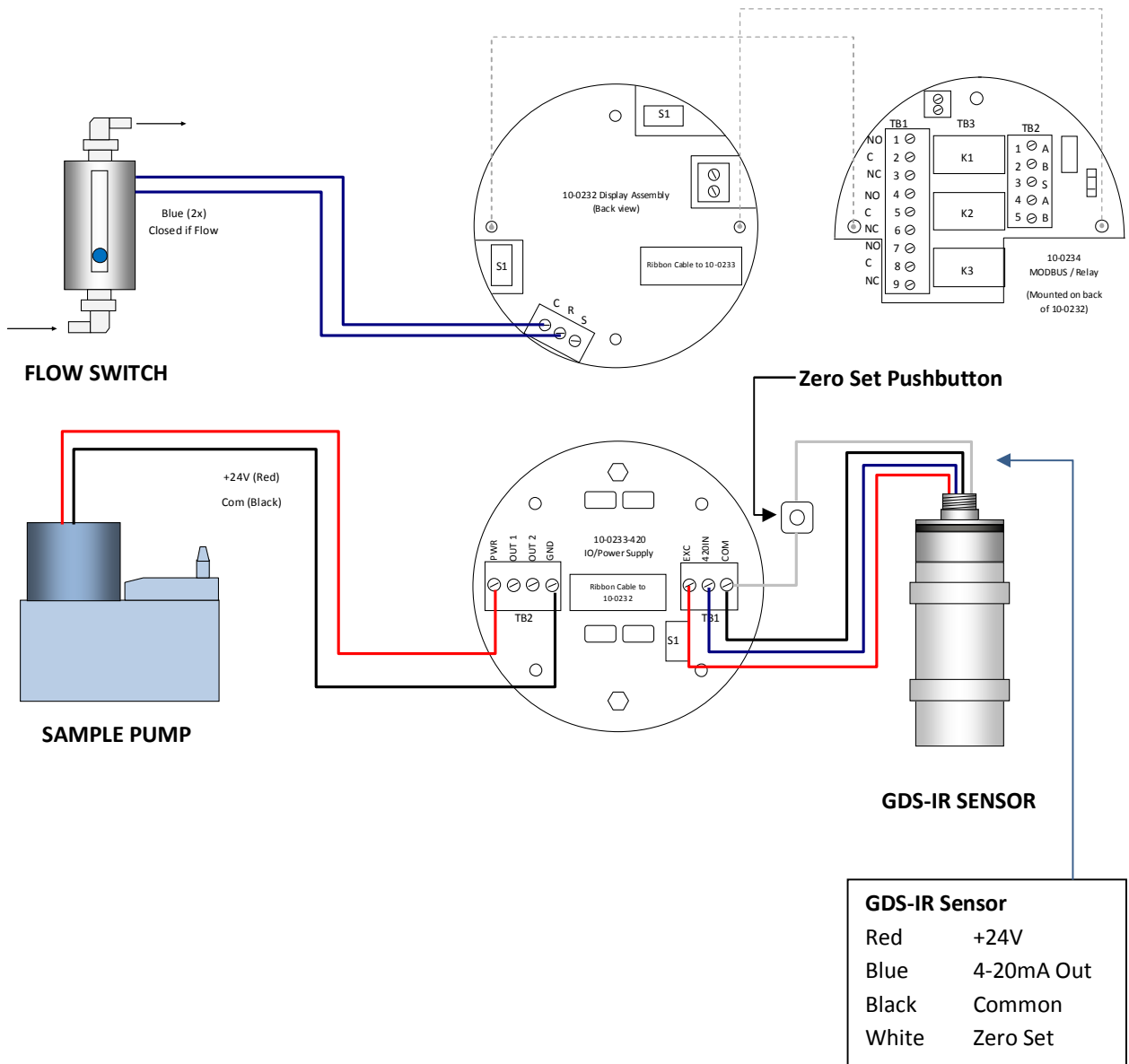

Figure 14-3: GDS-58XP Wiring Diagram (GDS-IR Sensor)

15 SAMPLE DRAW DUCT ASSEMBLY 20-0141

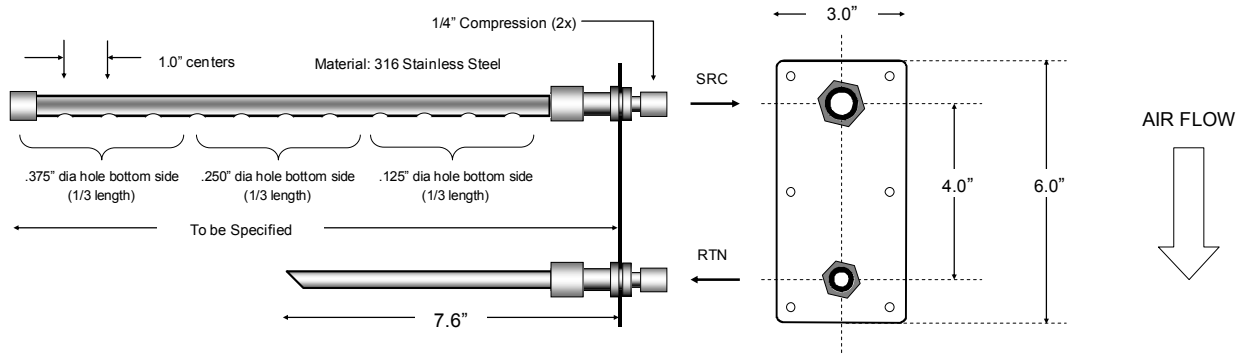

Figure 15-1: Sample Draw Duct Assembly

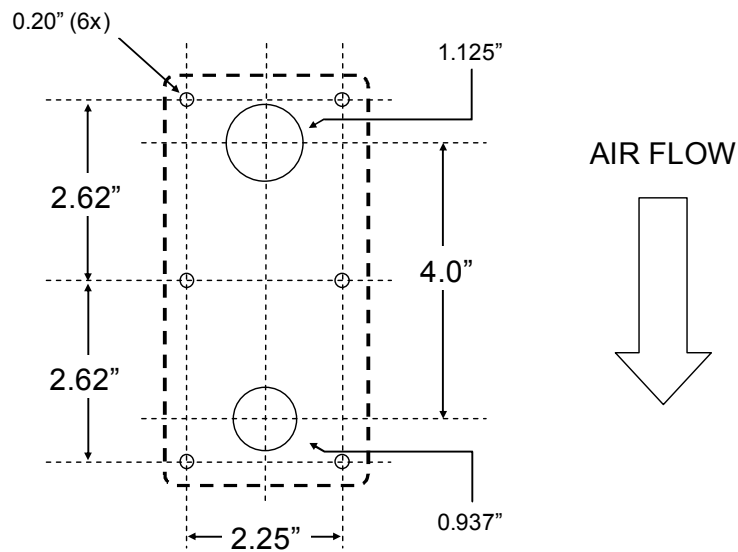

Figure 15-2: Sample Draw Duct Assembly Hole Mounting Pattern

NOTE: APPLY GASKET SEAL ON FACE OF PLATE WHEN INSTALLING SAMPLE DRAW DUCT ASSEMBLY