



Gas and Flame Detection

# Operation and Maintenance Manual

---

GASMAX/TX

Battery-Powered Dual Channel Wireless Gas Monitor

---

GDS Corp.  
1245 Butler Road • League City, TX 77573  
409-927-2980 • 409-927-4180 (Fax) • [www.gdscorp.com](http://www.gdscorp.com)

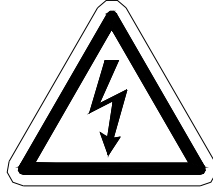

**CAUTION: FOR SAFETY REASONS THIS EQUIPMENT MUST BE OPERATED AND SERVICED BY QUALIFIED PERSONNEL ONLY. READ AND UNDERSTAND INSTRUCTION MANUAL COMPLETELY BEFORE OPERATING OR SERVICING.**

**ATTENTION: POUR DES RAISONS DE SÉCURITÉ, CET ÉQUIPEMENT DOIT ÊTRE UTILISÉ, ENTRETENU ET RÉPARÉ UNIQUEMENT PAR UN PERSONNEL QUALIFIÉ. ÉTUDIER LE MANUE D'INSTRUCTIONS EN ENTIER AVANT D'UTILISER, D'ENTRETENIR OU DE RÉPARER L'ÉQUIPEMENT.**

REVISION HISTORY

Revision 1.0 8/1/13 Initial Release (updated 11/22/13)

## CONTENTS

<b>1</b>	<b>SAFETY INFORMATION</b>	<b>8</b>
<b>2</b>	<b>GENERAL INFORMATION</b>	<b>9</b>
<b>3</b>	<b>SPECIFICATIONS</b>	<b>10</b>
<b>4</b>	<b>OPERATION</b>	<b>11</b>
<b>5</b>	<b>WIRELESS SYSTEM BASICS</b>	<b>14</b>
	System Architecture	14
	Transmission Distance	15
	Monopole and collinear Omni-Directional antennas	16
	YAGI Directional Antennas	17
	Coaxial Cables	17
	Surge Protection & Grounding	18
<b>6</b>	<b>HARDWARE OVERVIEW</b>	<b>19</b>
<b>7</b>	<b>INSTALLATION</b>	<b>21</b>
	Locating the GASMAX/TX	21
	Mounting the GASMAX/TX	21
	Power and Signal Wiring	22
	Connecting a Remote Antenna	22
	Connecting A GASMAX/TX Remote Sensor	23
	Sealing Antenna and cable Fittings	24
	Use in Hazardous Areas	24
<b>8</b>	<b>INITIAL SETUP</b>	<b>25</b>
	power-on and User Interface	25
	Setting Up the GASMAX/TX and C2/TX Wireless Site Manager	26

Initial Setup – Legacy Mode	27
<b>9 CALIBRATION</b>	<b>28</b>
Calibration Overview	28
Calibration Procedure	29
<b>10 OPERATION AND MAINTENANCE</b>	<b>31</b>
Data Display Screen	31
Trend and Dual Data Display Screens	32
Normal Operation	32
Optimizing Battery Life	33
Alarm setup	33
Sensor Replacement	34
Sensor Replacement – Remote Sensors	35
Normal Maintenance	35
<b>11 USER MENUS</b>	<b>36</b>
Channel Configuration Menu	37
Device Setup Menu	41
<b>12 TROUBLESHOOTING GUIDE</b>	<b>45</b>
Sensor Indicates Fault or Overage	45
Sensor Will Not ZERO	45
<b>GASMAX/TX EXHIBITS UNUSUAL OR UNEXPECTED BEHAVIOR</b>	<b>45</b>
GASMAX/TX Display Blank	45
GASMAX/TX and C2/TX Wireless Site Manager Displayed Values Don't Match	45
Wireless Site Manager DISPLAYs Comm Error For a Single GASMAX/TX	46
Wireless Site Manager DISPLAYs Comm Error For all GASMAX/TX	46

<b>13</b>	<b>SPARE PARTS</b>	<b>47</b>
	Display & Enclosure	47
	Sensor Head Accessories	48
	Sensor Separation Kit	48
<b>14</b>	<b>DRAWINGS AND DIMENSIONS</b>	<b>49</b>
<b>15</b>	<b>NETWORK PARAMETERS</b>	<b>50</b>

**TABLE OF FIGURES**

FIGURE 4-1: GASMAX/TX BLOCK DIAGRAM ..... 11

FIGURE 5-1: GDS CORP WIRELESS SYSTEM ARCHITECTURE ..... 14

FIGURE 5-2: RF TRANSMISSION MARGIN ..... 15

FIGURE 5-3: RF TRANSMISSION ZONE ..... 16

FIGURE 5-4: VERTICALLY POLARIZED OMNI-DIRECTIONAL AND YAGI ANTENNAS..... 17

FIGURE 6-1: GASMAX/TX WITH SINGLE LOCAL SENSOR..... 19

FIGURE 6-2: GASMAX/TX WITH DUAL SENSORS..... 20

FIGURE 6-3: P/N 10-0411 REMOTE SENSOR SEPARATION KIT ..... 20

FIGURE 7-1: GASMAX/TX I/O BATTERY BOARD ..... 22

FIGURE 7-3: CONNECTING A GASMAX/TX REMOTE SENSOR ..... 23

FIGURE 8-1: GASMAX/TX DISPLAY..... 25

FIGURE 8-2; STEP-BY-STEP SETUP CHECKLIST..... 26

FIGURE 9-1: CALIBRATION SETUP..... 29

FIGURE 9-2: CALIBRATION FLOWCHART ..... 30

FIGURE 10-1: GASMAX/TX DATA DISPLAY SCREEN ..... 31

FIGURE 10-2: DUAL DATA AND TREND DISPLAY SCREENS ..... 32

FIGURE 10-3: GASMAX/TX SENSOR REPLACEMENT ..... 34

FIGURE 11-1: GASMAX/TX MAIN MENU TREE ..... 36

FIGURE 11-2: CHANNEL CONFIGURATION MENU ..... 37

FIGURE 11-3: ALARM SETTINGS MENU ..... 38

FIGURE 11-4: SMART SENSOR INFORMATION MENU ..... 39

FIGURE 11-5: TECHNICIANS MENU..... 39

FIGURE 11-6: SET UNITY GAIN MENU..... 40

FIGURE 11-7: PREAMP GAIN SET MENU..... 40

FIGURE 11-8: RF LINK TEST MENU..... 41

FIGURE 11-9: RADIO SETUP MENU (2.4 GHZ)..... 41

FIGURE 11-10: CLOCK / DELAY MENU ..... 42

FIGURE 11-11: SECURITY MENU ..... 43

FIGURE 11-12: LCD CONTRAST MENU ..... 43

FIGURE 11-13: POWER OFF MENU ..... 44

FIGURE 13-1: GASMAX/TX + LOCAL SENSOR SPARE PARTS..... 47

FIGURE 13-2: GASMAX SENSOR HEAD SPLASH GUARD& FLOW CELL ..... 48

FIGURE 13-3: GASMAX/TX REMOTE SENSOR SEPARATION KIT.....	48
FIGURE 14-1: GASMAX/TX DIMENSIONS (SINGLE LOCAL SENSOR).....	49
FIGURE 15-1: GDS CORP NETWORK IDENTIFIERS.....	50

# 1 SAFETY INFORMATION

## Important – Read Before Installation

Users should have a detailed understanding of GASMAX/TX operating and maintenance instructions. Use the GASMAX/TX only as specified in this manual or detection of gases and the resulting protection provided may be impaired. Read the following WARNINGS prior to use.

### WARNINGS

- The GASMAX/TX gas monitor described in this manual must be installed, operated and maintained in accordance with information contained herein. Installation in any hazardous area must comply with all applicable restrictions, requirements and guidelines for said hazardous areas. It is the end user customer's final decision to ensure that the GASMAX/TX is suitable for the intended use.
- The GASMAX/TX is designed and constructed to measure the level of certain gases in ambient air. Accuracy in atmospheres containing steam or inert gases cannot be guaranteed.
- Always mount the sensor head vertically with the sensor head facing down.
- Do not paint transmitter or sensor assembly.
- Do not operate the GASMAX/TX if its enclosure is damaged or cracked or has missing components. Make sure the cover, internal PCB's and field wiring are securely in place before applying power.
- Do not expose the GASMAX/TX to electrical shock or continuous severe mechanical shock. Protect the GASMAX/TX and related sensor assemblies from dripping liquids and high power sprays.
- Calibrate with known target gas at start-up and check on a regular schedule, at least every 90 days. More frequent inspections are encouraged to spot problems such as dirt, oil, paint, grease or other foreign materials on the sensor head.
- Periodically test for correct operation of the system's alarm events by exposing the monitor to a targeted gas concentration above the High Alarm set point.
- Use only for applications described within this manual.

## 2 GENERAL INFORMATION

The GDS Corp GASMAX/TX Wireless Gas Monitor and matching C2/TX Wireless Site Manager work together seamlessly to deliver highly reliable, cost effective, customer-friendly solutions for wireless gas detection. The GASMAX/TX can also be used in 'legacy mode' with existing GDS Corp Wireless Controller / Receivers such as the C1 Protector, C64 Protector or C2 Quad Protector Controller / Receiver.

The GASMAX/TX supports one or two local or remote sensors for toxic gases, carbon dioxide or hydrocarbon combustibles. The advanced microcontroller, non-intrusive magnetic interface and superior graphic LCD display offers rapid setup, simplified operation and enhanced diagnostics not found in previous generation products.

The GASMAX/TX's tightly integrated radio modem utilizes frequency hopping spread spectrum (FHSS) technology to provide reliable transmission of gas concentration data and detector status across long distances while using very little power. Battery life can be as long as one year under common circumstances. Instead of complicated setup procedures that involve channel selection and identification codes, the GASMAX/TX is configured using a single network identifier letter and single device number. When configured as part of a system with a third-generation C2/TX Wireless Site Manager, all configuration and setup information programmed into the GASMAX/TX is automatically transmitted to the C2/TX Wireless Site Manager, eliminating redundant setup and minimizing programming errors.



### Key features:

- Single or dual channel, toxic and/or combustible using new Ultra-Low-Power Infrared for Combustibles and Carbon Dioxide
- Six to 12 month battery life on one replaceable 3.6VDC Lithium battery
- Tightly integrated 900MHz or 2.4 GHz radios with Frequency Hopping Spread Spectrum (FHSS) for maximum range
- Automatic sensor recognition and setup with GDS Corp Smart Sensors
- Large LCD shows values, bar-graph and RF interface
- User-prompted calibration procedure
- Power on / Power off using magnetic wand – no need to open the enclosure
- Suitable for use in Class I Division 1 Hazardous Areas with XP rated antenna coupler

### 3 SPECIFICATIONS

Power	Disposable 3.6v Lithium-Ion battery (D-size)
Display	64 x128 pixel LCD with engineering units, bargraph and 30-minute trend
Ch 1 Input	Digital input from local or remote type 10-97xx toxic or infrared sensors
Ch 2 Input	Digital input from local or remote type 10-97xx toxic or infrared sensors
Accuracy	+/- 5% of full scale (typical) over temperate range
Output	Gas concentration represented by a wirelessly transmitted numeric value between 800 counts (0% of scale) and 4000 counts (100% of scale); one data value per channel. Alarm status bits and battery voltage information is also transmitted.
RF Section (900 MHz)	User adjustable transmit power from 10 mW ( ) to 1.0 watt (+30 dBm); frequency range from 902 to 928 MHz. Beacon receiver sensitivity -100 dBm
RF Section (2.4 GHz)	Fixed transmit power of 50 mW. Frequency range from 2.406 GHz to 2.435 GHz (network identifier A – R) and from 2.444 GHz to 2.472 GHz (network identifier S – Z)
Temperature	-40°C to +55°C
Memory	On-board non-volatile memory retains all user settings
Housing	Aluminum housing with epoxy paint standard; #316 stainless steel optional
Dimensions	Width 5.4" (137 mm), Height 8" (203 mm), Depth 5" (127 mm) Shipping wt. 6.5 lbs. (3 kg)
Approvals	Enclosure CSA certified for Class I Division 1 hazardous areas
Warranty	Two years on electronics, one year on sensor

AVAILABLE SENSORS AND RANGES					
P/N	Sensor	Range	P/N	Sensor	Range
10-9750	Methane	0-100% LEL	10-9753	Carbon Dioxide	0-100%
10-9751	Propane	0-100% LEL			
10-9710	Oxygen	0-25%	10-9722	Ethylene Oxide	0-100 ppm
10-9711	Carbon Monoxide	0-300 ppm	10-9723	Arsine	0-1 ppm
10-9712	Chlorine	0-10 ppm	10-9724	Silane	0-50 ppm
10-9713	Chlorine Dioxide	0-1 ppm	10-9725	Fluorine	0-1 ppm
10-9714	Hydrogen	0-4%	10-9726	Phosgene	0-1 ppm
10-9715	Hydrogen Sulfide	0-9999 ppm	10-9727	Hydrazine	0-1 ppm
10-9716	Hydrogen Cyanide	0-30 ppm	10-9728	Nitric Oxide	0-50 ppm
10-9717	Hydrogen Chloride	0-30 ppm	10-9729	Nitrogen Dioxide	0-100 ppm
10-9718	Hydrogen Fluoride	0-5 ppm	10-9730	Mercaptan	0-50 mg/m3
10-9719	Sulfur Dioxide	0-500 ppm	10-9731	Tetrahydrothiophene	0-50 mg/m3
10-9720	Ammonia	0-1000 ppm	10-9732	Diborane	0-1 ppm
10-9721	Ozone	0-1 ppm	10-9733	Hydrogen Sulfide Low RH	0-100 ppm

## 4 OPERATION

The GASMAX/TX wireless gas monitor is designed to detect dangerous levels of toxic or hydrocarbon combustible gases and transmit that information to a GDS Corp remote site manager or controller / receiver.

The GASMAX/TX uses the new highly integrated 10-97xx series ultra-low-power infrared or zero power electrochemical Smart Sensors that allow each sensor to be individually optimized for the target gas, range and environmental conditions.

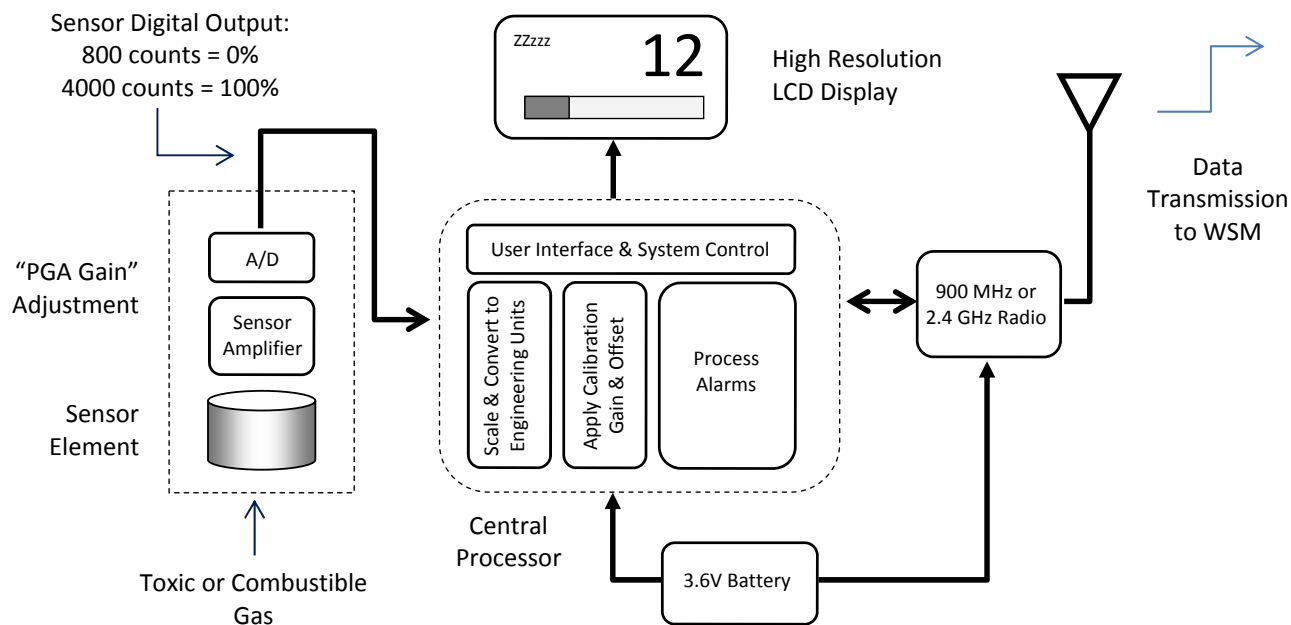

**Figure 4-1: GASMAX/TX Block Diagram**

Toxic gases entering the sensor head react with the electrolyte in the sensor to produce a small electrical output signal. Electronics on the sensor board amplify the signal (“PGA Gain”) and convert the information from analog to digital using a 12-bit A/D converter. If an ultra-low-power infrared sensor is being used, hydrocarbon gases enter the sensor and block the passage of infrared light from the IR source to the detector. An integrated microprocessor in the infrared sensor linearizes the value and converts the output to digital.

**IMPORTANT: TOXIC SENSORS ARE SUBJECT TO ACCELERATED DETERIORATION IF POWER IS NOT APPLIED WITHIN 3 MONTHS OF SHIPMENT FROM GDS CORP.**

**IMPORTANT: THE GASMAX/TX INFRARED SENSOR WILL NOT DETECT COMBUSTIBLE LEVELS OF HYDROGEN GAS.**

Every six seconds, the GASMAX/TX central processor wakes up, reads the sensor's digital output, scales and converts the reading to engineering units, applies correction factors based on the most recent calibration and displays the value on the LCD display. Based on the gas concentration level and alarm levels programmed by the user, the microprocessor then determines if a compact wireless data packet should be broadcast to the site manager or wireless controller / receiver. This data packet includes the gas value, alarm and fault status bits and battery voltage.

At the conclusion of each "Wakeup Timer" interval, the GASMAX/TX also transmits a larger data packet containing additional information that includes zero and span values, user-programmed tag and engineering unit values and communications timeout settings. Third-generation controllers such as the C2/TX Wireless Site Manager process and display this information, eliminating the need to program both the gas monitor and site manager or controller.

**NOTE: GDS CORP WIRELESS GAS DETECTORS CAN ONLY COMMUNICATE WITH PROPERLY EQUIPPED GDS CORP CONTROLLERS OR WIRELESS SYSTEM / SITE MANAGERS.**

If the GASMAX/TX determines that a data packet should be transmitted, the following events take place: Power is applied to the radio, the radio is placed in receive mode and listens for the synchronization beacon transmitted by the site manager or controller / receiver. If the beacon is found, the radio synchronizes to the beacon hopping pattern, transmits the data packet and returns to sleep mode. This sequence takes between 250 milliseconds and 1 second to complete. If the radio fails to synchronize with the beacon, it waits 2 seconds and tries again, then waits 2 seconds and tries once more. If the third attempt fails an "Out of Range" icon is displayed and the GASMAX/TX goes to sleep until the next six second interval occurs. The "Out of Range" event will be logged in the Event Log.

FHSS radios for both 900 MHz and 2.4 GHz are available. For North America, 900 MHz is recommended due to increased power output available (up to 1 watt), greater range and ability of lower frequency signals to travel around interfering objects. Systems utilizing 2.4 GHz radios transmit at lower power levels and have corresponding less range. In addition, higher frequency 2.4 GHz signals tend to require a more direct 'line of sight' between the gas detector and controller / receiver antenna. On the other hand, 2.4 GHz systems are generally license-free world-wide and are generally less prone to interference from other radio frequency sources.

**NOTE: CHOICE OF FREQUENCY IS MADE AT TIME OF ORDER. SYSTEMS DESIGNED FOR 900 MHZ CANNOT BE FIELD UPGRADED TO 2.4 GHZ AND VICE-VERSA.**

Once the choice of frequency band is made, every device in the network must have a matching **Network Identifier** ("A" - "Z") that determines the radio's frequency hopping pattern and system identifier. In addition, each GASMAX/TX must also have a unique **device ID** (1 - 240) that allows the controller to identify the specific gas detector. Finally, there must be one device that transmits the synchronizing Beacon signal that all radios use to synchronize their transmissions.

While the GASMAX/TX is optimized for use with third-generation controllers such as the C2/TX Wireless Site Manager, the GASMAX/TX can also be integrated into existing wireless networks that utilize a C1 *Protector* 16-channel controller, C64 *Protector* 64-channel controller or C2 *Quad Protector* 4-channel controller. In "legacy mode", the required 'Hop Channel', 'System ID' and 'RTU Address' values can be programmed to match an existing network, and many of the benefits, including magnetic Power On / Power Off, advanced 10-97xx sensor technology and additional transmission modes will still offer benefit to the user. However, when in legacy mode, packet data that includes sensor range, tag name and engineering units is not transmitted to the controller and must be manually entered in both the receiver/controller and gas detector.

## 5 WIRELESS SYSTEM BASICS

### SYSTEM ARCHITECTURE

GDS Corp wireless uses discrete Frequency-Hopping Spread-Spectrum radios to communicate gas and alarm level information wirelessly between gas detectors and controllers. FHSS radios transmit individual data packets using different discrete frequencies in a pseudorandom sequence (“Hop Pattern”) known to both transmitter and receiver. Unlike Direct-Sequence Spread Spectrum (DSSS) used for short distance 802.11 b/g “WiFi” and certain mesh networks, FHSS technology provides an ideal balance between power consumption, transmission distance and resistance to interference.

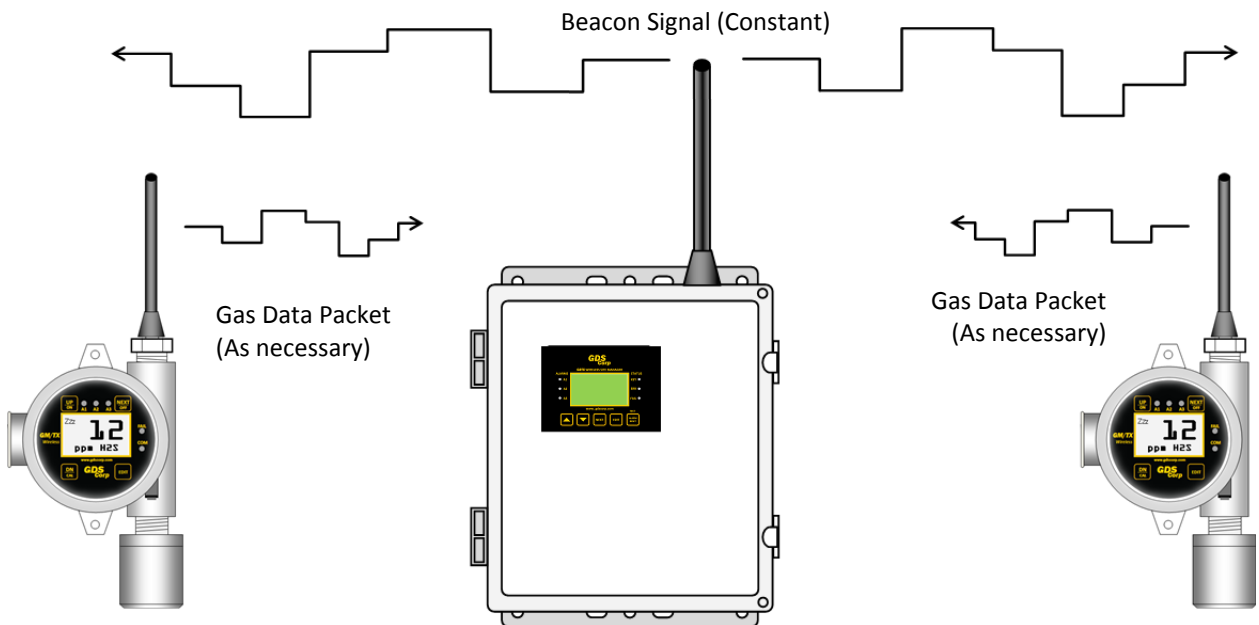
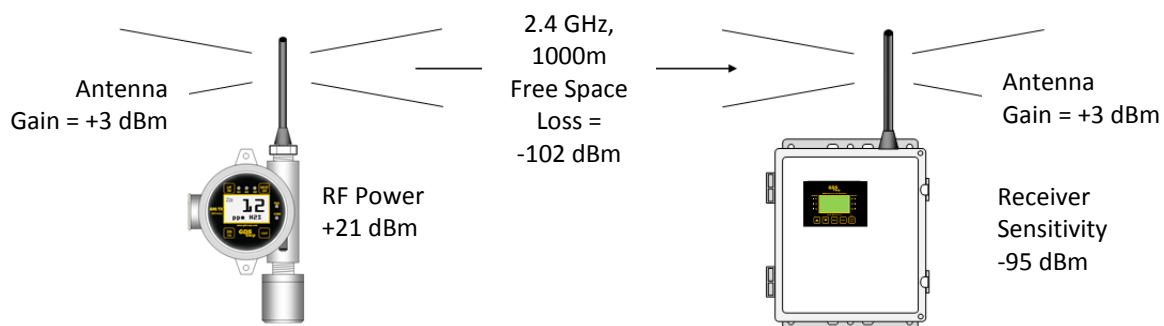

**Figure 5-1: GDS Corp Wireless System Architecture**

In each GDS Corp system, one device is configured as the “beacon server”. This device transmits a modulated carrier signal that all other radios use to synchronize their frequency-hopping pattern. Knowledge of the selected hopping pattern programmed into the radio and synchronization data from the beacon enables each radio to know when to transmit, and on what frequency. Multiple networks can exist in the same frequency band so long as their choice of pseudorandom hopping pattern is unique. GASMAX/TX monitors support 26 unique network identifiers.

## TRANSMISSION DISTANCE

In order for reliable wireless communication to occur, transmitter power output, antenna 'gain' and receiver sensitivity must exceed the 'free space loss' attenuation experienced by radio signals as they travel between transmitter and receiver. This gain or loss is measured in decibel-milliwatts (dBm) and is a function of both distance and frequency. Typical free space loss at 900 MHz is -71 dBm at 300 ft / 100 meters and -91 dBm at 3000 ft / 300 meters, and for 2.4 GHz the free space loss is -80 dBm at 300 ft / 100 meters and -100 dBm at 3000 ft / 1000 meters.

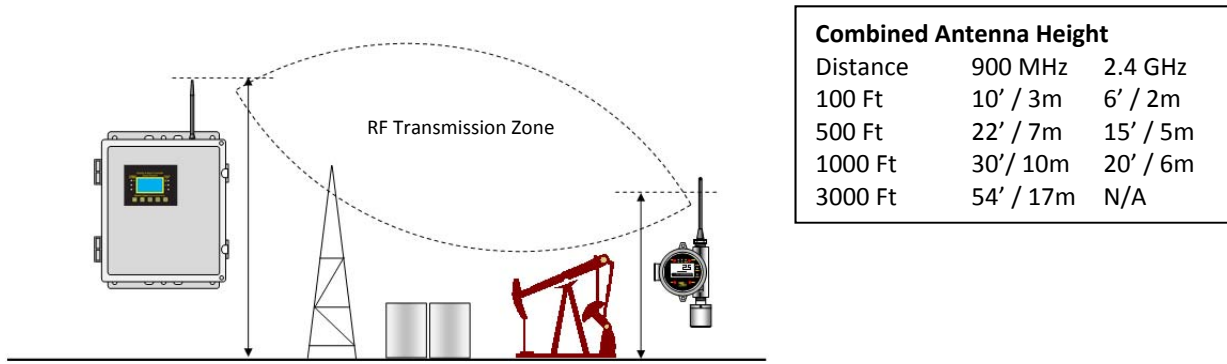

**Figure 5-2: RF Transmission Margin**

In a typical 2.4 GHz system shown above, for example, the transmitter power output is +21 dBm, each antenna provides an additional gain of +3 dBm and the receiver sensitivity is -95 dBm. Therefore, the total system gain is  $21+3+3-(-95) = 122$  dBm. Since a reliable system requires a margin of +20 dBm, this system will work if the free space loss between the transmitter and receiver is less than 102 dBm, suggesting a distance of approximately 1000 meters. However, this calculation does not take into account additional losses due to intervening structures or foliage.

To minimize free-space loss, the combined height of the transmitter antenna and receiver antenna should exceed the diameter of the "RF Transmission Zone" (see Fig. 5-3) and at least 60% of the area inside the zone should be free of obstacles. Although both 900 MHz and 2.4 GHz signals can travel around or through most towers or buildings, structures such as large metal tanks or solid metal buildings may attenuate the signal to the point where reception is marginal.

Raising the antenna at either end of the path will improve signal strength and reduce transmission errors. GDS Corp recommends placing the GASMAX/TX at least 5 feet above the surrounding terrain, and even more if possible. However, note that the standard antenna transmits its maximum signal strength in a relatively flat 'donut-shaped' pattern which may affect the performance of GASMAX/TX monitors located in close proximity to an elevated C2/TX Site Manager or receiver/controller.



**Figure 5-3: RF Transmission Zone**

GDS Corp always recommends that a wireless survey be completed at the site to ensure the integrity of the wireless communications link. Special care should be taken to account for moveable obstacles such as cranes, railroad cars, trucks, containers, and any other large ‘structures’ that could end up being placed – temporarily – in a location that blocks the wireless signal.

### **MONOPOLE AND COLLINEAR OMNI-DIRECTIONAL ANTENNAS**

Monopole “rubber duck” antennas are the most commonly used antennas for portable and semi-portable equipment where extreme range or directional reception is required. When mounted vertically, they provide good ‘omnidirectional’ reception and transmission from all horizontal directions, and are generally rugged and when sealed properly against moisture can provide years of quality service.

Collinear antennas are more sophisticated and combine several vertical antennas that operate in parallel to increase signal gain by focusing the reception pattern in a more horizontal plane.

Rubber duck and collinear antennas provide best performance when installed with at least 1 to 2 “wavelengths” away from walls or steelwork. Since wavelength proportional to frequency, 900 MHz signals have a wavelength to approximately 12 inches and 2.4 GHz signals have a wavelength of about 3 inches. **Therefore, 900 MHz antennas should be installed with at least 2 feet of clearance and 2.4GHz antennas at least 6 inches of clearance from walls or structures.** Antennas may be mounted with less clearance but output will be reduced; this may not matter if the distances involved are short. It is important the antenna mounting bracket to well connected to “earth” or “ground” for good lightning surge protection.

Rubber duck or collinear antennas emit RF energy in ‘vertical polarization’, where the electric fields oscillate in the vertical plane and the magnetic fields oscillate in the horizontal plane. Transmitting and receiving antennas should always be oriented such that the polarization is the same.

## YAGI DIRECTIONAL ANTENNAS

Yagi antennas are directional along the central beam of the antenna. The folded element is towards the back and the antenna should be “pointed” in the direction of the transmission. Yagi antennas should also be mounted with at least 1 to 2 wavelengths of clearance from other objects. The polarity of the antenna is the same as the direction of the orthogonal elements. For example, if the elements are vertical the Yagi transmits with vertical polarity.

In networks spread over wide areas, it is common for a central receiver / controller to have an omni-directional antenna (such as a collinear) and the remote GASMAX/TX monitors to have Yagi directional antennas. In this case, as the omni-directional antenna will be mounted with vertical polarity, then the Yagi’s must also have vertical polarity (see Fig. 5-3). Care needs to be taken to ensure the Yagi is aligned correctly to achieve optimum performance.

Two Yagi antennas can be used for a point-to-point link. In this case they can be mounted with the elements horizontally to give horizontal polarity. There is a large degree of RF isolation between horizontal and vertical polarity (~30dB) so this installation method is recommended if there is a large amount of interference from another system close by transmitting in vertical polarity.

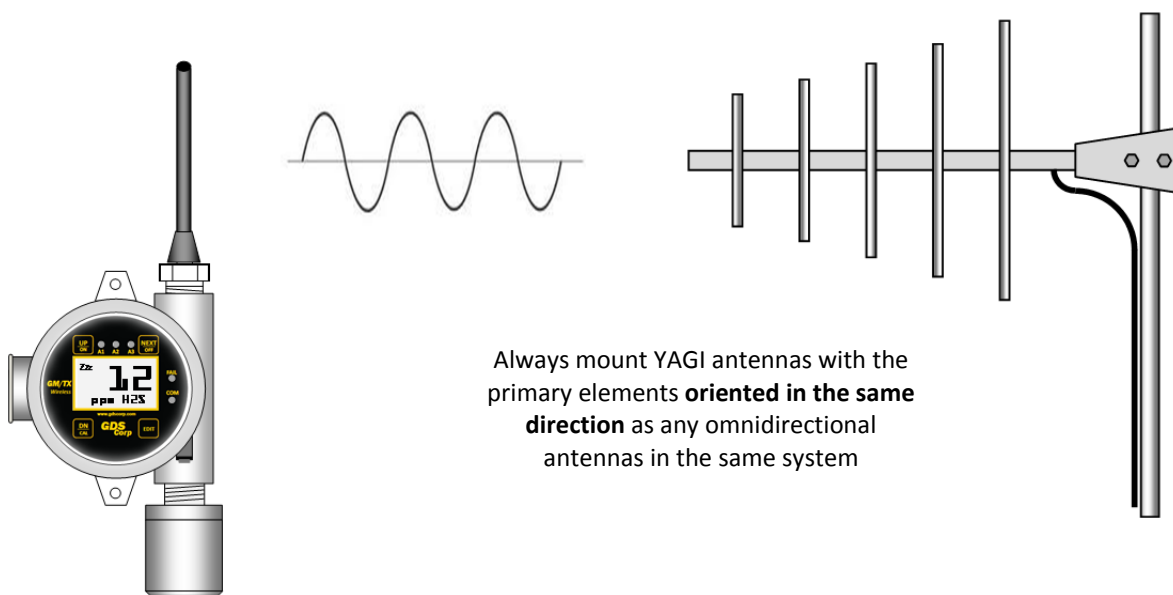

Figure 5-4: Vertically Polarized Omni-Directional and YAGI Antennas

## COAXIAL CABLES

When installing a coaxial cable between the GASMAX/TX and a remote antenna, constructing a loop of cable below the antenna is always recommended. The loop allows water to drip off the bottom of the U

instead of into the connection, reduces installation strain and provides spare cable length in case later the original connectors need to be replaced.

Avoid installing coax cables together in long parallel paths. Leakage from one cable to another has a similar effect as mounting an antenna near another antenna.

## **SURGE PROTECTION & GROUNDING**

Voltage surges primarily enter the GASMAX/TX via the antenna connection as a result of electrical discharge in the atmosphere. Electrical energy follows the most direct path to earth and the best protection is achieved by “draining” the surge energy to earth via an effective earth ground. Wireless devices should have a solid connection to earth via a ground stake or ground grid if the soil has poor conductivity. Solid connection means a large capacity conductor (not a small wire) with no coils or sharp bends. All other devices connected to the GASMAX/TX, such as remote sensors, should be grounded to the same ground point if possible. There can be significant resistance between different ground points leading to very large voltage differences during lightning activity. As many wireless units are damaged by earth potential surges due to incorrect grounding as direct surge voltage.

It is very difficult to protect against direct lightning strikes but the probability of a direct strike at any one location is very small. Unfortunately, power line surges and electromagnetic energy in the air can induce high voltage surges from lightning activity several miles away.

## 6 HARDWARE OVERVIEW

The GASMAX/TX is a self-contained, battery-operated single or dual channel gas detector with local or remote sensors. The unit consists of an explosion proof enclosure, sensor head (if utilizing a local sensor), antenna tuned for either 900 MHz or 2.4 GHz frequency bands, a display module with microprocessor and radio and I/O battery board that doubles as mounting hardware for the display. The display attaches to the I/O battery board via a short multi-pin cable and two captive thumbscrews.

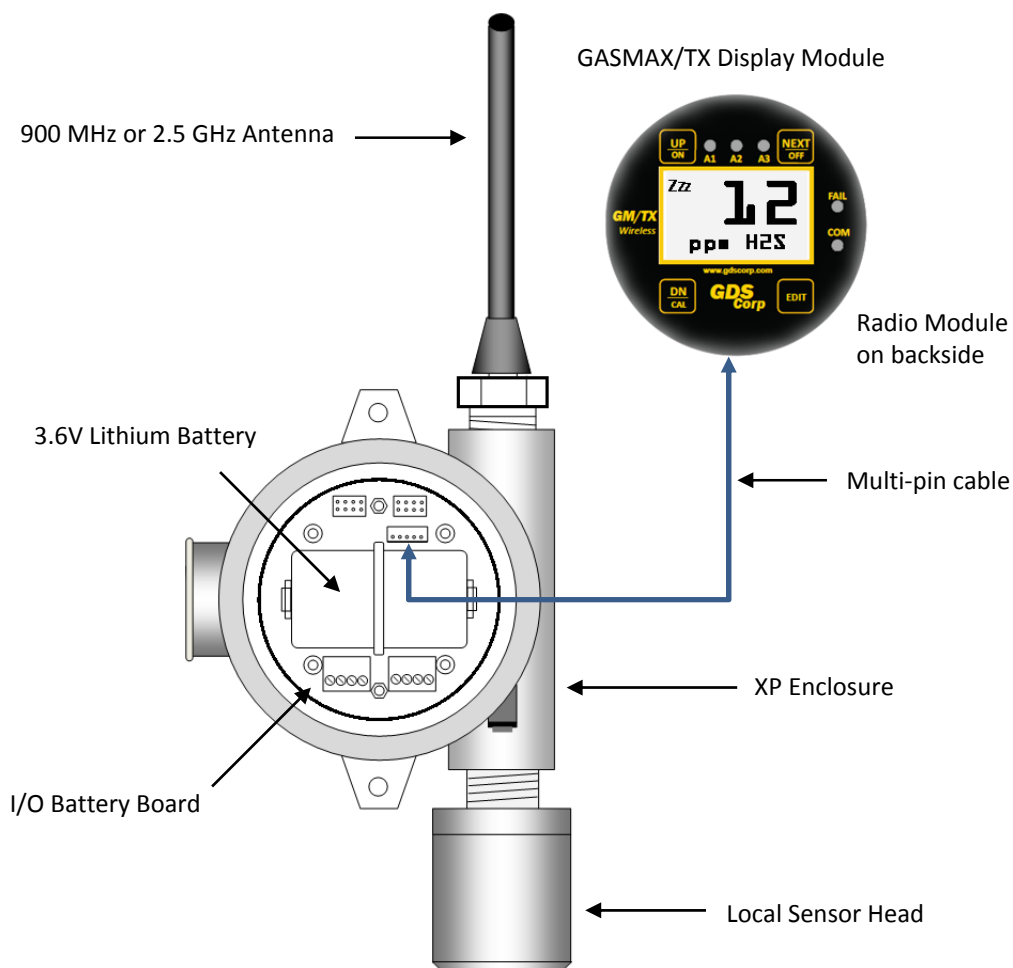

**Figure 6-1: GASMAX/TX with Single Local Sensor**

The GASMAX/TX wireless gas monitor is capable of monitoring two separate sensors. In certain cases, it is appropriate to co-locate both sensors in a 'local sensor' configuration. When doing so, the GASMAX/TX is configured with a Y-adaptor that supports two independent electrochemical or infrared sensors (See Fig. 5-2).

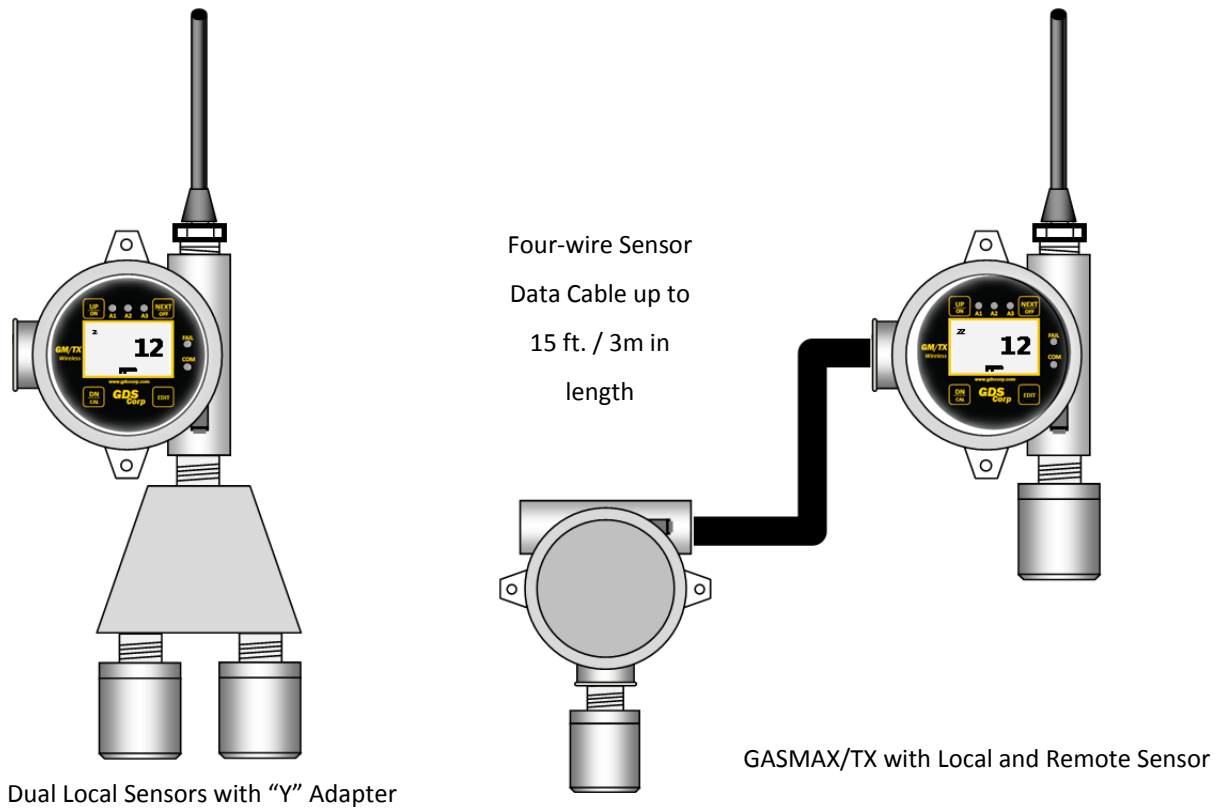

**Figure 6-2: GASMAX/TX with Dual Sensors**

The GASMAX/TX also supports remote sensors located up to 15 feet from the GASMAX/TX display. Figure 6-3 shows the Sensor Separation Kit required for each remote sensor.

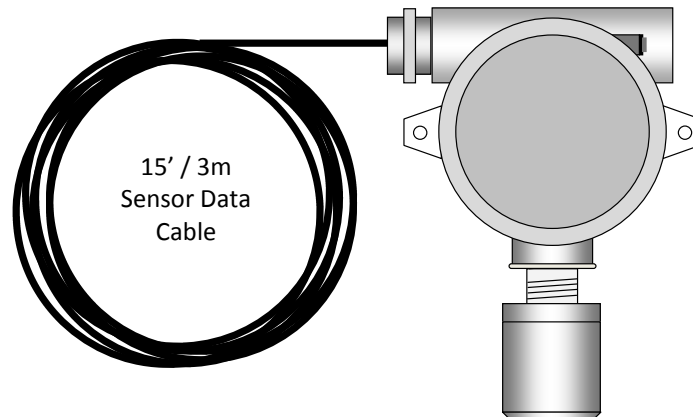

**Figure 6-3: P/N 10-0411 Remote Sensor Separation Kit**

## 7 INSTALLATION

### LOCATING THE GASMAX/TX

Factors such as air movement, gas density in relation to air, emission sources and environmental variables affect correct sensor location. Air movement by fans, prevailing winds and convection should be carefully evaluated to determine if a leak is more likely to raise gas levels in certain areas within the facility. Vapor density of a gas determines if it will rise or fall in air when there are no significant currents. Lighter than air gases should have the monitors mounted 12 – 18 inches (30 – 45 cm) above the potential gas leak and heavier than air gases should be this distance below. Even though the GASMAX/TX is designed for rugged service, sensors should be protected from environmental damage from water, snow, shock, vibration and dust and dirt.

### MOUNTING THE GASMAX/TX

The GASMAX/TX standard enclosure is a cast aluminum explosion-proof (NEMA 7) enclosure and should always be mounted with the sensor head opening facing down. If necessary, a Splash Guard (p/n 10-0205) should be attached if there is any chance that water or liquid spray could enter the sensor opening from below. Be sure to leave sufficient room below the sensor head to allow easy access for attachment of a Calibration Cup and / or removal of the sensor head cover for sensor replacement.

Whenever possible, the GASMAX/TX should be mounted in a location that provides clear line-of-sight between the gas monitor and receiving antenna. Both 900 MHz and 2.4 GHz signals will travel through masonry or wooden structures with minimal loss; however, large metal buildings, tanks and other solid structures will block the signal or attenuate the transmission to the point where reliable wireless communications may not be possible. For 900 MHz radios, power levels can be adjusted from 10 mW up to 1.0 watt (higher power will reduce battery life). In many cases, GDS-95 Wireless Repeaters can be used to route wireless signals around obstacles.

Height above ground also affects wireless transmissions, and raising the antenna at either end of the path will improve signal strength and reduce transmission errors. GDS Corp recommends placing the central receiver antenna at least 10 feet about the surrounding terrain, and even more if possible. However, note that standard vertical dipole antennas transmit their maximum signal strength in a relatively flat 'donut-shaped' pattern which may affect the performance of GASMAX/TX monitors located close to an elevated central antenna.

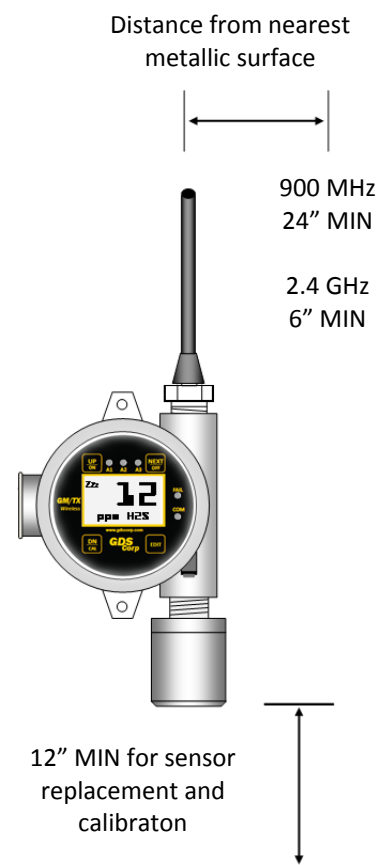

## POWER AND SIGNAL WIRING

The GASMAX/TX is completely self-contained. Power is provided by the internal 3.6V battery, and output data is sent entirely via wireless transmission from the local or remote antenna.

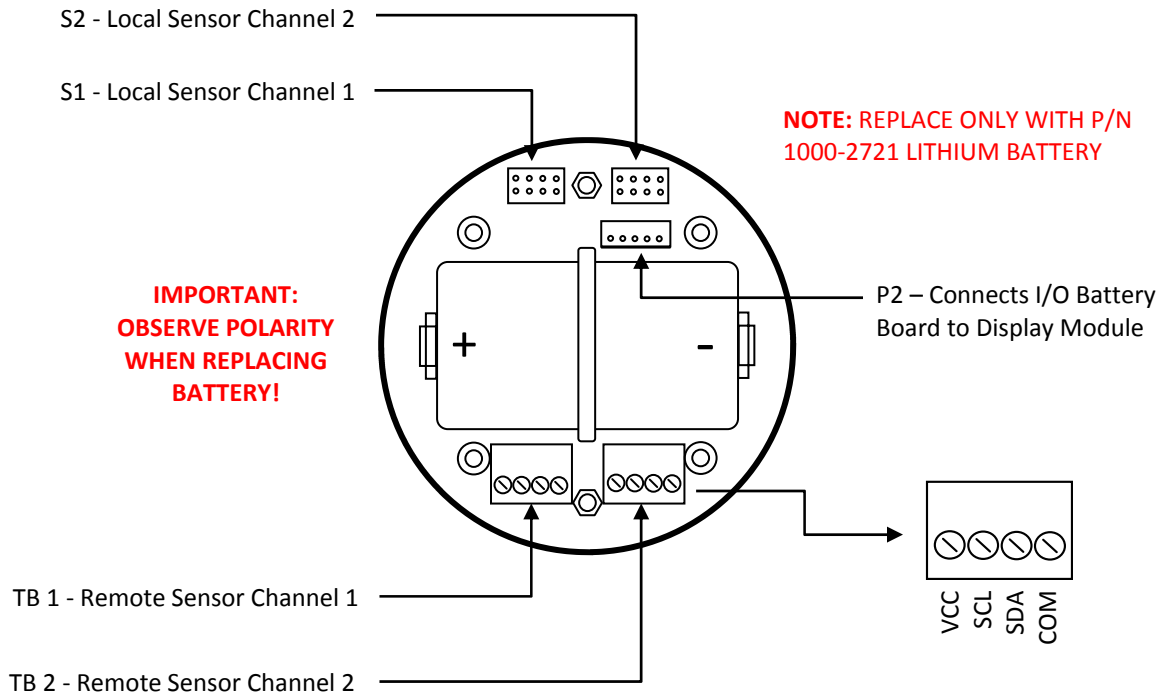

**Figure 7-1: GASMAX/TX I/O Battery Board**

The multi-pin interface cable from local sensor heads connects to “S1” for channel 1 and to “S2” for channel 2. Four-wire sensor extension cables for remote sensors connect to “TB-1” for channel 1 and to “TB-2” for channel 2. When replacing the battery be careful to double-check the polarity before installing. Reversing the polarity will damage the internal electronics.

## CONNECTING A REMOTE ANTENNA

Additional information on remote antennas will be available in a future version of the GASMAX/TX manual.

## CONNECTING A GASMAX/TX REMOTE SENSOR

The GASMAX/TX remote sensor consists of a cast aluminum explosion-proof junction box, stainless steel sensor head and 15' / 3m length data cable. The junction box contains a PCB with connection point for the sensor head cable and wiring terminals for the four-wire digital data cable connection to the GASMAX/TX display enclosure. Fittings are  $\frac{3}{4}$ " NPT. The sensor head should ALWAYS be mounted vertically as shown, and GDS Corp recommends side entry for all conduit runs.

**NOTE: THE SENSOR SEPARATION KIT DATA CABLE CAN BE CUT TO ANY LENGTH FROM THE 15 FT / 3M CABLE PROVIDED. THE DATA CABLE SHOULD NOT BE LENGTHENED.**

GASMAX/TX monitors with remote-mount sensors are shipped as separate pieces and must be assembled by the customer. The data cable connects to the I/O battery board in the GASMAX/TX, using "TB1" for channel 1 and "TB2" for channel 2. Connect the VCC, SCL (serial clock), SDA (serial data) and Common as shown.

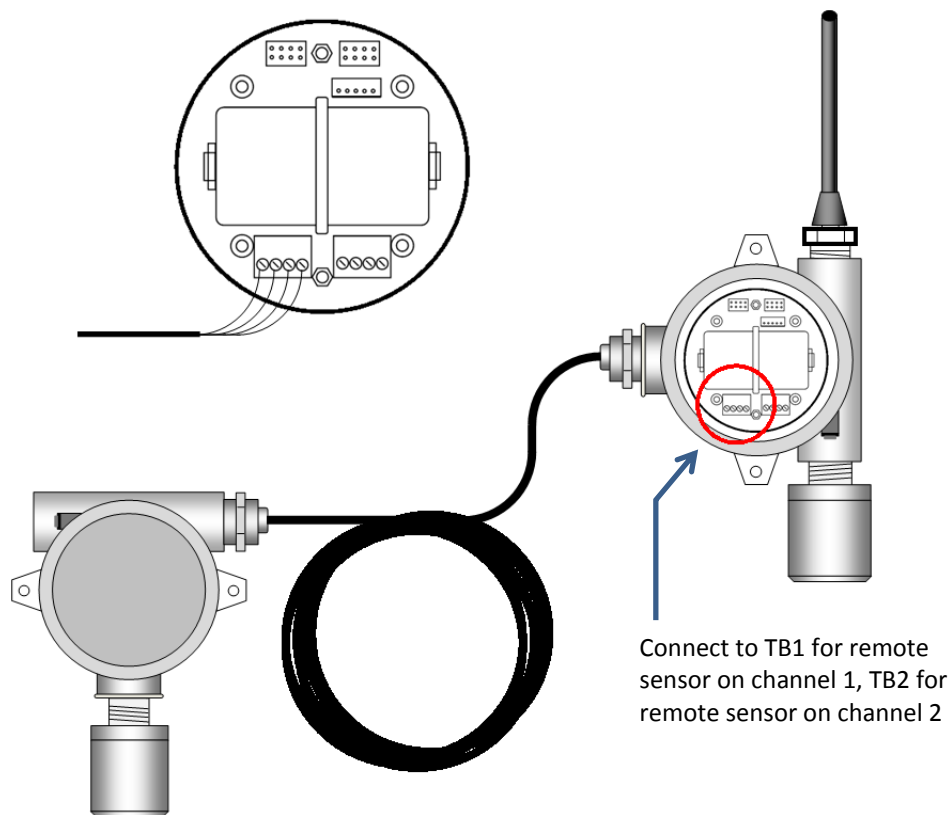

**Figure 7-2: Connecting a GASMAX/TX Remote Sensor**

## **SEALING ANTENNA AND CABLE FITTINGS**

If a coax cable connects to the antenna via connectors, it is very important to weatherproof the connection using #1000-2314 or equivalent sealing tape. Moisture ingress into a coax cable connection is the most common cause of problems with antenna installations. A three layer sealing process is recommended – an initial layer of electrical PVC tape, followed by a second layer of self-vulcanizing weatherproofing tape (#1000-2314), with a final layer of electrical PVC tape.

## **USE IN HAZARDOUS AREAS**

The GASMAX/TX enclosure and sensor head with integral flame arrestor are certified for use in Class 1 Division 1 hazardous areas. When combined with the optional XX Class I Division 1 antenna coupler, the entire device is suitable for use in Class 1 Division 1 areas. The standard 10-0295 antenna coupler is designed to meet Class I Division 2 hazardous area standards but is not 3<sup>rd</sup> party certified. GASMAX/TX detectors with sensor heads for reactive gases (without flame arrestors) should not be installed in hazardous areas.

## 8 INITIAL SETUP

### POWER-ON AND USER INTERFACE

To turn on the GASMAX/TX hold the magnetic wand over the UP/ON key for several seconds. The welcome screen will appear, followed by the sensor information screen. The GASMAX/TX will then enter a predefined warm-up delay period to allow the sensor to stabilize. If the unit does not power up properly, check for a loose battery connection or dead battery.

**NOTE: GDS CORP RECOMMENDS APPLYING POWER TO THE GASMAX/TX AFTER THE SITE MANAGER SYNCHRONIZING BEACON SIGNAL IS ACTIVE. BATTERY LIFE IS REDUCED IF THE GASMAX/TX IS ON FOR LONG PERIODS WHILE UNABLE TO COMMUNICATE TO THE MASTER DEVICE.**



Figure 8-1: GASMAX/TX Display

The GASMAX/TX display is shown in Figure 8-1. There are four magnetic switches on the face of the GASMAX/TX, arranged in a quadrant around the LCD display labeled “NEXT”, “EDIT”, “DOWN/CAL” and “UP/ON”. To activate, or “press” a magnetic switch, swipe the magnet near the switch. To access the Main Menu, press the “EDIT” key while in display mode. Pressing the NEXT key causes the GASMAX/TX display to switch display screens between DATA and TREND displays. Activating DOWN/CAL, followed by EDIT, while in display mode initiates Calibration Mode.

The EDIT key activates the USER MENU display mode. When in user menu display mode, use UP and DOWN to select an item, EDIT to change an item, and NEXT to exit the menu or function and return the GASMAX/TX to display mode. For the balance of this manual, the term “press” will be used to describe activation of any key via the magnetic wand. See Chapter 11 for a detailed description of the User Menu.

All that is necessary to integrate a GASMAX/TX into a GDS Corp wireless network is to select the **Network Identifier** and **Device ID**. Each device in any given GDS Corp wireless network should have the *same* Network Identifier, and each GASMAX/TX should have a *different* Device ID.

To access the necessary menu, press EDIT and select the *Device Setup – RF Link Setup* Menu. See Figure 8-2 for a step-by-step procedure to integrate multiple GASMAX/TX devices with a C2/TX Wireless Site Manager.

To turn the GASMAX/TX OFF, access the *Device Setup – Turn Power Off* menu, or hold the magnet over the NEXT key until the display shows “EDIT to Accept, and then press the EDIT key.

## SETTING UP THE GASMAX/TX AND C2/TX WIRELESS SITE MANAGER

To successfully setup a wireless network, perform the following steps in order:

	GASMAX/TX Gas Monitor	C2/TX Wireless Site Manager
1		Apply AC or DC power to the C2/TX Wireless System Manager
2		Select the desired network identifier ("A" through "Z")
3		If the C2/TX is the primary or only controller in the network, select RF Mode = "Server"
4		If using 900 MHz radios, set the desired transmit power output
5		Enable the desired number of wireless channels in the C2/TX WSM
6	Turn on the GASMAX/TX by holding a magnetic wand over UP/ON key for several seconds	
7	Configure the network identifier ("A" thru "Z") to match that chosen for the C2/TX WSM or system controller. <i>Find in "Device Setup – RF Link"</i>	
8	Configure the RTU # (device ID) for a unique value <i>Find in "Device Setup – RF Link"</i>	
9	Program channel tag name (if desired) <i>Find in "Channel Setup"</i>	
10		Select C2/TX channel and set Remote Address to match device ID on GASMAX/TX
11	Hold magnetic wand over UP key to force initial transmission	Confirm reception of wireless transmission and valid gas detector reading
xx	Repeat for Each GASMAX/TX	Repeat for each GASMAX/TX
12		Program relays and alarm conditions for desired outputs
	Perform end-to-end test using calibration or test gas	

**Figure 8-2; Step-by-Step Setup Checklist**

After power-up, allow the GASMAX/TX to stabilize for one to eight hours prior to any initial calibration (see GDS Corp Electrochemical Sensor manual for more details on specific electrochemical sensors). This will allow the sensor to reach stable equilibrium with respect to environmental conditions such as ambient temperature, humidity, and barometric pressure as well as applied “reference” and “counter” voltages generated by the GASMAX/TX electronics. At this point, the GASMAX/TX can be calibrated and made operational.

### **INITIAL SETUP – LEGACY MODE**

Additional information will be available in a future version of the GASMAX/TX manual.

## 9 CALIBRATION

### CALIBRATION OVERVIEW

Calibration is critically important to ensure correct operation of the GASMAX/TX. The built-in CAL MODE function is designed to make calibration quick, easy and error free; a successful ZERO and SPAN calibration requires only four keystrokes.

When entering CAL MODE, the GASMAX/TX automatically transmits a data packet containing a value of 300 counts (-15.6% of scale) to enable properly programmed GDS Corp controller / receivers to indicate IN CAL for the current channel. Once CAL SPAN is complete, the GASMAX/TX transmits a data packet containing a value of 800 counts (0% of scale). However, if an oxygen sensor is detected, then the GASMAX/TX will transmit a data packet with a value of 3475 counts (83.6% of scale) to simulate the typical 20.9% value found in atmospheric oxygen levels.

CAL MODE automatically exits if no keystrokes are detected after 5 minutes.

Follow these GASMAX/TX calibration guidelines:

- Calibration accuracy is only as good as the calibration gas accuracy. GDS Corp calibration gases are traceable to NIST (National Institute of Standards and Technology).
- **Never use calibration gas that has passed its expiration date.**
- Check the SPAN GAS VALUE setting and make sure it matches the calibration gas. (See Fig. 6-2)
- Always use a GDS Corp calibration cup that completely surrounds the sensor head.
- Be sure to use ZERO AIR, a mixture of 21% oxygen and 79% nitrogen, as a zero reference unless you are certain that no target gas exists in the area. Ambient gas may result in an 'elevated zero' condition that will cause a FAULT to occur once the ambient gas is no longer present.
- **Always calibrate a new sensor before depending on the device for personnel or equipment safety**
- Calibrate on a regular schedule. GDS Corp recommends a full calibration every 3 months, with periodic 'bump tests' on a more frequent basis to ensure that the sensor has not been affected by temperature extremes or the presence of incompatible gases.

## CALIBRATION PROCEDURE

Before beginning calibration, make sure you have the following items: A cylinder of calibration gas, fixed flow regulator and an appropriate calibration cup connected to the regulator via a length of flexible tubing. If necessary, a cylinder of 'zero air' may be necessary if the absence of target gas cannot be confirmed. GDS Corp recommends a flow rate of 0.5 liters / minute for standard gases and a flow rate of 1.0 liters / minute for highly reactive gases such as chlorine or chlorine dioxide.

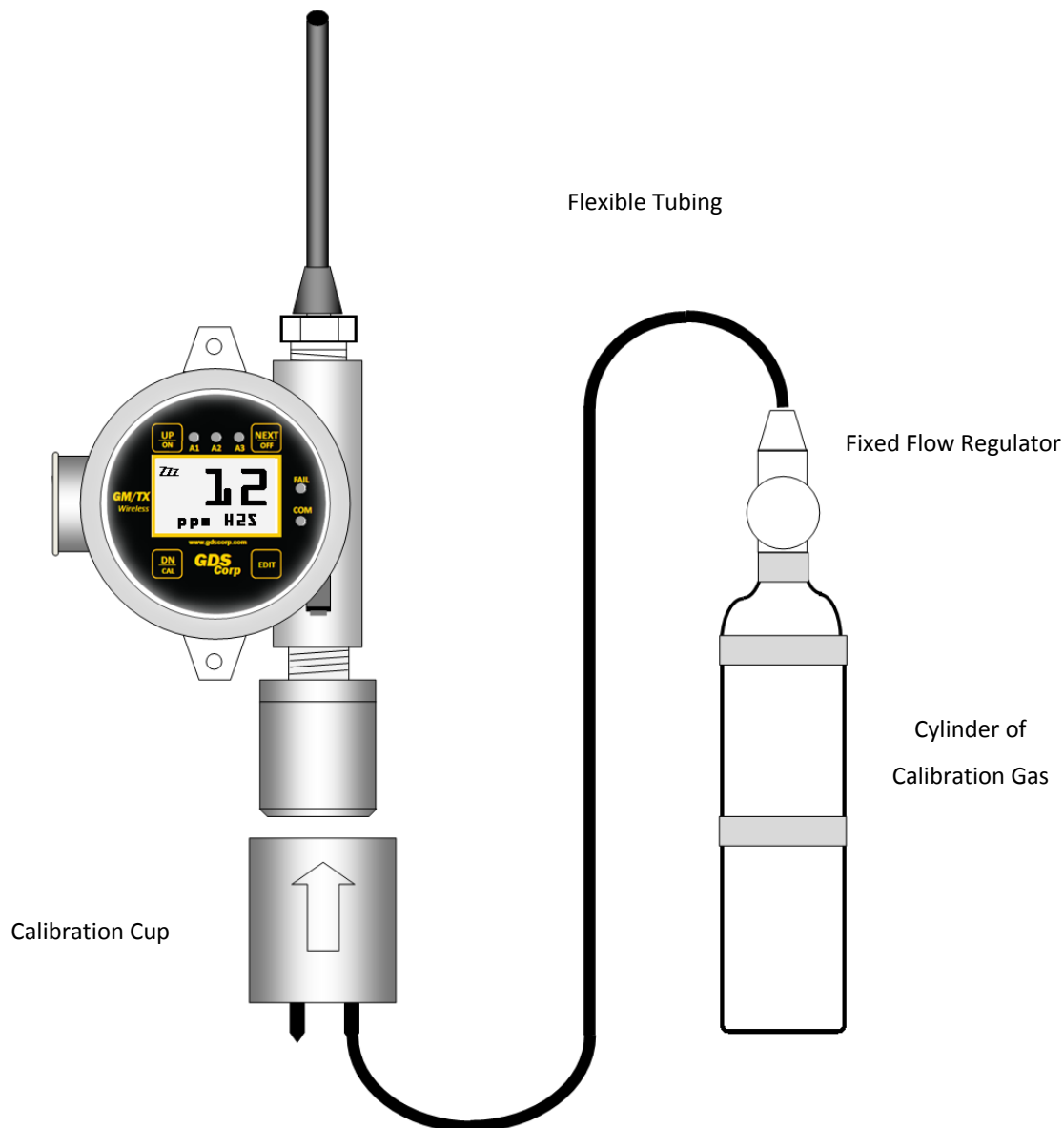

**Figure 9-1: Calibration Setup**

To calibrate a GASMAX/TX detector:

1. To enter CAL MODE, press the DOWN / CAL key and within 5 seconds press the EDIT key.
2. The screen will display an APPLY ZERO message. Using the setup shown in Fig. 5-1, apply clean ZERO air unless it can be guaranteed that no target gas is present. After the reading stabilizes, press the EDIT key to complete the ZERO calibration.
3. If the ZERO CAL SUCCESSFUL message is displayed, an APPLY SPAN message will appear. Apply the correct SPAN gas. After the reading is stable, (approximately 1 minute) press the EDIT key to complete the SPAN GAS calibration. If the SPAN calibration is successful, the display flashes REMOVE CAL GAS and starts the CAL PURGE delay.
4. Immediately shut off the regulator and remove the calibration cup. At the end of the CAL PURGE delay, the GASMAX EC output is re-enabled and the unit is fully operational.

The flow chart shown in Figure 5-2 illustrates the above procedure. UP, CAL, NEXT & EDIT labels indicate keystrokes using the magnetic wand. ZERO or SPAN calibration will fail if the readings exceed built-in limits for maximum allowable zero or minimum allowable span.

**NOTE: A CAL MODE INFO SCREEN IS AVAILABLE TO VIEW CERTAIN CAL MODE PARAMETERS DURING CALIBRATION. HOLD THE UP KEY FOR 5 SECONDS DURING CAL MODE TO DISPLAY THIS SCREEN.**

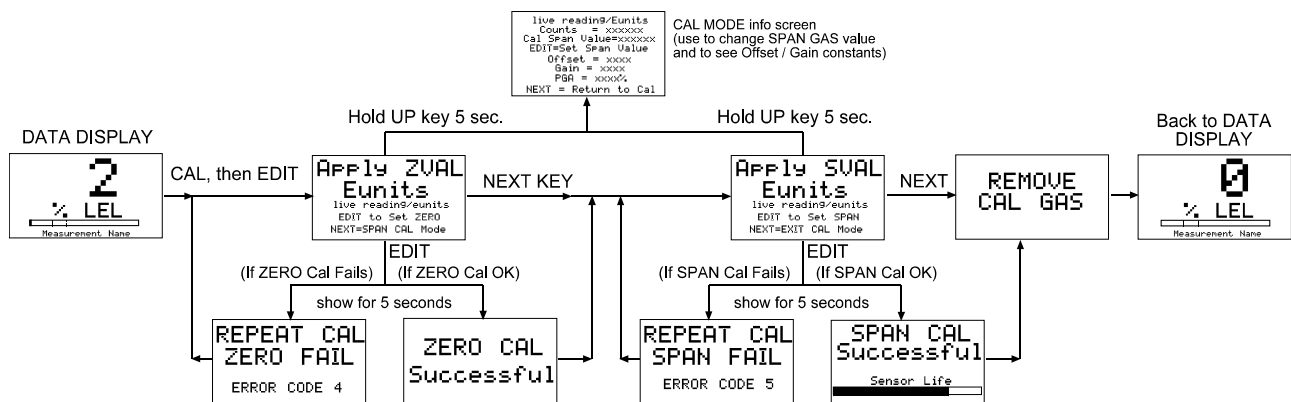
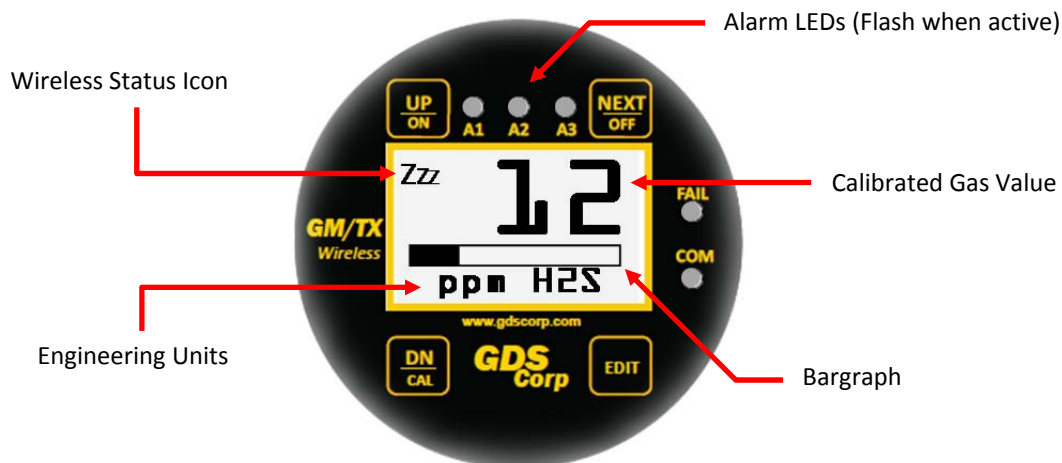

Figure 9-2: CALIBRATION FLOWCHART

## 10 OPERATION AND MAINTENANCE





### DATA DISPLAY SCREEN

The DATA display screen shows real-time channel value information in calibrated engineering units. A horizontal bar graph tracks the current value and shows the Alarm 1 and Alarm 2 values in graphical form. In single-channel display mode, user-programmable Engineering Units (“Eunits”) and Measurement Name text strings are shown below the real-time reading.



**Figure 10-1: GASMAX/TX Data Display Screen**

A “Wireless Status Icon” appears in the upper left corner of the data display screen to indicate the status of the wireless interface. The information shown includes:

- Zzz** Indicates that the GASMAX/TX microprocessor is in low-power sleep mode.
- SNIFF** Indicates that the GASMAX/TX microprocessor is awake and reading the sensor data.
- RNG** Indicates that the GASMAX/TX is trying to synchronize with the beacon.
-  Indicates that the beacon was successfully detected and that a data transmission is in progress.
-  Indicates that the beacon signal was not received during the most recent attempt to transmit data. The GASMAX/TX will not attempt to transmit until a beacon signal is present.
-  Indicates a “Range Warning”. This icon is presented if the server was previously out of range for any reason and can be reset using the *Device Setup – Reset Range* Icon menu.
-  **LoBat** Low battery indication. Displayed during each “sniff cycle” if the battery is near the end of its useful life.

## TREND AND DUAL DATA DISPLAY SCREENS

Pressing the “NEXT” key allows the user to cycle through the available data and trend screens. In single channel mode, there are only two screens – Data Display and Trend Display. If both channels are active, there are two Data Display screens, two Trend Display screens and one Dual Data Display screen that shows both channels values and alarm status.

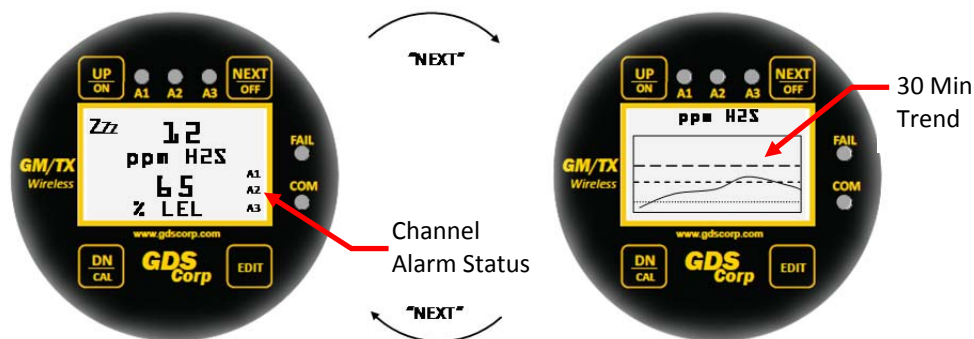

Figure 10-2: Dual Data and Trend Display Screens

## NORMAL OPERATION

Every six seconds, the GASMAX/TX reads the sensor’s digital output, converts the reading to calibrated engineering units and displays the value on the LCD display. Based on the gas concentration level and alarm levels programmed by the user, the microprocessor determines if a compact wireless data packet should be broadcast to the site manager or wireless controller / receiver. This data packet includes the gas value, alarm and fault status bits and battery voltage. The GASMAX/TX will initiate a data packet transmission under the following specific conditions:

- Every time the **Wakeup Timer** expires, irrespective of the gas level present. This allows controller / receivers to confirm the presence of the gas monitor or issue a COMM ERROR is no transmission is received in a fixed interval (default is 18 minutes, but can be adjusted by the user).
- IF the new reading exceeds the **Alarm 1, Alarm 2 or Alarm 3** programmed value. A sensor FAULT reading does not initiate a transmission, but will be broadcast on the Wake-Up timer interval.
- If the reading rises or falls **by more than 2% of full scale** as compared to the last reading.
- Upon **entry into CAL mode**, a packet containing a gas value of 300 counts (-15.6% of scale) is transmitted to indicate IN CAL for the current channel.
- Upon **entry into CAL PURGE mode**, a value of 800 counts (0% of scale) is transmitted for all sensors except oxygen sensors, where a value of 3475 counts (83.6% of scale) is transmitted.
- Holding the magnetic wand **over the UP key** until the Data Transmission icon appears.

- At the **end of the initial Warm-Up** interval
- Any time **menu items are edited** and again upon returning the display to readings mode.

## **OPTIMIZING BATTERY LIFE**

The 3.6v lithium battery in the GASMAX/TX should last between six and 12 months under normal conditions if gas is only occasionally present. To optimize battery life, consider the following options:

- **Set the Wakeup Timer to its maximum value of 5 minutes (300 seconds)** - Shortening the Wakeup Timer will increase the number of transmissions and reduce battery life. However this will also reduce the amount of time that a gas detector can be inactive before the Wireless Site Manager or receiver/controller will signal a "COMM ERROR".
- **Reduce the power output for 900MHz radios** – Transmit power at 900 MHz can be adjusted from 1 watt (max) down to 10 milliwatts (min). Since most of the power consumed by the GASMAX/TX is used by the radio to transmit, reducing the power output will increase battery life. However, this will reduce the strength of the transmitted signal and may increase communications errors.
- **Setting the TX Multiples value** – The TX Multiples menu setting enables every broadcast to be repeated up to five times with a 200 mSec delay between each transmission. Increasing the TX Multiples value will increase battery usage, but may reduce communications errors in noisy environments.
- **Setting the TX Config value** – The TX Config setting determines how often the GASMAX/TX transmits the large data packet that contains configuration data. The default is 60 minutes. Decreasing the TX Config interval will slightly increase battery power usage.
- **Setting RF Handshaking** – If RF Handshaking is ON, the Wireless Site Manager will actively acknowledge each transmission from the GASMAX/TX. If an acknowledge signal is not received by the GASMAX/TX, the transmission will be repeated up to three times. RF Handshaking ON will increase wireless reliability but may reduce battery life if transmissions must be repeated.

**NOTE: RF HANDSHAKING CAN ONLY BE USED IF THE GASMAX/TX IS TRANSMITTING TO A SINGLE WIRELESS SITE MANAGER OR RECEIVER/CONTROLLER.**

## **ALARM SETUP**

When used with third-generation products like the C2/TX Wireless Site Manager, GDS-98 Wireless System Manager or GDS-95 Alarm Station, the **alarm settings programmed into the GASMAX/TX will directly trigger the alarm condition**. Alarm indicators can be set to activate above or below a given engineering units set point. Alarm processing will trigger an alarm condition when the input exceeds the programmed value, and includes hysteresis to keep the alarm from rapidly switching ON and OFF if the input remains close to the programmed alarm value.

If the GASMAX/TX is used with second-generation legacy products such as the C2 *Quad Protector* Receiver / Controller, C1 *Protector* Receiver / Controller or C64 *Protector* Receiver / Controller, the remote controllers **ignore the alarm status bits** and use **broadcast gas levels to trigger alarms**. In this case, alarm level data must be manually programmed at the receiver / controller.

## SENSOR REPLACEMENT

If a sensor shows FAULT, does not respond to gas or can no longer be calibrated, it should be replaced. GASMAX/TX monitors use GDS Corp type 10-97xx electrochemical sensors or ultra-low-power infrared sensors, where the XX is the gas type shown in Specifications. The range value should also be specified when ordering replacement sensors. For example, a replacement H<sub>2</sub>S sensor for 0-100 ppm would be “10-9715-R0100”.

To replace a sensor, follow these steps:

1. Turn off the GASMAX/TX by accessing the *Device Setup – Turn Power Off* menu or holding the magnet over the NEXT key until the display shows “EDIT at Accept, then pressing the EDIT key.
2. Unscrew the sensor head cover. If unable to open the cover by hand, use a Sensor Head Replacement Tool (p/n 10-0187).
3. Remove the old sensor by pulling straight down.  
**NOTE: DO NOT TRY TO UNSCREW THE SENSOR. PULL STRAIGHT DOWN.**
4. Carefully install the replacement sensor by aligning the arrow on the sensor with the arrow engraved on the sensor head. Push straight up until the sensor connector seats firmly into the connector.
5. Reinstall the sensor head cover by CAREFULLY screwing the cover onto the sensor head.  
**NOTE: IF THE SENSOR FALLS OUT OF THE SENSOR HEAD DURING THIS STEP, IT CAN BE DAMAGED. USE CAUTION WHEN REINSTALLING THE SENSOR HEAD COVER.**
6. Turn the GASMAX/TX ON by holding the magnet over the UP/ON key until the welcome screen appears on the display.

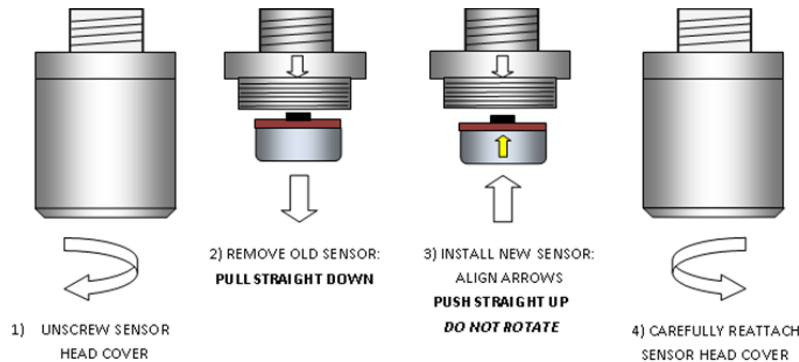

**Figure 10-3: GASMAX/TX Sensor Replacement**

Local Smart Sensors are automatically recognized by the GASMAX/TX and the Smart Sensor information screen should appear immediately after the installation of a local Smart Sensor. If the sensor is the same gas type as was previously installed, the sensor's calibration data will be uploaded into the GASMAX/TX. All other parameters stored in the GASMAX/TX will be retained.

GASMAX/TX units can be reconfigured for different sensors by simply installing a different type compatible sensor. If a new sensor TYPE is installed, the Smart Sensor identification screen will appear, followed by the SENSOR MISMATCH message and the user will be given the opportunity to confirm the new sensor type. If the user activates the EDIT key, all data stored in the new sensor's database – including range, tag name, cal span value, engineering units and alarm levels – will replace the current settings.

## **SENSOR REPLACEMENT – REMOTE SENSORS**

To replace a remote sensor, follow these steps:

1. Turn off the GASMAX/TX by accessing the *Device Setup – Turn Power Off* menu or holding the magnet over the NEXT key until the display shows “EDIT at Accept, then pressing the EDIT key.
2. Unscrew the remote sensor head cover. If unable to open the cover by hand, use a Sensor Head Replacement Tool (p/n 10-0187).
3. Remove the old sensor by pulling straight down.  
**NOTE: DO NOT TRY TO UNSCREW THE SENSOR. PULL STRAIGHT DOWN.**
4. Carefully install the replacement sensor by aligning the arrow on the sensor with the arrow engraved on the sensor head. Push straight up until the sensor connector seats firmly into the sensor connector.
5. Reinstall the sensor head cover by CAREFULLY screwing the cover onto the sensor head.  
**NOTE: IF THE SENSOR FALLS OUT OF THE SENSOR HEAD DURING THIS STEP, IT CAN BE DAMAGED. USE CAUTION WHEN REINSTALLING THE SENSOR HEAD COVER.**
6. Turn the GASMAX/TX ON by holding the magnet over the UP/ON key until the welcome screen appears on the display.

## **NORMAL MAINTENANCE**

Normal maintenance for the GASMAX/TX primarily involves battery replacement and periodic calibration on standard intervals. GDS Corp recommends calibration at least every three months, or more often if temperature extremes, vibration, the presence of incompatible gases or other environmental factors may accelerate the deterioration of the sensor element. Calibration should also include inspections for clogged or wet sensor heads, cracked or damaged enclosures and water incursion inside conduit or junction boxes.

## 11 USER MENUS

The GASMAX/TX Main Menu tree is shown below. To access the Main Menu, swipe the magnetic wand over the EDIT key. Use the UP and DN keys to select an item and press EDIT. Use NEXT to exit a menu.

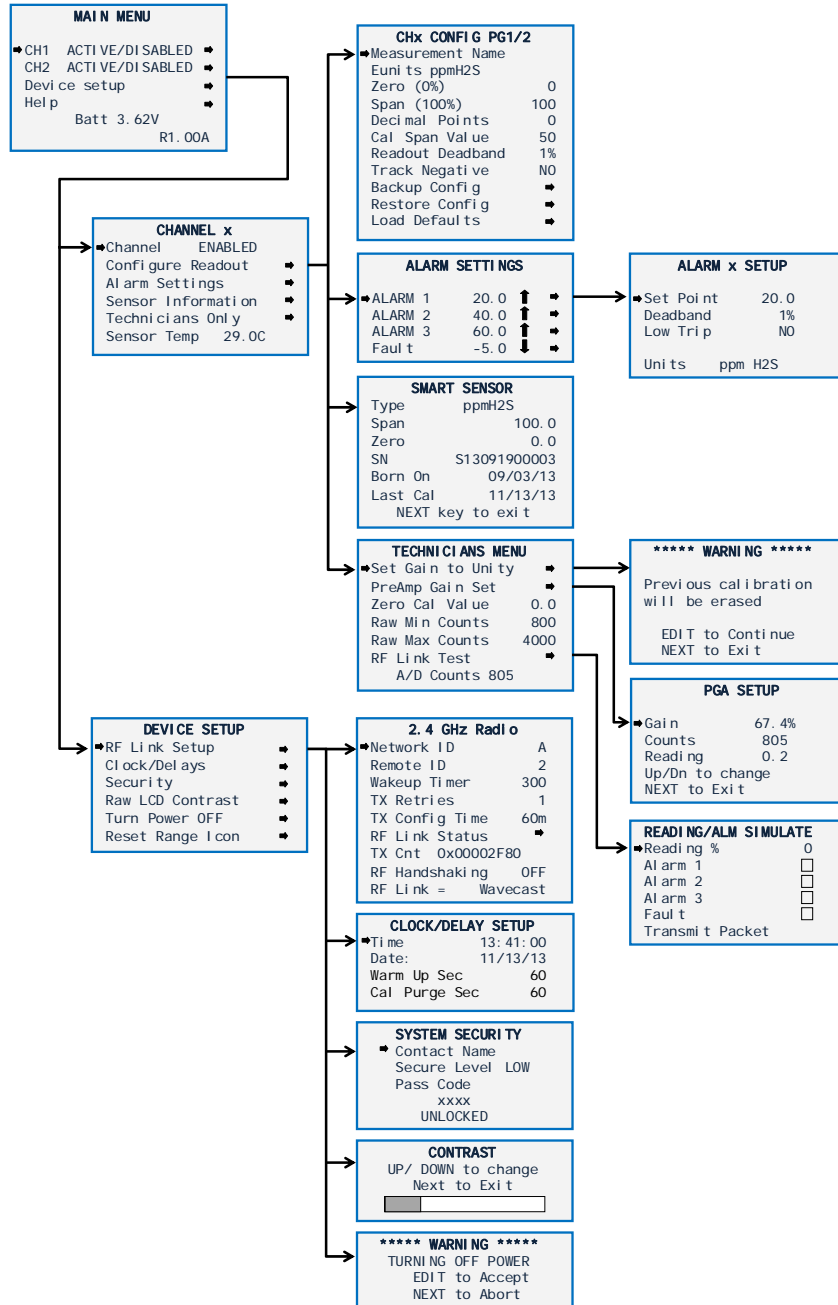

Figure 11-1: GASMAX/TX Main Menu Tree

## CHANNEL CONFIGURATION MENU

The Channel Configuration menu contains settings that are unique to each channel. There are two channels and each menu contains identical entries.

**NOTE: WHEN EDITING CHANNEL INFORMATION, MAKE SURE TO SELECT THE CORRECT CHANNEL MENU.**

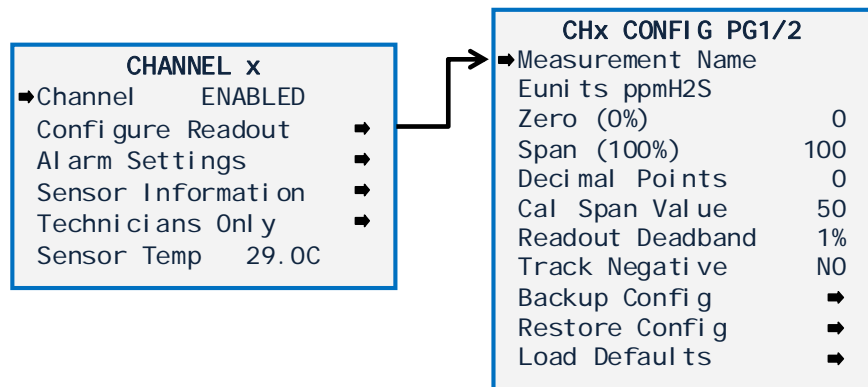

Figure 11-2: Channel Configuration Menu

**CHANNEL ENABLED / DISABLED** – Channels should only be enabled if a sensor is attached.

**SENSOR TEMP** – Shows the current sensor temperature.

**MEASUREMENT NAME** may be edited to contain any 16-character field and is typically used to describe the monitored point by user tag number or other familiar terminology. To modify the existing setting, press the EDIT key when the cursor is pointing to the entry. Use the UP or DN keys to change the character, and the NEXT key to move to the next character. Press EDIT again when done.

**EUNITS** (engineering units) may have up to a 10 character ASCII field. Many common gases have pre-configured Eunits based upon the sensor type and each may be edited in this menu.

**ZERO (0%)** defines the reading to be displayed when the input is at 0%.

**SPAN (100%)** defines the reading to be displayed when the input is at 100%. The highest reading allowed is 9999 including negative polarity sign. Polarity is only indicated for negative readings.

**DECIMAL POINTS** set the resolution of the LCD readings and may be set for 0, 1 or 2. For example, ZERO readings for 0, 1 & 2 decimal points displays as “0”, “0.0” & “0.00”.

**CAL SPAN VALUE** sets the engineering units value of the calibration gas. GDS Corp recommends that the calibration gas value be between 25% and 75% of full scale. Calibrating at 100% of scale is not recommended.

**READOUT DEADBAND** forces low values to continue to read zero. This is useful when there are small amounts of background gases that may cause fluctuating readouts. The highest amount of deadband allowed is 5%.

**TRACK NEGATIVE** allows the display to show negative values when set to “YES”. This can be helpful when troubleshooting sensor problems. The default setting is “NO” and forces the display to read “0” if the sensor value drops below zero. However, negative sensor outputs will always cause the Fault alarm to trip.

**BACKUP CONFIG** allows users to store the entire current GASMAX/TX menu database into non-volatile memory for restoration later if incorrect values are accidentally entered or uploaded.

**RESTORE CONFIG** restores the GASMAX/TX menu database to the values from the most recent Backup Config. The special keystroke sequence of 4 consecutive UP keys is also required to perform backup and restore operations.

**LOAD DEFAULTS** restores factory default settings.

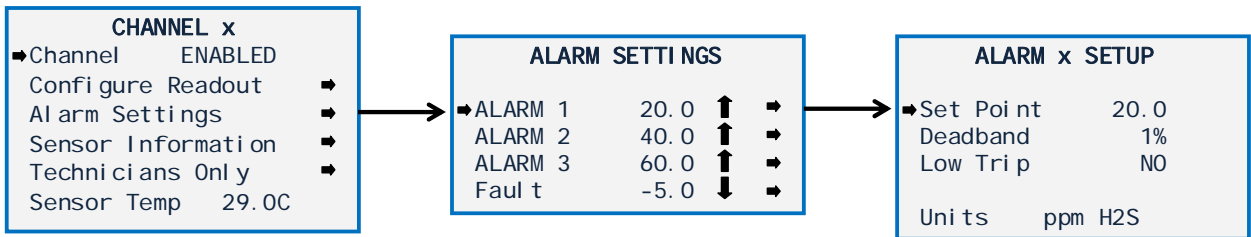

Figure 11-3: Alarm Settings Menu

The Alarm Settings page covers the Alarm 1, 2 and 3 menu items. Alarm 1, Alarm 2, Alarm 3 and Fault menus are identical and are therefore described only once in this section. For the GASMAX/TX, the alarm settings not only control the status of the indicator LEDs, but also cause alarm conditions to occur in the GDS-95 Wireless Alarm Station and C2/TX Wireless Site Monitor.

**SET POINT** enters the engineering unit value where the alarm trips. It may be negative and trip when monitored values fall out of range in this direction. Fault has a default setting of negative 10 with Low Trip set for YES. It is important to adjust this value when the transmitter’s span value is set for another value other than 100. For example, a typical span setting for monitoring oxygen level is 25 therefore the fault level value should be adjusted to -2.5 which is equal to negative 10% of full scale.

**DEAD-BAND** has a minimum value of 1% and a maximum value of 10%. It is useful for preventing alarm cycling when the monitored value is hovering around the set point. EXAMPLE: With a range of 0-100 ppm, if deadband equals 5% and the set point is 20 ppm, after tripping at 20 ppm the value must drop below 15 ppm to reset.

**LOW TRIP** set to YES causes the alarm to trip as the value falls below the set point.

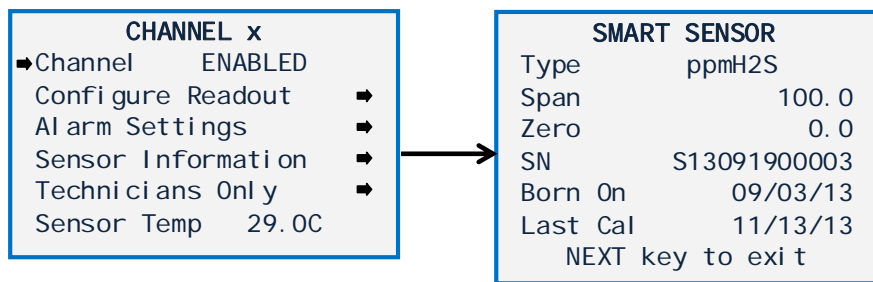

**Figure 11-4: Smart Sensor Information Menu**

The Sensor Information page covers settings associated with Smart sensors. Users can review information contained in the Smart Sensor database. Values cannot be user-modified.

**TYPE** indicates what kind of input or sensor the GASMAX/TX is configured to accept and is typically pre-configured at the factory. When installed, Smart Sensors upload sensor type and other data to the GASMAX/TX and this data may be viewed on the SMART SENSOR information screen.

**SPAN** displays the programmed value for 100% of range. Factory programmed.

**ZERO** displays the programmed value for 0% of range. Factory programmed.

**SERIAL NUMBER** - displays the unique sensor serial number.

**BORN ON** displays the date when the sensor was originally configured at the factory.

**LAST CAL** displays the date of the most recent calibration.

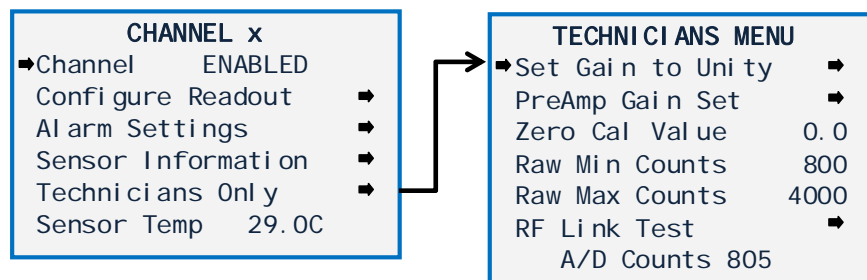

**Figure 11-5: Technicians Menu**

**ZERO CAL VALUE** should always be set to “0”.

**RAW MIN / RAW MAX COUNTS** – determines the range of the 12 bit analog to digital converter. Raw Min Counts represents 0% of scale and Raw Max Counts represents 100% of scale. Under certain conditions, these counts values can be adjusted to remove excessive offset or increase the apparent gain of the sensor. Raising or lowering the value of the Raw Min Counts will adjust the sensor ‘zero’ point, and reducing the Raw Max Counts will amplify the sensor’s output by reducing the range between zero and span.

**NOTE: ADJUSTING THE RAW MIN OR RAW MAX COUNTS SHOULD ONLY BE DONE BY TECHNICIANS FAMILIAR WITH THE GASMAX/TX GAS MONITOR.**

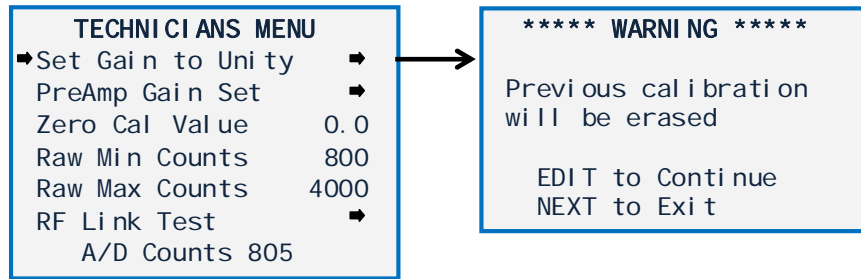

Figure 11-6: Set Unity Gain Menu

**SET GAIN TO UNITY** sets the Gain and Offset values to 1.000 and 0.000 respectively. This clears any previous calibration data and is useful in troubleshooting if sensor readings appear to be incorrect.

**WARNING: A FULL CALIBRATION SHOULD ALWAYS BE PERFORMED AFTER A SET GAIN TO UNITY COMMAND.**

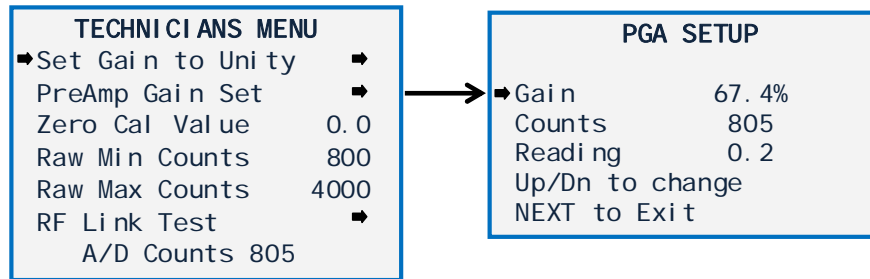

Figure 11-7: Preamp Gain Set Menu

**PREAMP GAIN SET** Gas sensors have a very wide range of output levels and the PGA gain parameter is used to match the sensors' output to the Smart Sensor's signal conditioning circuitry. Each type of sensor has a nominal gain value that is preset at the factory. Altering the PGA gain value resets the calibration Gain and Offset values to their default values of 1.000 and 0.000. The current PGA gain value is shown in percent and can be increased or decreased by pressing the UP or DOWN keys.

**WARNING: A FULL CALIBRATION SHOULD ALWAYS BE PERFORMED AFTER ANY CHANGE IN THE PREAMP GAIN SETTING.**

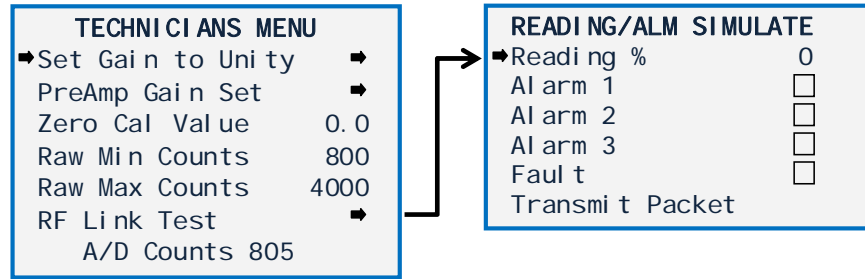

Figure 11-8: RF Link Test Menu

**RF LINK TEST** The RF Link Test is a diagnostics tool which allows the user to cause the GASMAX/TX to transmit simulated readings of 0%, 25%, 50%, 75% and 100% of scale without actually applying gas. Checking the check box associated with each alarm setting can also be used to force the transmission of a data packet with the corresponding alarm bit set. Select the value or alarm condition and select the TRANSMIT PACKET command to perform the function.

## DEVICE SETUP MENU

The Device Setup menu contains settings that are unique to the detector itself.

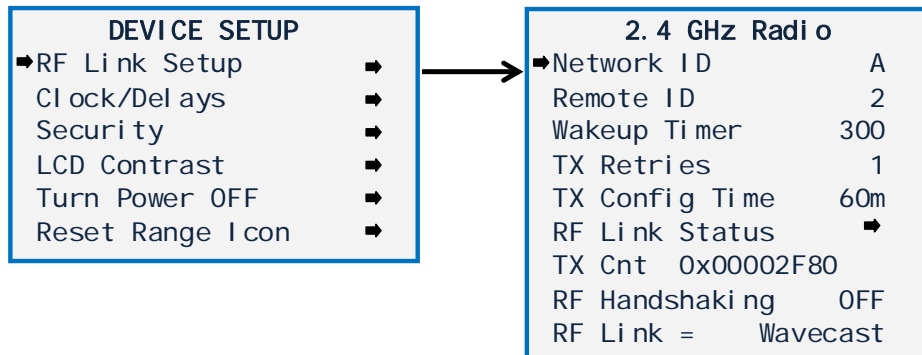

Figure 11-9: Radio Setup Menu (2.4 GHz)

The RF Link Setup menu is used to configure the radio modem in the GASMAX/TX. There are two similar menus, one for 900 MHz radios and another for 2.4 GHz radios.

**NETWORK ID** may be set from "A" through "Z" and assigns the pseudo-random radio frequency hopping pattern and system identifier. A transmitter will not go In Range of or communicate with another transmitter operating with a different Network Identifier. Different Network Identifiers can be used to prevent radios in one network from listening to transmissions of another. Installations having more than one Server network should also have different Network Identifiers for each network

**DEVICE ID** may be set from 1-255 and acts as the device address for this particular GASMAX/TX.

Controller channels receiving this monitor’s data must also be configured with this matching Remote ID address.

**WAKE UP TIMER** determines how often the GASMAX/TX sends a small data packet when there are no alarms present and when the gas level remains constant. The interval can be set to a value between six seconds and 300 seconds (default value). Decreasing the wakeup timer will use more power and decrease battery life, but allow remote receivers to determine a loss of signal condition more rapidly.

**TX RETRIES** allows up to 5 consecutive repeats of every transmission. The default setting is 1 and should be increased only if there is no other way to establish a reliable transmission link.

**TX CONFIG TIME** determines how often the GASMAX/TX transmits a large data packet that contains all the channel configuration parameters. This interval can be set for a value between 15 and 60 minutes. Default is 60 minutes.

**RF LINK STATUS** opens a special window that shows real-time status for battery voltage and ‘in range’ condition.

**TX COUNT** keeps track of the number of data packets sent by the GASMAX/TX. The counter is 32 bit binary and can count up to 4.2 million transmissions.

**RF HANDSHAKING** determines whether the remote receiver is expected to return a ‘data received’ message. If set to “OFF”, the GASMAX/TX broadcasts the same packet three times in quick succession. If set to “ON” the GASMAX/TX broadcasts a single copy of the data packet and waits for a reply from the system server. **NOTE: RF HANDSHAKING SHOULD ONLY BE USED IF THERE IS JUST ONE RECEIVER IN THE NETWORK.**

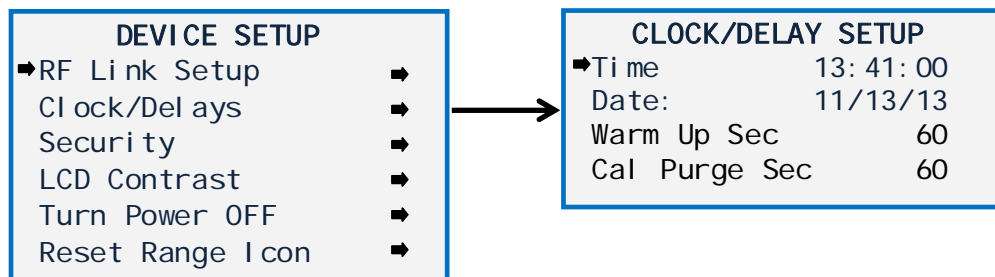

**Figure 11-10: Clock / Delay Menu**

The GASMAX/TX is equipped with a crystal-controlled, battery-backed real-time clock that maintains local Time and Date. These values are factory preset to US Central Time and should be reset to correctly match the current time zone during installation to make sure that time-stamped Event Log entries are correct.

**TIME** adjusts time of day in hours, minutes and seconds. Time is entered in 24 hour format. The GASMAX/TX will not adjust the clock to compensate for Daylight Savings Time.

**DATE** adjusts date in month, day and two-digit year.

**WARM UP DELAY** sets the amount of time from power-on until the 4-20mA output signal begins to track the sensor output. Default setting is 60 seconds. Maximum value is 255 seconds.

**CAL PURGE DELAY** sets the amount of time from the completion of span calibration until the 4-20mA output signal restarts tracking the sensor output. The default setting is 60 seconds and the maximum value is 255 seconds.

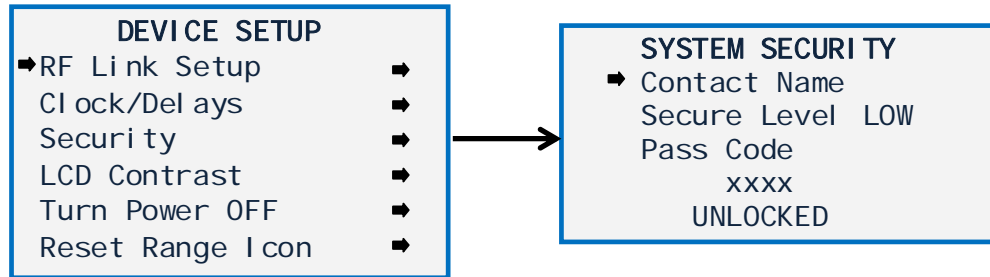

Figure 11-11: Security Menu

**CONTACT NAME** is a 12 character ASCII field available for displaying a phone # or name of personal who knows the Pass Code. Lost Pass Codes may be recovered by entering the locked security menu and holding the UP key for 5 seconds. The 4-digit code appears near the bottom of the screen.

**SECURE LEVEL** sets LOW, HIGH or OFF modes. A LOW level allows CAL MODE sensor calibrations but requires the 4-digit Pass Code prior to altering menus. HIGH level locks the entire menu database and the CAL Mode until the correct Pass Code is entered. LOW and HIGH security levels always allow static viewing of configuration menus.

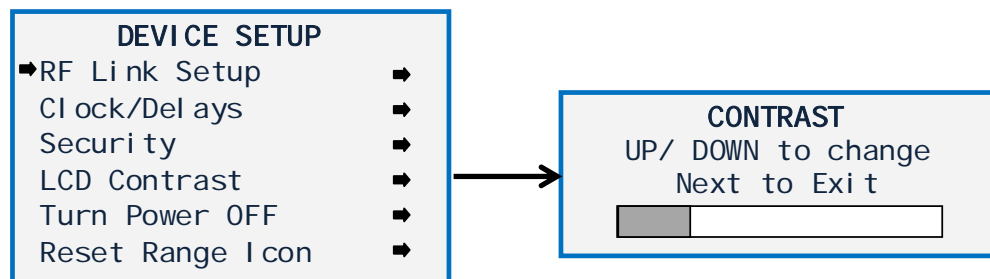
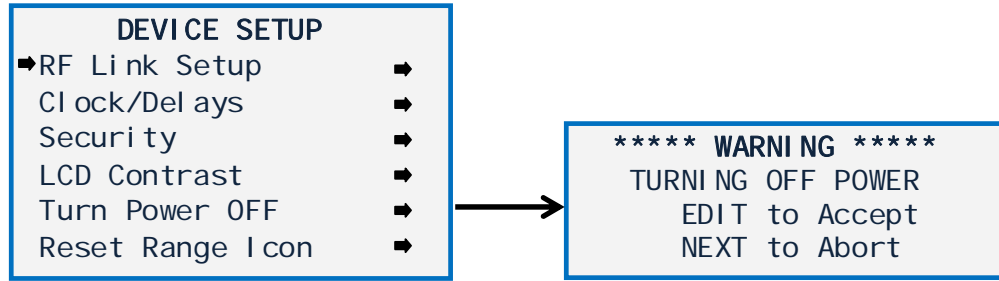

Figure 11-12: LCD Contrast Menu

**LCD CONTRAST** Select the LCD contrast command and use the UP or DOWN to adjust the contrast of the LCD display.



**Figure 11-13: Power Off Menu**

**TURN POWER OFF** To turn the GASMAX/TX off, select the *Device Setup – Turn Power Off* menu or hold the magnet over the NEXT key until the display shows “EDIT to Accept, and then press the EDIT key.

## 12 TROUBLESHOOTING GUIDE

### SENSOR INDICATES FAULT OR OVERRANGE

- Certain toxic sensors indicate fault or over-range at power up and quickly drift towards zero. This is normal behavior.
- Examine the sensor for moisture or discoloration. Replace sensor if wet or discolored.
- Inspect sensor cable and junction box for moisture or standing water. Replace cable or junction box interface boards if wet or damaged.
- If no moisture, discoloration or damage is found, sensor may be at the end of its useful life. Replace sensor.
- Toxic sensors left unpowered for more than 3 months are subject to accelerated degradation and may demonstrate a permanent loss of sensitivity.

### SENSOR WILL NOT ZERO

- Background gas is present. Use 'zero air', a mixture of oxygen and nitrogen to zero the sensor.
- Sensor output drifted above calibration maximum limit or drifted below fault limit. Sensor is defective and should be replaced.

### GASMAX/TX EXHIBITS UNUSUAL OR UNEXPECTED BEHAVIOR

- Reload sensor defaults (see )
- Perform a "Cold Boot" to re-initialize the entire system. To perform a Cold Boot, hold the magnet over the UP/ON key until the display reads "Release Key", then slide the magnet over the EDIT key.

**NOTE: COLD BOOT CLEARS ALL DEVICE SETTINGS, INCLUDING NETWORK IDENTIFIER AND DEVICE ID. BE SURE TO RECORD THESE VALUES BEFORE PERFORMING THE COLD BOOT PROCEDURE.**

### GASMAX/TX DISPLAY BLANK

- Turn the GASMAX/TX on by holding a magnetic wand over the UP/ON key
- Open enclosure and inspect battery for proper installation.
- Replace battery – NOTE: BE SURE TO OBSERVE PROPERLY POLARITY

### GASMAX/TX AND C2/TX WIRELESS SITE MANAGER DISPLAYED VALUES

#### DON'T MATCH

- Verify viewing proper channel
- Verify C2/TX "device ID" and GASMAX/TX "device ID" match

## **WIRELESS SITE MANAGER DISPLAYS COMM ERROR FOR A SINGLE GASMAX/TX**

- Network Identifier does not match.
- GASMAX/TX device ID and WSM assigned channel device ID do not match.
- Distance between gas monitor and WSM too great for reliable communications
- WSM beacon not set for SERVER if primary network manager
- Antenna connection compromised or antenna broken.

## **WIRELESS SITE MANAGER DISPLAYS COMM ERROR FOR ALL GASMAX/TX**

- Network Identifiers do not match.
- No synchronizing beacon signal. Verify C2/TX RF Mode = SERVER and verify GASMAX/TX “Server in Range” icon displayed.
- RF signal attenuated. Check C2/TX WSM antenna connection, cable and remote antenna (if installed). Place a GASMAX/TX in close proximity with the C2/TX WSM and check for proper operation.

## 13 SPARE PARTS

### DISPLAY & ENCLOSURE

**Display:**

10-0404	GASMAX/TX Display (no radio)
1000-2188	900 MHz radio module
1000-2454	2.4 GHz radio module

**Antenna Coupler:**

10-0295	Antenna coupler (RP-TNC)
1200-0482	C1D1 rated antenna coupler

**Yellow Enclosure:**

10-0160	GASMAX Enclosure
---------	------------------

**Battery PCB:**

10-0407	Battery PCB
1000-2721	Replacement 3.6V Battery

**Sensor Head Assembly:**

10-0247	For standard gases
10-0247F	For reactive gases
Note: Does not include sensor	

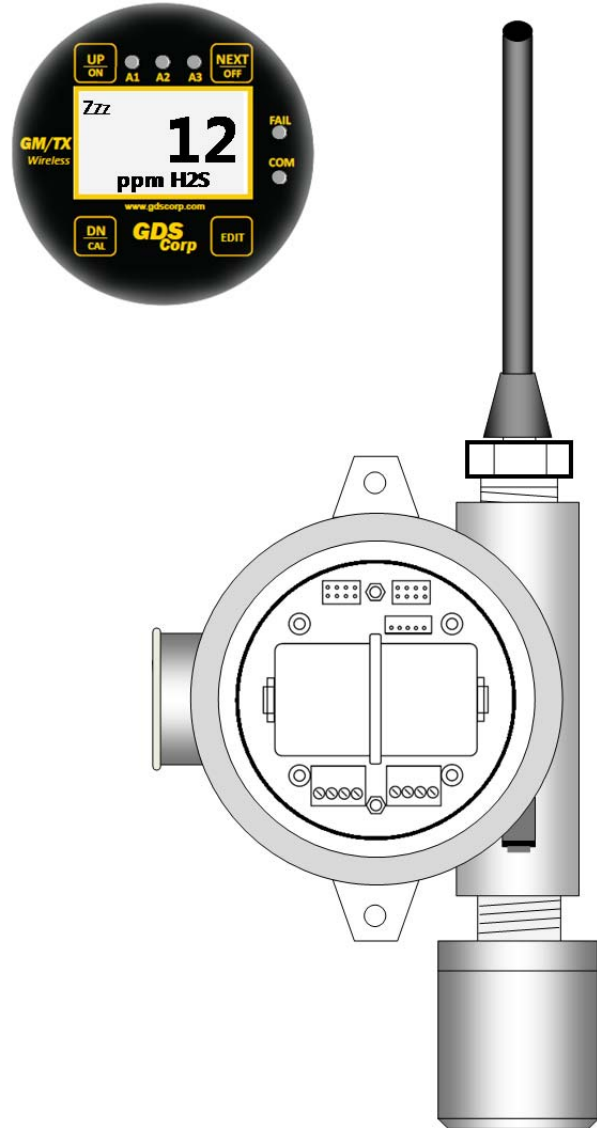
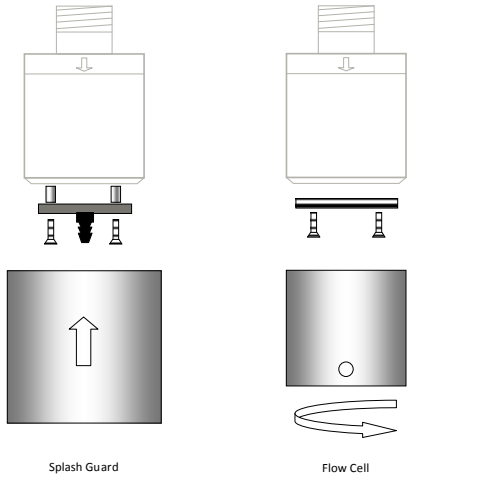

Figure 13-1: GASMAX/TX + Local Sensor Spare Parts

### SENSOR HEAD ACCESSORIES



#### Sensor Head Splash Guard

10-0198 Splash Guard (Fits all sensor heads)

#### Sensor Head Flow Cell

10-0205 Flow Cell (1/8" NPT compression fittings)

10-0205s Other (specify)

Figure 13-2: GASMAX Sensor Head Splash Guard & Flow Cell

### SENSOR SEPARATION KIT

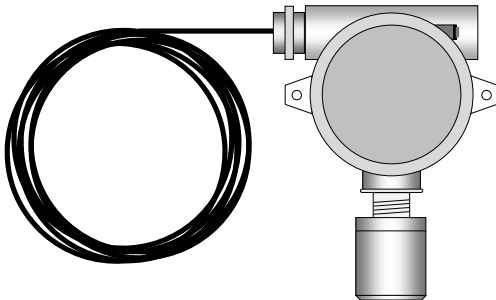

#### Remote Sensor Head Assembly:

20-0162 Remote Toxic / Combustible

20-0123 Remote Toxic / Reactive Gas

Note: Does not include sensor

Figure 13-3: GASMAX/TX Remote Sensor Separation Kit

## 14 DRAWINGS AND DIMENSIONS

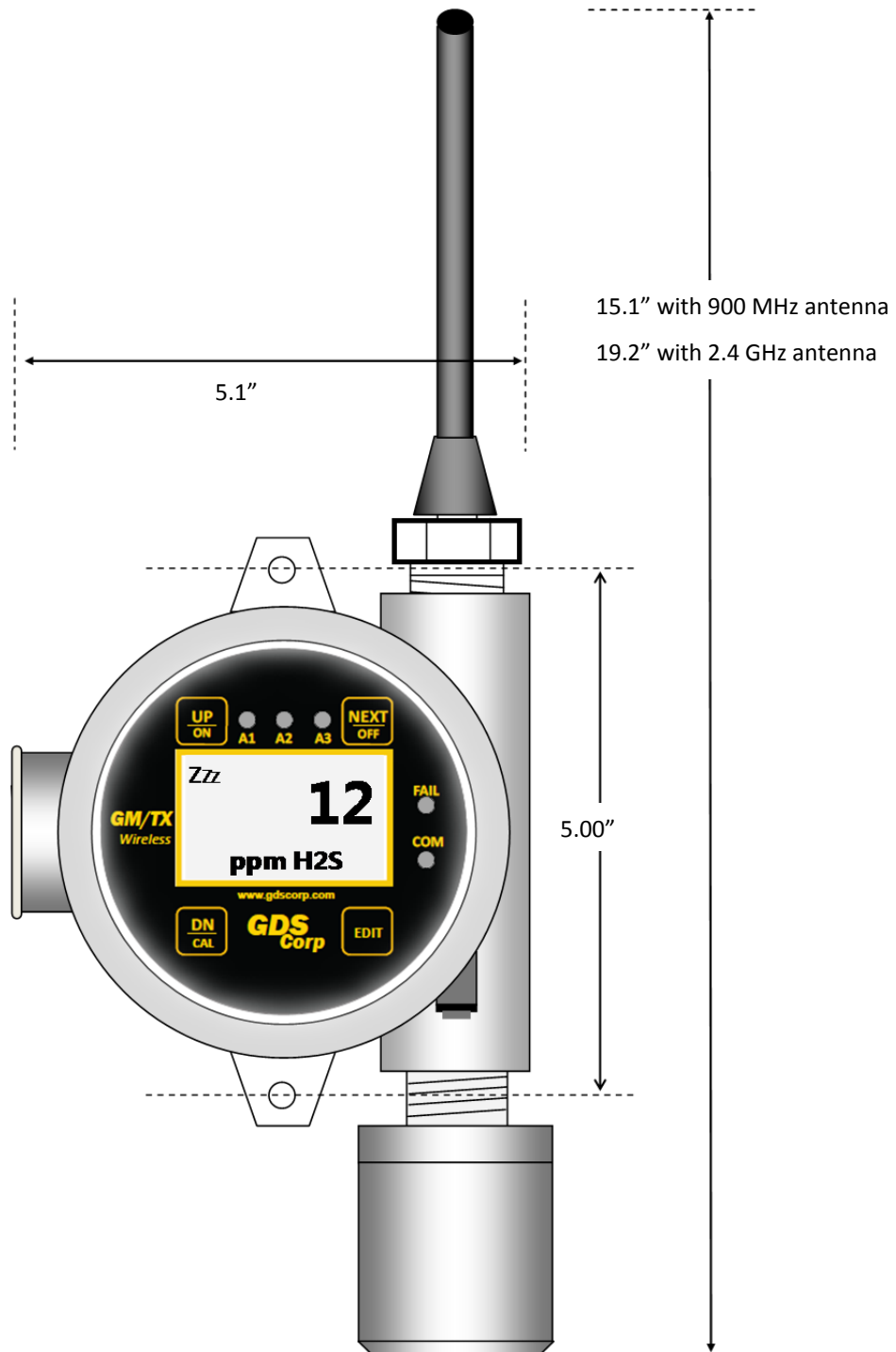

Figure 14-1: GASMAX/TX Dimensions (Single Local Sensor)

## 15 NETWORK PARAMETERS

The set of Network Identifiers used by the GASMAX/TX specify a combination of frequency hopping pattern, frequency band, System ID value and whether or not the data is encrypted using a proprietary software-based algorithm.

NETWORK ID	Hop Pattern	System ID	Data Encrypted?	900 MHz Band	2.4 GHz Band	Legacy Compatible?
A	1	1	No	902-928 MHz	2.402 - 2.478 GHz	Yes
B	2	2	No	902-928 MHz	2.402 - 2.478 GHz	Yes
C	3	3	No	902-928 MHz	2.402 - 2.478 GHz	Yes
D	4	4	No	902-928 MHz	2.402 - 2.478 GHz	Yes
E	5	5	No	902-928 MHz	2.402 - 2.478 GHz	Yes
F	6	6	No	902-928 MHz	2.402 - 2.478 GHz	Yes
G	7	7	No	902-928 MHz	2.402 - 2.478 GHz	Yes
H	8	8	No	902-928 MHz	2.402 - 2.478 GHz	Yes
I	9	9	No	902-928 MHz	2.402 - 2.478 GHz	Yes
J	10	10	No	902-928 MHz	2.402 - 2.478 GHz	Yes
K	11	11	No	902-928 MHz	2.402 - 2.478 GHz	Yes
L	12	12	No	902-928 MHz	2.402 - 2.478 GHz	Yes
M	13	13	YES	902-928 MHz	2.402 - 2.478 GHz	No
N	14	14	YES	902-928 MHz	2.402 - 2.478 GHz	No
O	15	15	YES	902-928 MHz	2.402 - 2.478 GHz	No
P	16	16	YES	902-928 MHz	2.402 - 2.478 GHz	No
Q	17	17	YES	902-928 MHz	2.402 - 2.478 GHz	No
R	18	18	YES	902-928 MHz	2.402 - 2.478 GHz	No
S	19	19	YES	902-928 MHz	2.402 - 2.478 GHz	No
T	20	20	YES	902-928 MHz	2.402 - 2.478 GHz	No
U	21	21	YES	902-928 MHz	2.402 - 2.478 GHz	No
V	22	22	YES	902-928 MHz	2.402 - 2.478 GHz	No
W	23	23	YES	902-928 MHz	2.402 - 2.478 GHz	No
X	24	24	YES	902-928 MHz	2.402 - 2.478 GHz	No
Y	25	25	YES	902-928 MHz	2.402 - 2.478 GHz	No
Z	26	26	YES	902-928 MHz	2.402 - 2.478 GHz	No

Figure 15-1: GDS Corp Network Identifiers