



MODEL GDS-49 TOXIC / OXYGEN 2-WIRE 4-20mA TRANSMITTER / C1 INSTALLATION DRAWING

This Installation Drawing is a supplement to the C1 "Protector" Controller manual and should be used when interfacing GDS-49 Sensor Transmitters to the C1. The Global Detection Systems Corp. GDS-49 2-Wire 4-20mA Transmitter is typically used with our C1 Controller as shown below. GDS-49's have a 3/4" NPT threaded bushing for mounting to a user supplied vibration free fixture. Be sure to leave enough room around the GDS-49 to fit the cal-cup adaptor required for calibrations (Figure 2). Field wiring size between the GDS-49 and the C1 should be at least 20 AWG and kept away from noise sources such as motors and relays. Field wiring will need to be "spliced" onto GDS-49 wires using the appropriate user supplied wire nuts, crimps or junction box.

IMPORTANT: FOLLOW CORRECT ELECTRICAL CODE INSTALLATION PRACTICES FOR YOUR AREA CLASSIFICATION!

The two non-polar white wires from the GDS-49 land on a C1 Controller channel's EXC and HI terminals; with the LO terminal left unused (Figure 1). Repeat these connections from each GDS-49 into each C1 channel. C1 channels may be preconfigured for specific GDS-49 gas types or ranges. If different type GDS-49's are being used, be sure to connect each type to its correct C1 channels.

START-UP & STABILIZATION PERIOD:

With all wiring connected properly, apply power to the C1 and it will power the GDS-49's. Sensor Gas types vary greatly as to how much stabilization time is required. BIAS sensors such as Ammonia, Ethylene Oxide and Hydrogen Chloride require at least 48 hours to stabilize before attempting to calibrate. GDS-49 outputs will be very high initially, then gradually decrease to their correct values during the stabilization period.

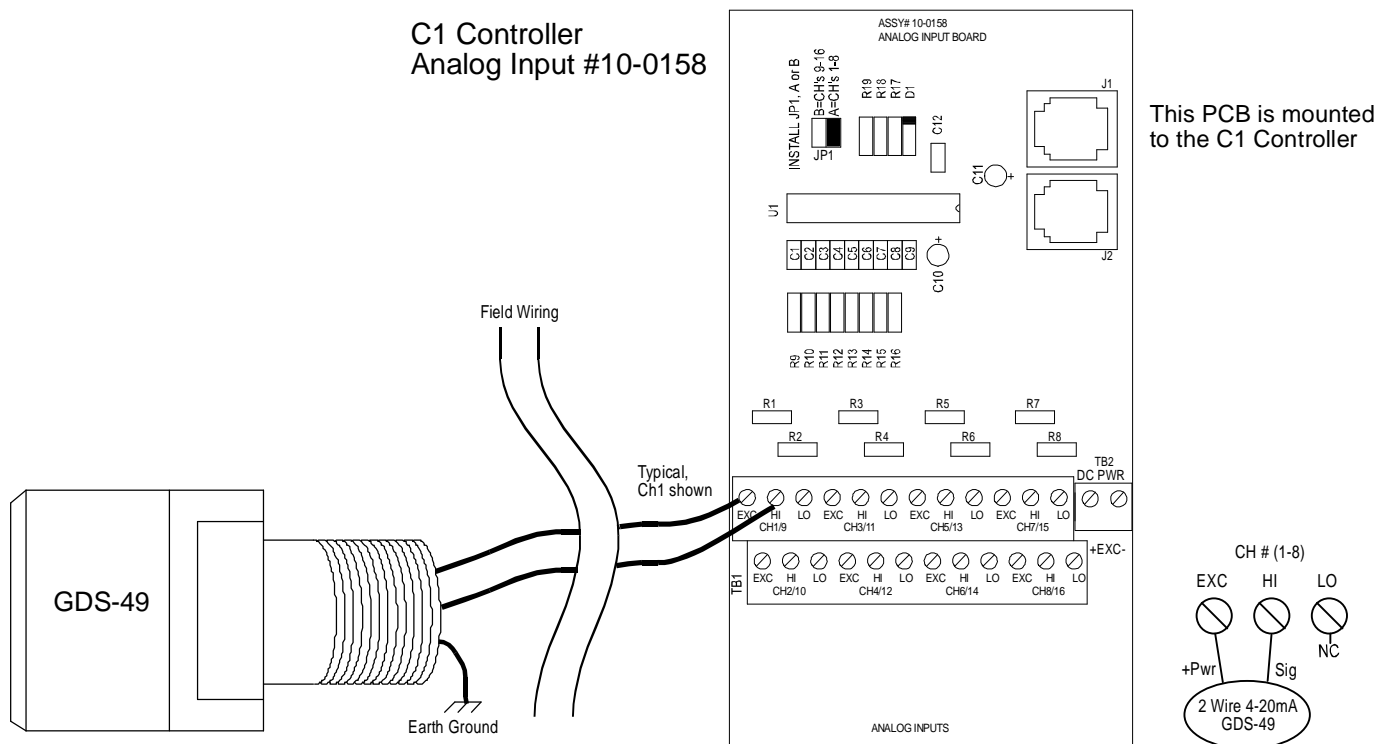

FIGURE 1

CALIBRATION:

AFTER THE STABILIZATION PERIOD IS COMPLETED, each RM-49 should be calibrated with its correct SPAN gas value. If it can be verified that ambient air is free of target gases, it may be used for ZERO calibration. Otherwise, use a cylinder of ZERO air to ZERO each RM-49. Place the C1 Controller into the Cal-Mode as follows:

From any C1 data display, press EDIT, point to channel to calibrate, press EDIT again, point to CALIBRATE, press EDIT again.

IMPORTANT: READ & UNDERSTAND SECTIONS 1 & 2 OF C1 MANUAL!

Connect the Cal-Gas as shown in Figure 2 on this sheet. Refer to section 2.2.7 of the C1 manual for correct use of Cal-Mode. Be sure Cal Span Set-Points match actual gas being used.

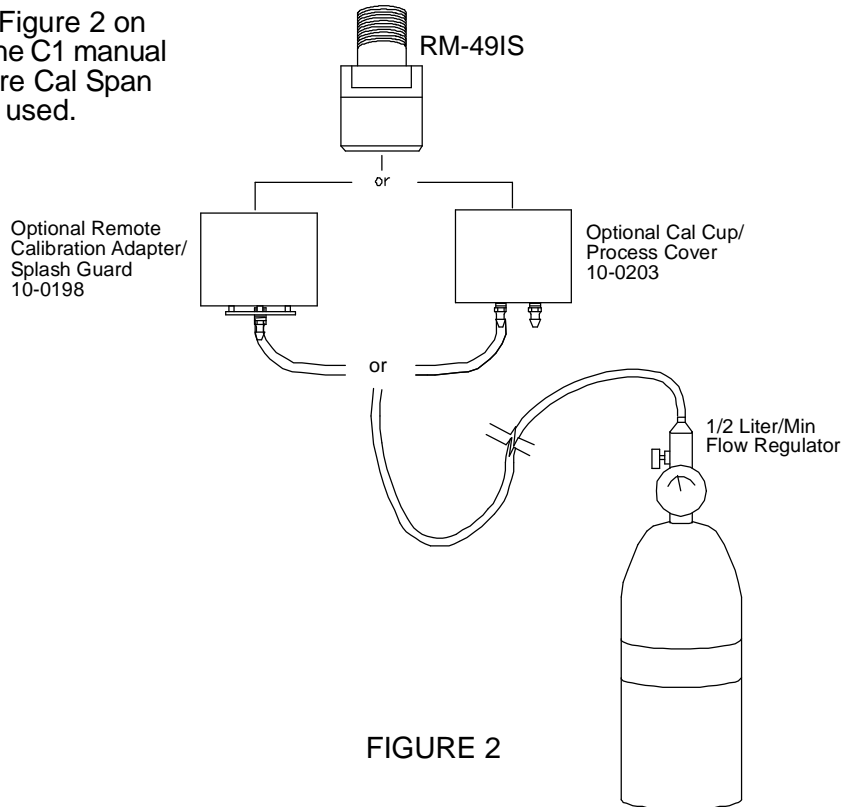

FIGURE 2

MECHANICAL

3/4" NPT

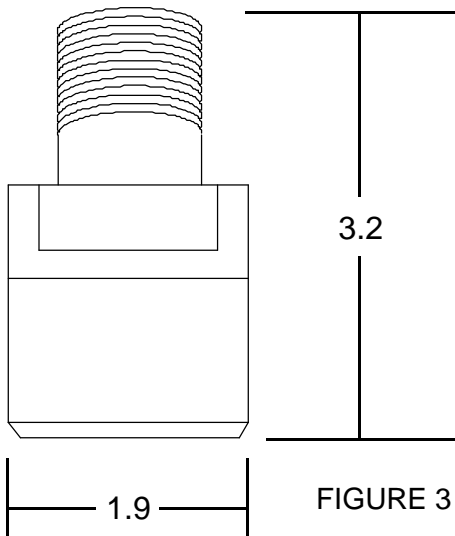
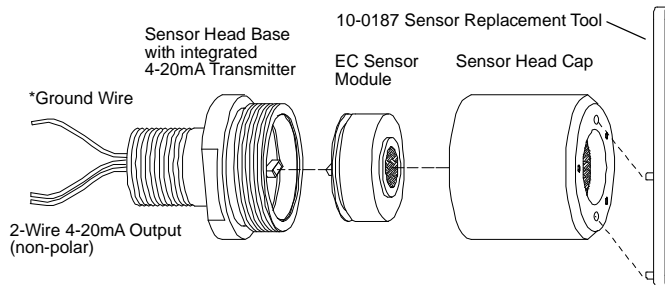

FIGURE 3

ALL DIMENSIONS IN INCHES

SENSOR REPLACEMENT

Use the 10-0187 Tool to remove the Sensor Head Cap. Unplug old EC Sensor Module. Plug in new correct EC Sensor Module. Replace Sensor Head Cap and tighten.



*Ground Wire not included on non-metallic intrinsically safe models.

FIGURE 4



2513 Hwy. 646
Santa Fe, TX 77510

TEL: (409) 927-2980 FAX: (409) 927-4180
WEB: <http://www.gdscorp.com>