

Model M1 Gas Monitor

Toxic / O₂ or Combustible Gas Detection for Hazardous Locations

- * CSA certified for explosion proof installations with stainless steel sensor head
- * Aluminum sensor head available for highly reactive gases
- * Continuous digital LCD readout in engineering units
- * Highly visible FAULT LED
- * Non-intrusive one-person calibration for easy maintenance
- * Power-up and post-calibration delays eliminate false alarms
- * Options include 5A relays, isolated 4-20mA output or MODBUS
- * Offset and gain readings allow tracking of sensor degradation
- * Fault supervision circuitry detects failed sensor & transmits warning
- * Setup in hazardous area requires only simple magnetic wand
- * CSA Certified C22.2 No. 152 for combustibles & ISA S82.02



The Model M1 Gas Monitor detects combustibles, toxic or oxygen gas levels and displays calibrated values in engineering units on a 3 1/2 digit LCD readout. Easily replaceable sensors and options that include MODBUS®, 5A form C relays and isolated 4-20mA outputs enable the Model M1 gas monitor to satisfy the most demanding gas detection applications.

Non-intrusive magnetic zero / span controls enable one-person calibration without opening the enclosure or declassifying the hazardous area. A built-in one-minute post-calibration and power-up delay locks the 4-20mA output at 4mA to eliminate false alarms due to calibration span gas or sensor stabilization. During the actual

Hydrogen Sulfide
Oxygen Deficiency
Carbon Monoxide
Hydrogen Fluoride
Combustibles
Ammonia

... And More

Over 20 different sensor options for Explosion Proof installations

calibration cycle, the output is driven to 1.5mA to inform downstream devices of the calibration in progress.

Three M1 models are available. The M1/LEL accepts catalytic bead combustible detectors; the M1/EC accepts low level electrochemical sensors and the M1/mA is wired to accept an external 4-20mA current loop input. Each Model M1 features a standard 4-20mA output and can accept option boards that include three 5A form C relays, MODBUS interface or isolated 4-20mA output.

Standard fault supervision circuitry continuously monitors the sensor output and drives the output to 0mA in the event of sensor failure or overrange.

A "Unity" control resets ZERO and SPAN settings to the middle of their range and clears any internal gain and offset settings. Diagnostic messages on the LCD indicate modes such as FAULT, CAL, DELAY and ESL (end of sensor life).

GDS Corp
Gas and Flame Detection

2513 Hwy 646
Santa Fe, Texas 77510
409-927-2980 • 409-927-4180 (fax)
www.gdscorp.com • info@gdscorp.com

Toxic & Combustible Gas Detection • Controllers • Process Monitors • Calibration Supplies

Model M1 SPECIFICATIONS	
Power Input	19-30VDC at less than three watts; 12VDC version available
Display	3 1/2 digit LCD displays engineering units, values and modes
Sensor Input	Accepts standard GDS Corp. toxic, oxygen or combustible sensors
Standard Output	Standard 3-wire 4-20mA current sink output. Max loop R is 750 ohms with nominal 24VDC power supply.
Optional Output #1	1500CMV isolated 4-20mA current source. Max loop R is 650 ohms with nominal 24VDC. Requires 4-wire interface
Optional Output #2	SPDT 5 A (resistive) High, Warn and Fault relays. Latching and failsafe modes available. Trip HI or Trip LO (for O ₂)
Optional Output #3	RS-485 MODBUS serial interface for multi-drop installations
Temp	-10°C to +60°C (see sensor limitations)
Housing	Instrument housing suitable for Class I, Groups B, C, D. Class 2, Groups E, F, G. Also meets NEMA 4 with "O" ring
Dimensions	Width 5.4" (137 mm), Height 8" (203 mm), Depth 5" (127 mm) Shipping weight 6.5 pounds (3 kg)
Approvals	CSA Certified C22.2 No. 152 for combustibles & ISA S82.02
Warranty	2 years from date of purchase on electronics and one year on sensors.

Model M1 Order Guide	
M1-AA XX-YYYY-Z-Q	
"AA"	M1-EC for sensor types 10-31 M1-LEL for sensor type 70 M1-I for sensor type 90
"XX"	SENSOR TYPE (see chart) ¹
"Y"	Suffix "YYYY" - Measurement Range. For example, 0-25 ppm would be "0025"
"Z"	Engineering Units 1 = Parts per million (ppm) 2 = Parts per billion (ppb) 3 = % lower explosive limit 4 = % by volume
"Q"	OUTPUT OPTIONS 0 = Standard 4-20mA output 1 = Alarm Relays 2 = MODBUS 3 = Isolated 4-20mA output

SENSOR TYPES					
10	Oxygen (0-25)	-30 to +55C	22	Ethylene Oxide (0-20)	-20 to +50C
11	Carbon Monoxide (0-300)	-30 to +50C	23	Arsine (0-1)	-20 to +40C
12	Chlorine (0-5) ¹	-20 to +50C	24	Silane (0-50)	-20 to +40C
13	Chlorine Dioxide (0-1) ¹	-20 to +40C	25	Fluorine (0-1)	-10 to +40C
14	Hydrogen (0-2000)	-20 to +50C	26	Phosgene (0-1)	-20 to +40C
15	Hydrogen Sulfide (0-100)	-30 to +50C	27	Hydrazine (0-1)	-10 to +40C
16	Hydrogen Cyanide (0-50)	-20 to +50C	28	Nitric Oxide (0-50)	-20 to +50C
17	Hydrogen Chloride (0-30) ¹	-20 to +50C	29	Nitrogen Dioxide (0-100)	-20 to +50C
18	Hydrogen Fluoride (0-10) ¹	-20 to +50C	30	Mercaptan TBM (0-15)	-10 to +40C
19	Sulfur Dioxide (0-25)	-30 to +50C	31	Tetrahydrothiophene (0-100)	-10 to +40C
20	Ammonia (0-100)	-20 to +40C	70	Catalytic Bead 0-100% LEL	-40 to +65C
21	Ozone (0-1)	-20 to +40C	90	4-20mA input	-40 to +60C

ALL DIMENSIONS IN INCHES

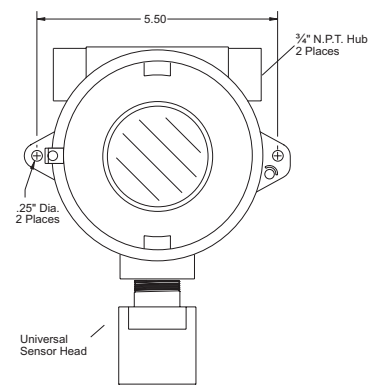
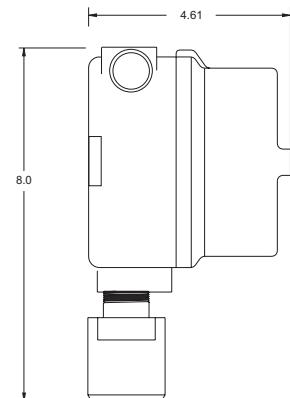

Gas and Flame Detection

2513 Hwy 646
Santa Fe, Texas 77510
409-927-2980 • 409-927-4180 (fax)
www.gdscorp.com • info@gdscorp.com

Toxic & Combustible Gas Detection • Controllers • Process Monitors • Calibration Supplies

NOTES

Note 1: Some highly reactive gases require Aluminum sensor head (M1 not XP with aluminum sensor head)