

GASMAX EC Gas Monitor

Loop-Powered Gas Monitor for Toxic Applications

- * Certified for Explosion Proof and Intrinsically Safe Installations
- * Non-polarized loop powered interface eliminates wiring errors
- * Graphic display shows values, units, trend graph, alarm levels
- * Three flashing Alarm LEDs with Programmable Alarm Levels
- * Real time clock tags alarm and calibration events
- * Supports both local and remote sensors for easy installation
- * Non-intrusive, prompted calibration with programmable cal gas
- * Power-up and post-calibration delays eliminate false alarms
- * Security settings to lock critical parameters
- * Auto-recognition of Smart Sensors uploads calibration data & more
- * Fault supervision circuitry detects failed sensor & transmits warning
- * Setup in hazardous area requires only simple magnetic wand
- * For combustible applications, see the GASMAX II gas monitor



The GASMAX EC single channel gas monitor for toxic or oxygen deficiency applications delivers the latest in loop-powered gas detection technology, reliability and ease of use.

Wide Variety of Available Sensors

The GASMAX EC support all GDS Corp toxic sensors, including oxygen, hydrogen sulfide, chlorine, carbon monoxide and more. In addition, GDS Corp Smart Sensors enhance this capability by maintaining their own record of serial number, born-on date, initial calibration values, engineering units and more. Using this information, the GASMAX EC constantly tracks sensor performance and calculates an estimate of sensor life remaining. Built-in fault detection circuitry constantly monitors the sensor for correct operation.

Advanced User Interface

The highly visible graphic display and flashing alarm LEDs constantly show

Hydrogen Sulfide
Oxygen Deficiency
Carbon Monoxide
Hydrogen Fluoride
Ammonia
Chlorine

... And More

Over 20 different sensor options for Explosion Proof and Intrinsically Safe Installations

alarm status, calibrated engineering values and a programmable tag name, plus a trend screen shows alarm levels and a graph of the most recent 30 minutes.

An internal real-time clock and event log time-stamp up to 300 calibration and alarm events for later review. Taking advantage of the high-resolution graphic display, an easy-to-use menu-driven operator interface using magnetic keys eliminates all analog potentiometers and allows complete setup and calibration without hazardous area declassification.

Three operational levels of security allow the GASMAX EC to be fully field configurable, partially restricted or completely restricted by way of user ID and access code.

Explosion-Proof or Intrinsically Safe

The GASMAX EC is CSA certified for use in Div 1 & Div 2 hazardous areas and can be installed as Explosion Proof (with stainless steel sensor head) or Intrinsically Safe (with aluminum sensor head) using appropriate wiring techniques and an Intrinsically Safe barrier. See notes on IS installation on back. An ATEX certified version for XP installations is also available.

GDS
Corp

Gas and Flame Detection

2513 Hwy 646

Santa Fe, Texas 77510

409-927-2980 • 409-927-4180 (fax)

www.gdscorp.com • info@gdscorp.com

GASMAX EC SPECIFICATIONS	
Power Input	10-30VDC at less than 0.75 watts in 2-wire 4-20mA configuration
Display	64 x 128 pixel LCD with 30-minute trend, bargraph and engineering units display.
Input	Accepts microamp-level signals from local or remote GDS Corp toxic or oxygen deficiency sensors
Calibration Range	Zero = +/- 15% of range with 0.1% resolution Span = Gain adjustment of 0.5 to 2.0 with 0.1% resolution
Accuracy	+/- 5% of full scale range (typical)
Standard Output	Standard 2-wire 4-20mA current sink output. Max loop R is 600 ohms with nominal 24VDC power supply.
Temp	-25°C to +60°C (see sensor limitations)
Housing	Aluminum housing with epoxy paint standard; #316 stainless steel optional
Dimensions	Width 5.4" (137 mm), Height 8" (203 mm), Depth 5" (127 mm) Shipping weight 6.5 pounds (3 kg)
Approvals	CSA Certified Div 1 & 2 Groups B, C, D. Suitable for explosion-proof installations CSA Certified Div 1 & 2 Groups A, B, C, D. Intrinsically safe. IMPORTANT: Intrinsically Safe installations require IS barrier #10-0263 (MTL 7787P+) or equivalent. ATEX Certified EX II 2 G EEx d IIB + H2 T5
Warranty	Two years on electronics and one year on sensors from date of purchase

SENSOR TYPES					
10	Oxygen (0-25%)	-30 to +55C	21	Ozone (0-1) ⁶	-20 to +40C
11	Carbon Monoxide (0-300)	-30 to +50C	22	Ethylene Oxide (0-20)	-20 to +50C
12	Chlorine (0-5) ⁶	-20 to +50C	23	Arsine (0-1)	-20 to +40C
13	Chlorine Dioxide (0-1) ⁶	-20 to +40C	24	Silane (0-50)	-20 to +40C
14	Hydrogen (0-2000)	-20 to +50C	25	Fluorine (0-1)	-10 to +40C
15	Hydrogen Sulfide (0-100)	-30 to +50C	26	Phosgene (0-1)	-20 to +40C
16	Hydrogen Cyanide (0-50)	-20 to +50C	27	Hydrazine (0-1)	-10 to +40C
17	Hydrogen Chloride (0-30) ⁶	-20 to +50C	28	Nitric Oxide (0-50)	-20 to +50C
18	Hydrogen Fluoride (0-10) ⁶	-20 to +50C	29	Nitrogen Dioxide (0-100)	-20 to +50C
19	Sulfur Dioxide (0-25)	-30 to +50C	30	Mercaptan TBM (0-15)	-10 to +40C
20	Ammonia (0-100) ⁶	-20 to +40C	31	Tetrahydrothiophene (0-100)	-10 to +40C

Intrinsically Safe Installations

Certain highly reactive gases (see Note 6 above) require aluminum sensor heads and Intrinsically Safe (IS) installation in hazardous locations. Intrinsically Safe equipment is defined as "equipment which is incapable of releasing sufficient electrical or thermal energy under normal or abnormal conditions to cause ignition of a specific hazardous atmospheric mixture in its most easily ignited concentration." IS installations require an IS barrier (#10-0263 MTL 7787P+) or equivalent that must be mounted in an area designated as Non-hazardous.



2513 Hwy 646
Santa Fe, Texas 77510
409-927-2980 • 409-927-4180 (fax)
www.gdscorp.com • info@gdscorp.com

GASMAX EC Order Guide	
GM EC A - B - C [ATEX] [SS]	
"A"	SENSOR HEAD ^{1,2,6} 1 = Stainless Steel Sensor Head 2 = Stainless Steel Sensor Head w/ Splash Guard 3 = Aluminum Sensor Head (IS) 4 = Aluminum Sensor Head (IS) w/ Splash Guard 5 = Remote Stainless Steel Sensor Head 6 = Remote Stainless Steel Sensor Head w/ Splash Guard 7 = Remote Aluminum Sensor Head (IS) 8 = Remote AL Sensor Head (IS) w/ Splash Guard 12 = Stainless Steel Sensor Head for ATEX certification
"B"	SENSOR TYPE (see chart) ⁵
"C"	DETECTION RANGE ⁵ 1 = 0 - 1 2 = 0 - 5 3 = 0 - 10 4 = 0 - 25 5 = 0 - 50 6 = 0 - 100 7 = 0 - 500 8 = 0 - 1000 Custom RXXXX (0-9999)

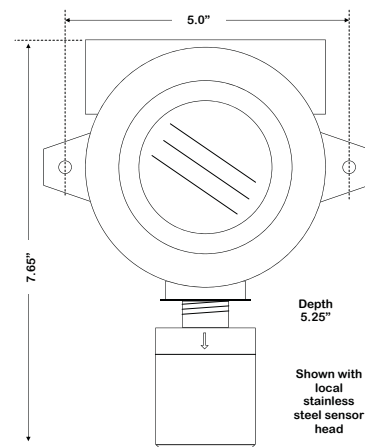

NOTES
Note 1: Remote sensor installations do not utilize Smart Sensor interface
Note 2: Maximum distance for remote e-chem sensor connection is 25ft (3m).
Note 5: Standard ranges shown; contact factory for additional ranges
Note 6: Some highly reactive gases require Aluminum sensor head & IS installation for XP