

# C1 Protector Alarm Controller

## Eight or Sixteen Channel Alarm & Display Controller for Critical Monitoring Applications

- \* 8/16 channels of analog, digital, wireless or bridge-type input
- \* Large LCD display shows values, bar-graph and 24 hr trend data
- \* Built-in support for GASMAX wireless gas monitors
- \* Individual alarm LEDs for each channel and alarm (total of 48)
- \* Standard 5A SPDT common relays for HORN, A2, A1 & FAULT
- \* Up to 48 discrete relays for easy interface to existing circuitry
- \* Relay voting logic reduces need for external hardware
- \* One or two optional 8-channel 4-20mA analog outputs
- \* ACK button silences HORN without affecting alarm relays
- \* Pushbutton zero and span calibration for directly connected sensors
- \* Operates on 10-30VDC or 110/220V 50/60 Hz AC
- \* MODBUS® master and slave ports for maximum flexibility
- \* CSA C22.2 No. 1010.1 & 152 for combustibles & ISA S82.02; UL 1604 / C22.2 No 213 (Div 2 Groups A, B, C, D); EN55011 & EN61000 (CE Mark).



Available in panel mount, rack mount (2x), NEMA 4X fiberglass or stainless steel or NEMA 7 explosion proof enclosures

The C1 Protector Controller is an ideal solution for monitoring up to 16 critical input variables.

### Flexibility

Built around 'plug and play' input and output modules, the C1 Protector controller can accept signals from wireless monitors, analog sensors, digital sensors, discrete inputs or even direct connection to bridge-style combustible or VOC sensors. Built-in calibration mode, three programmable alarm levels per channel and four common relays (A1, A2, FAULT and HORN) are included in the base configuration. Up to sixteen 4-20mA analog outputs, 48 discrete relays and an Ethernet interface are available as options.

### Status "At A Glance"

The high resolution graphic LCD displays data as trends, bargraphs and calibrated engineering units; a 24-hour trend graph for each channel is always available. Forty-eight high intensity LEDs show channel status in real-time. In addition to

touch-sensitive buttons, a standard magnetic keypad allows non-intrusive operation in potentially hazardous locations.

### Digitally Connected, Wireless Enabled

The C1 Protector controller includes both master and slave RS-485 serial MODBUS interfaces for maximum flexibility. The C1's master port reads data from remote RS-485 serial or wireless sensors, while the slave port enables remote MODBUS masters to access the C1's channel and configuration data in real time. Built-in support for GDS Corp GASMAX wireless gas monitors makes it easy to install and manage a wireless system. Using GDS Corp's ProtectorView software and MODBUS / TCP interface, a remote display of the controller's real-time status and stored configuration is available across any Ethernet network.

### Reliability

The C1 Protector is designed from the ground up for critical alarm monitoring and is CSA certified for use in Class I Division 2 hazardous areas. In addition to gas detection, the C1 Protector controller is widely used in flow measurement, tank level monitoring and other critical alarm applications. The C1 Protector is available in panel mount, single or dual rack mount, NEMA 4X fiberglass and stainless steel, and NEMA 7 explosion proof enclosures.

**GDS**  
**Corp**

Gas and Flame Detection

2513 Hwy 646

Santa Fe, Texas 77510

409-927-2980 • 409-927-4180 (fax)

www.gdscorp.com • info@gdscorp.com

<b>C1 Protector SPECIFICATIONS</b>	
<b>Power Input</b>	10-30VDC or 110/220 V 50/60Hz AC; 150W AC power supply included; 12 Watts MAX for electronics
<b>Display</b>	Backlit 240x128 pixel LCD shows trend, bargraph and engineering units; 52 discrete LEDs show channel status in real time
<b>Wireless Input</b>	Up to 16 remote GASMAX wireless gas monitors. Select option "M" or add external radio module. (MODBUS master port disabled when using wireless)
<b>Analog Input</b>	Optional 8 or 16 4-20mA source into 100 ohms; includes excitation for easy connection to 2 or 3 wire transmitters
<b>MODBUS I/O</b> <sup>1</sup>	MODBUS master RS-485 half or full duplex port capable of reading remote GASMAX sensors, other compatible slave devices or wireless MODBUS slave RS-485 half or full duplex port capable of being read by remote MODBUS master device
<b>Relay Output</b>	Standard common output relays: A1, A2, FAIL & HORN; SPDT rated 5A@ 30DC/240AC Optional auxiliary relay board with secondary A1, A2 and HORN; SPDT rated 5A Optional 8 channel discrete relay board (up to 6x)
<b>Analog Output</b>	Optional 8 or 16 channel 4-20mA output (10 bit D/A). Max loop R is 800 ohms with nominal 24VDC supply
<b>Digital Output</b>	Optional printer output or MODBUS / TCP interface
<b>Temp</b>	-25°C to +65°C
<b>Mounting</b>	Panel mount for 19" rack; NEMA 4X wall-mount suitable for Class 1 Div 2 Groups B, C, D; NEMA 7 wall-mount suitable for Class 1 Div 1 Groups B, C, D
<b>Dimensions</b>	NEMA 4X fiberglass: Width 13" (330 mm); Height 16" (406 mm); Depth 8.63" (220 mm) Panel Mount: 5.25" x 9.20" cutout
<b>Approvals</b>	CSA C22.2 No. 1010.1 & 152 for combustibles & ISA S82.02; UL 1604 / C22.2 No 213 (Div 2 Groups A, B, C, D); EN55011 & EN61000 (CE Mark).
<b>Warranty</b>	2 years from date of purchase

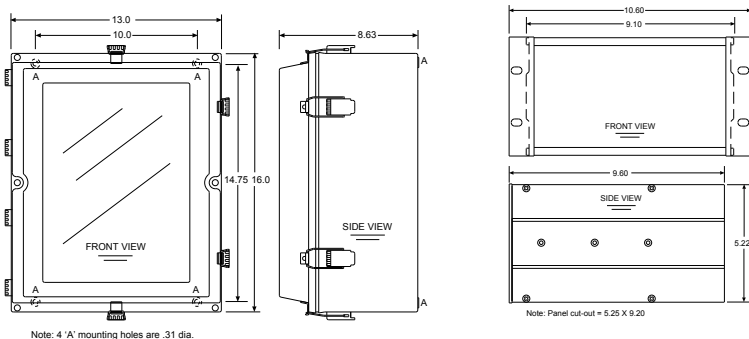

NEMA 4X Fiberglass

Panel Mount



2513 Hwy 646  
 Santa Fe, Texas 77510  
 409-927-2980 • 409-927-4180 (fax)  
 www.gdscorp.com • info@gdscorp.com

<b>C1 Protector Order Guide</b>	
<b>C1 / A / B - C / D - E - F - G - H / J - K - L - M</b>	
<b>"A"</b>	PM = Panel / rack mount for 19" rack N4 = NEMA 4X wall-mount for Class I Div 2 Groups B, C, D SS = NEMA 4 stainless steel for Class I Div 2 Groups B, C, D XP = NEMA 7 wall-mount for Class I Div 2 Groups B, C, D
<b>"B"</b> <b>&amp;</b> <b>"C"</b>	00 = MODBUS or WIRELESS input 10 = 8 channel analog input 21 = 2 channels of bridge sensor input 22 = 4 channels of bridge sensor input 23 = 6 channels of bridge sensor input 24 = 8 channels of bridge sensor input
<b>"D"</b>	0 = Built-in 4x 5A SPDT alarm relays 1 = Add one aux common relay board with additional 3x 5A SPDT relays
<b>"E"</b>	1 = Add one 8-channel analog output 2 = Add two 8-channel analog output
<b>"F"</b>	1 - 6 = Add up to six 8-channel relay output boards
<b>"G"</b>	1 = Add one parallel printer interface 2 = Add MODBUS / TCP interface
<b>"H"</b>	1 = Add 100db alarm (NEMA 4x)
<b>"J"</b>	1 = Add expansion plate for NEMA 4X for 4 additional option locations 2 = Add expansion plate for NEMA 7 for three additional option locations
<b>"K"</b>	1 = Add one NEMA 4X wall mount enclosure for eight additional options
<b>"L"</b>	0 = Standard alarm ACK on controller 1 = Local alarm acknowledge button on exterior of NEMA 4X 2 = Remote alarm acknowledge button in XP junction box
<b>"M"</b>	0 = None <sup>1</sup> 1 = 900Mhz internal wireless radio 2 = 2.4GHz internal wireless radio 3 = 900Mhz external wireless radio 4 = 2.4Ghz external wireless radio

**NOTES**

Note 1: Wireless modem replaces MODBUS master channel interface (wireless & MODBUS master cannot operate simultaneously)

Note 2: Maximum distance for remote e-chem sensor connection is 25ft (3m).